

Stimulated emission in multiple-photon-pumped xenon and argon excimers*

S. E. Harris, A. H. Kung, E. A. Stappaerts, and J. F. Young

Microwave Laboratory, Stanford University, Stanford, California 94305
(Received 14 May 1973)

Multiple photon absorption of laser radiation at 2660 and 3547 Å is used to pump excimers of Xe and Ar. Line narrowing is observed in bands ~ 100 Å wide, centered at 1730 and 1260 Å, respectively.

Basov has suggested that stimulated emission in the vacuum ultraviolet (VUV) might be produced by utilizing the continuum emission of rare-gas liquids and solids excited by high-power electron beams.¹ He and co-workers reported VUV stimulated emission in electron-beam-pumped liquid xenon.² More recently, Koehler *et al.*³ and Hoff *et al.*⁴ reported laser action in high-pressure Xe gas pumped by an electron beam.

In this letter, we report stimulated emission of xenon and argon excimers pumped by multiphoton absorption of laser radiation at 3547 and 2660 Å. Typically, about 25% of the incident pumping radiation is absorbed and effective in producing excimer fluorescence. The fluorescent emission of the xenon and argon excimers centers at 1730 and 1260 Å, and has half-power line-widths of about 140 and 105 Å, respectively. Line narrowing, and thus stimulated emission, are observed for 2660-Å-pumped xenon and argon, though 3547-Å-pumped xenon, while yielding comparable excimer fluorescence, does not show stimulated emission.

A schematic of the experimental apparatus is shown in Fig. 1. A mode-locked Nd:YAG laser, followed by a single-pulse selecting switch and amplifier, produced 1.064- μm pulses with a width of about 25 psec and a peak power of about 1×10^8 W. Two KDP crystals were used to convert this radiation to 3547 or 2660 Å. A peak power of about 1×10^7 W was available at either of these frequencies. A gas cell in which the gas pressure could

be varied between 0 and 20 atm was attached to a normal-incidence 1-m McPherson monochromator. The incident laser beam was focused into the center of this cell to an area of about 1.4×10^{-6} cm², and thus to a power density of about 7×10^{12} W/cm². The confocal parameter of the focus and thus the length of the pumped region were about 1.9 mm. The fluorescent emission was detected by an EMR CsI solar blind photomultiplier. Four cases—2660-Å-pumped argon, 2660-Å-pumped xenon, 3547-Å-pumped xenon, and 3547-Å-pumped argon—were examined. To establish line narrowing, a comparison of fluorescence collinear with the incident laser beam to fluorescence off axis with this beam was made.

Figures 2(a)–2(c) show collinear fluorescence and off-axis fluorescence for the first three of the above cases. Line narrowing (and some structure) is apparent for 2660-Å-pumped argon and xenon, while line narrowing does not occur for 3547-Å-pumped xenon. Though the percentage of line narrowing is not large (20% at the maximum), the results are consistently reproducible to within 4%. Absorption of the incident laser beam was 20%, 50%, and 55%, respectively, for these three cases. An estimated quantum efficiency from absorbed laser power to total excimer fluorescence of between 30% and 50% was obtained. The signal from 3547-Å-pumped argon was weak, and it was not possible to make a meaningful comparison of on- and off-axis fluorescence.

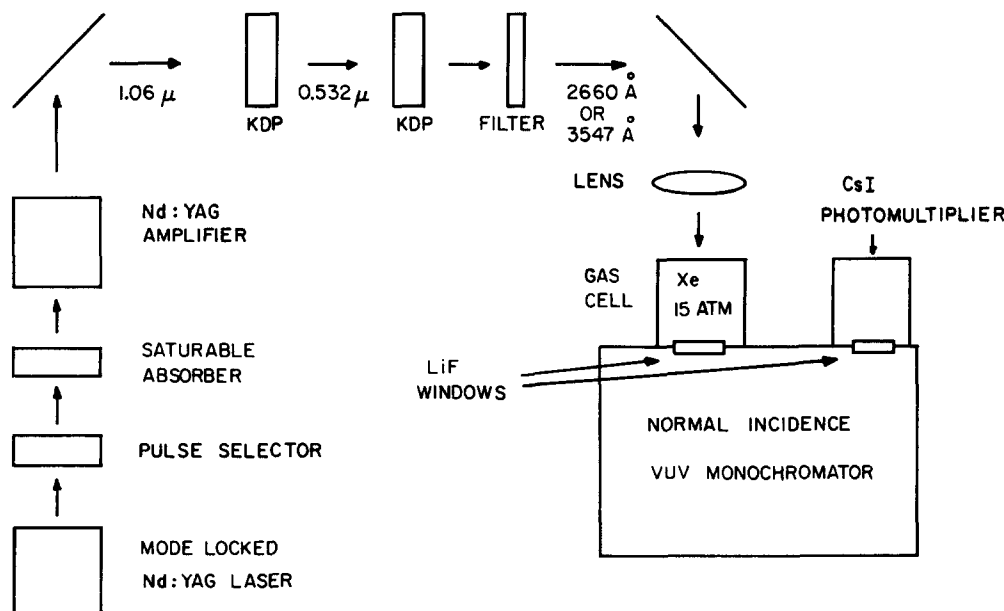

FIG. 1. Schematic of experimental apparatus.

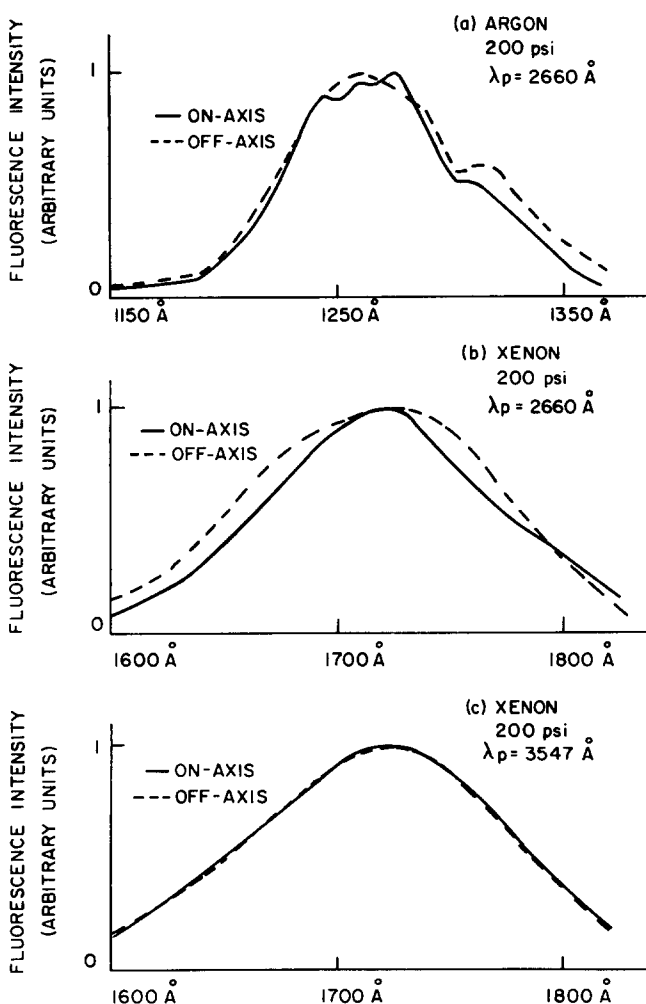

FIG. 2. On-axis and off-axis fluorescence from optically pumped xenon and argon excimers.

Figure 3 shows the fractional line narrowing of the collinear fluorescence as a function of the pressure of the inert gas. Normalization is to the linewidth of the off-axis fluorescence, which, as expected, is independent of pressure in the range of interest. For both 2660-Å-pumped xenon and argon, maximum line narrowing occurs in the vicinity of 200 psi, probably indicating a reduction in gain due to excimer-excimer deexcitation.⁵ It is of interest to note that the maximum line narrowing for 2660-Å-pumped xenon occurs at 200 psi, which is very close to the optimum pressure which Hoff *et al.*⁴ report for electron-beam-pumped xenon.

The failure to obtain line narrowing for 3547-Å-pumped xenon is difficult to explain. The total excimer fluorescence for this case had approximately the same magnitude as in the 2660-Å-pumped xenon, and differed only in that it centered about 10 Å toward longer wavelengths. This small shift in center wavelength and the failure to obtain line narrowing indicates that this fluorescence originates from the $^3\Sigma_u^+$ level as opposed to the $^1\Sigma_u^+$ level excited by 2660-Å radiation. The spontaneous lifetime of the $^1\Sigma_u^+$ level is believed to be several nanoseconds, while that for the $^3\Sigma_u^+$ level is several microseconds.⁵ The stimulated emission cross section for the $^3\Sigma_u^+$ level is thus much smaller than that for the $^1\Sigma_u^+$

level and is not expected to lead to line narrowing and gain. It is still very surprising to us that multiple-photon pumping to levels so high in the energy level structure of the xenon excimer should yield such a selective pumping mechanism.

Beside for the usual multiphoton absorption process where an intense electromagnetic wave causes a single atom to absorb several photons, there is a second and often stronger type of multiphoton process which must be considered. This is a cooperative process where the electromagnetic wave causes the generation of third-harmonic radiation which is immediately absorbed. Our calculations, in part based on previous experimental work,⁶ show that in 3547-Å-pumped xenon this latter process, i. e., third-harmonic generation and absorption, is about 40 times more effective than the more usual direct three-photon absorption process. For 2660-Å-pumped xenon, optical absorption varied as input power square, indicating a two-photon absorption process to xenon excimer levels in the vicinity of 1330 Å. Absorption of 3547-Å radiation was proportional to the cube of the input power and thus implies excitation of excimer levels in the vicinity of 1182 Å. Further experiments will be necessary to definitely establish the nature of the absorption process and the extent to which different xenon excimer levels are excited.

Due to distributed loss caused by either ground-state xenon atoms or photoionization loss of excited excimers,⁷ the directional line narrowing demonstrated in these experiments cannot be used to establish net gain.⁸ If we assume the absence of any such distributed loss, then the observed line narrowing of the 2660-Å-pumped xenon and argon implies single-pass power gains of 2.8 and 4 dB, respectively. At the optical power densities employed in these experiments, the excited excimer density exceeds that in the electron-beam-pumped experiments of Koehler *et al.*³ and Hoff *et al.*⁴ With appropriate resonators of other feedback techniques, it is thus likely that multiple-photon optical pumping can substitute for electron beam pumping in the construction of excimer lasers. When further developed, the technique of multiple-photon pumping of excimer systems should also be useful in sorting out excimer formation paths, and for measuring spontaneous decay times and excimer collision rates. It may

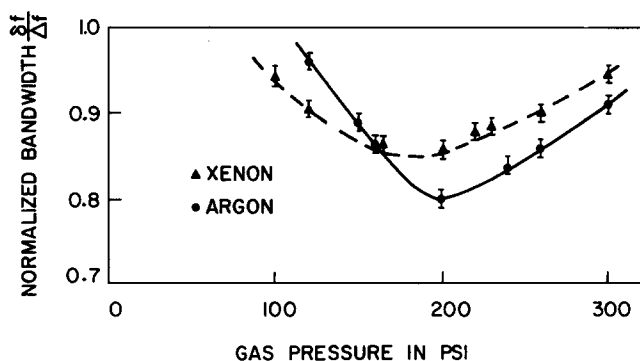

FIG. 3. Normalized emission linewidth vs gas pressure of on-axis excimer fluorescence.

also allow the construction of practical tunable VUV laser systems.

The authors gratefully acknowledge a number of helpful discussions with J. Aldridge, G. Bjorklund, R. M. Hill, D. C. Lorents, P. W. Hoff, C. K. Rhodes, and A. E. Siegman.

*Work jointly supported by the Air Force Cambridge Research Laboratories, by the United States Atomic Energy Commission, by NASA, and by the Office of Naval Research.

¹N. G. Basov, *IEEE J. Quantum Electron.* **QE-2**, 354 (1966).

²N. G. Basov, O. V. Bogdankevich, V. A. Danilychev, A. G. Devyatkov, G. N. Kashnikov, and N. P. Lantsov, *Sov. Phys.-JETP* **7**, 317 (1968); N. G. Basov, V. A. Danilychev, and Yu. M. Popov, *Sov. J. Quantum Electron.* **1**, 18 (1971).

³H. A. Koehler, L. J. Ferderber, D. L. Redhead, and P. J. Ebert, *Appl. Phys. Lett.* **21**, 198 (1972).

⁴P. W. Hoff, J. C. Swingle, and C. K. Rhodes, *Opt. Commun.* (to be published).

⁵C. K. Rhodes (private communication).

⁶A. H. Kung, J. F. Young, and S. E. Harris, *Appl. Phys. Lett.* **22**, 301 (1973).

⁷D. C. Lorents and R. E. Olson (unpublished).

⁸A. Yariv and R. C. C. Leite, *J. Appl. Phys.* **34**, 3410 (1963).