

An Integrated Color Pixel in 0.18 μ m CMOS technology

Peter Catrysse, Brian Wandell and Abbas El Gamal

Information Systems Laboratory
Department of Electrical Engineering
Stanford University
Stanford, CA 94305, USA

Abstract

A method for controlling photodetector wavelength responsivity via metal layer patterns is demonstrated in a standard 0.18 μ m CMOS technology. Responsivities suitable for RGB integrated color pixels, peaking at 450nm, 575nm and 750nm, are measured. Over 100% uncovered area transmittances are measured. We discuss possible theoretical explanations for the observed high transmittance.

Introduction

In the field of microwave engineering, regular metal grids have been used for a long time as filters, transmitting some wavelengths and blocking others [1]. More recently, due to continued advances in IC manufacturing technology, metal grids with periodicity commensurate with the wavelength of near-infrared light have been demonstrated [2]. Such grids act as filters in the infrared wavelength regime. In this paper, we demonstrate visible wavelength selectivity using sub-visible wavelength metal grids fabricated in a standard 0.18 μ m CMOS technology. Furthermore, we explore the use of such metal grids in the design of an integrated color pixel (ICP) in which a 1D or 2D metal pattern, using already available metal layers, is deposited on top of the photodetector in a CMOS or CCD image sensor pixel. The results demonstrate transmittance and responsivities potentially suitable for color imaging. By controlling wavelength responsivity in the pixel design process, these ICPs may eliminate the need for color filter arrays.

ICP Test Structures

To demonstrate the visible wavelength selectivity of metal patterns and to investigate their use for color imaging, we designed and implemented ICP test structures in a standard 0.18 μ m CMOS technology. In this technology, it is possible to create sub-visible wavelength features on metal layers, e.g., metal wire width and spacing finer than 270 nm. We implemented test structures comprising 6 and 12 μ m ICPs with n+/pwell photodiodes. An ICP circuit schematic is shown in Fig. 1. A standard 3-transistor Active Pixel Sensor (APS) circuit, directly connected to a chip output via a follower amplifier, was used. To reduce transistor gate leakage and to increase voltage swing, we used 3.3V thick-oxide transistors. The circuit operation of the ICP is

otherwise standard and will not be described here. The ICP layout is shown in Fig. 2 and 3. Several 1D and 2D metal patterns with periodicity ranging from $a=540$ nm to 810nm and spacing from $d=270$ nm to 540nm and using different metal layers were deposited on top of APS photodetectors. A photomicrograph of the chip with the ICP test structures is shown in Fig. 4.

Experimental Results

Measured 2D metal-1 patterned ICP spectral responsivities normalized with respect to peak photodiode response are shown in Fig. 5 (a). Note that the measured responsivities of 0.05, 0.15, and 0.25 are only 50% lower than the respective fractions of uncovered photodiode areas even though hole sizes are smaller or equal to the wavelength. Fig. 5 (b) shows the responsivities after applying a linear transformation using an appropriate 3X3 matrix. The transformed responsivities clearly demonstrate that the 2D metal-1 patterned ICPs exhibit RGB color pixel behavior peaking at 450nm, 575nm and 750nm.

Measured transmittances of 1D metal-1 patterned ICP are shown in Fig. 6. Note that the transmittances in the visible wavelength range are around 0.50, which is slightly higher than the 0.47 fraction of uncovered photodiode area, i.e., hole transmittance greater than 100% was observed. Furthermore, observe that these high transmittance 1D metal-1 patterns exhibit significant wavelength selectivity in the near-infrared wavelength range as well.

The results demonstrate that placing metal-1 patterns on top of a photodetector can significantly influence its spectral responsivity. Further, the measurements in Figure 4 show that with additional signal processing one can obtain responsivities that are suitable for color imaging. The metal patterns we implemented do not constitute a viable alternative to color filter arrays, however. The 1D metal-1 patterns had high transmittance but no selectivity in the visible wavelength range, while the 2D metal-1 patterns had high selectivity but low transmittance. In more advanced processes with finer metal width, spacing, and thickness, patterns with both high transmittance and visible wavelength selectivity become possible, making ICPs viable.

Discussion

It is possible to accurately determine the wavelength responsivity and transmittance for the 1D or 2D metal-1 patterned ICPs by numerically solving Maxwell's equations. However, to optimize the design of ICPs, it is preferable to have a physical theory involving a few key parameters, e.g., pattern material and periodicity that summarize the physical mechanisms that control wavelength transmission. Unfortunately, for the wavelengths and pattern characteristics we are investigating, there does not appear to be a unified phenomenological theory. For example, Popov wrote about grating properties, "almost nothing exists that has not been classified as an anomaly (Ref. [3], p. 142)".

The natural starting point for such a theory is scalar diffraction theory. This theory, however, is only applicable when pattern dimensions are significantly larger than the wavelength of the incident light [4]. The desired patterns of an ICP are smaller than the wavelength and thus require a vectorial generalization of diffraction theory [5]. Such a theory must also incorporate properties of the pattern material, e.g., complex refractive index. Under certain simplifying assumptions, such as infinitesimally thin and perfectly conducting metal layers, it is possible to find closed form or asymptotically converging series solutions to transmittance of electromagnetic radiation by periodic arrays of holes [6],[7]. Some of these simplified theories do predict greater-than-100% transmittance, as we have observed for 1D metal-1 patterned ICPs [8]. Extending these theories to more realistic pattern dimensions and metal properties requires the use of numerical electromagnetic methods [9],[10]. To calculate the spectral transmittance for highly conducting 1D metal patterns, a modal formulation seems possible (Ref. [5], Ch. 1). Lochbihler *et al.* describes a procedure to adapt the rigorous modal method to be applicable in the visible wavelength regime where the assumption of a perfect conductor does not hold [10]. For 2D metal patterns, a modal approach is possible for perfect conductors but does not lend itself to an extension for finitely conducting metal [1]. A Fourier-expansion modal method for crossed-gratings is required (Ref. [5], Ch. 7).

It is also possible that surface plasmon resonance contributes to the high transmittance of the 1D metal-1 patterns. Recent experiments [11] have shown that a periodic array of sub-wavelength holes in an optically thick metallic film exhibits extraordinary optical transmittance up to several orders of magnitude higher than small-hole diffraction theory predicts [6]. The zero-order transmission spectra reported are characterized by well-defined transmission maxima at wavelengths up to ten times that of the hole diameter with efficiencies exceeding unity. These spectra depend on both the spatial arrangement of the holes in the film and the type of metal used to fabricate the film. Providing the appropriate metal pattern enables an incident optical wave to stimulate a collective oscillation of electrons on the front metal surface

(surface plasmons). The front surface plasmons subsequently couple with the back surface plasmons through the holes in the metal. At the back surface, the reverse momentum transfer process results in the emission of photons. The resonant wavelength for such a surface plasmon induced transmission depends on the type of metal, the surrounding dielectric, and the geometry of the pattern. Calculation of the range of possible surface plasmon resonance wavelengths for 1D metal patterns used in our 0.18 μm technology test structures gives a lower bound on the wavelength of 600nm, which is within the visible range.

Summary

We demonstrated high transmittance and responsivities of metal patterned ICPs in a standard 0.18 μm CMOS technology. The proposed ICP approach may eventually provide a more flexible and lower cost alternative to color filter arrays commonly used on image sensors. We discuss possible theoretical explanations for the observed high transmittance. Below 600nm, such high transmittance can be explained by vectorial diffraction theory, while above 600nm surface plasmon resonances may be present.

This work is supported by the Programmable Digital Camera Project and Philips. The authors especially thank B. Fowler and M. Godfrey for their assistance with the ICP implementation. P. Catrysse is "Aspirant" with F.W.O.-Vlaanderen (Belgium).

References

- [1] P. J. Bliiek, L. C. Botten, R. Deleuil, R. C. McPhedran, and D. Maystre, "Inductive grids in the region of diffraction anomalies: theory, experiments and applications," *IEEE Trans. Microwave Theory Tech.*, vol. 28, pp. 1119-1125, 1980.
- [2] H. Tamada, T. Doumuki, T. Yamaguchi, and S. Matsumoto, "Al wire-grid polarizer using the s-polarization resonance effect at the 0.8- μm -wavelength band," *Opt. Lett.*, vol. 22, pp. 419-421, 1997.
- [3] E. Popov, "Light diffraction by relief gratings: a macroscopic and microscopic view," in *Progress in Optics*, vol. 31, E. Wolf, Ed. Amsterdam: North-Holland, 1993, pp. 140-187.
- [4] J. W. Goodman, *Introduction to Fourier Optics*. San-Francisco: McGraw-Hill, 1968.
- [5] R. Petit, *Electromagnetic Theory of Gratings*, vol. 22. Berlin: Springer-Verlag, 1980.
- [6] H. A. Bethe, "Theory of Diffraction by Small Holes," *Phys. Rev.*, vol. 66, pp. 163-182, 1944.
- [7] C. J. Bouwkamp, "On Bethe's theory of diffraction by small holes," *Philips Res. Rep.*, vol. 5, pp. 321-332, 1950.
- [8] W. Andrejewski, "Die beugung elektromagnetischer Wellen an der leitenden Kreisscheibe und an der kreisförmigen Öffnung imleitenden ebenen Schirm," *Z. Angew. Phys.*, vol. 5, pp. 178-186, 1953.
- [9] A. Roberts, "Electromagnetic theory of diffraction by a circular aperture in a thick, perfectly conducting screen," *J. Opt. Soc. Am. A*, vol. 4, pp. 1970-1983, 1987.
- [10] H. Lochbihler and R. Depine, "Highly conducting wire gratings in the resonance region," *Appl. Opt.*, vol. 32, pp. 3459-3465, 1993.
- [11] T. W. Ebbesen, "Extraordinary optical transmission through sub-wavelength hole arrays," *Nature (London)*, vol. 391, pp. 667-669, 1998.

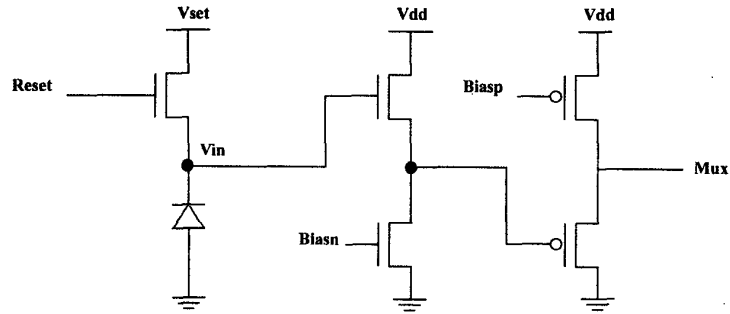

Figure 1: ICP circuit consisting of an APS pixel and a two-stage follower amplifier.

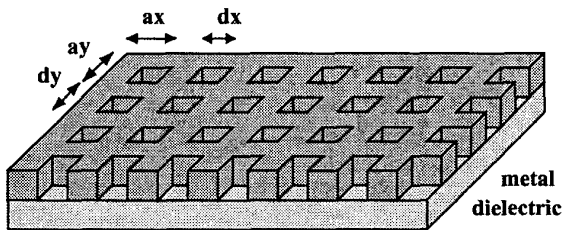
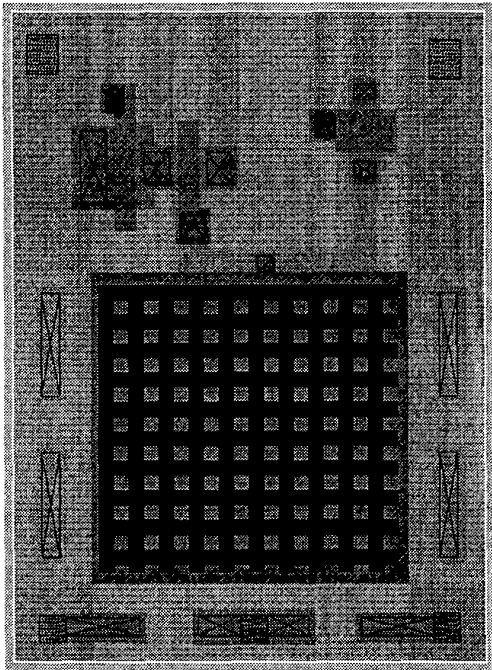

Figure 2: ICP layout with 2D metal pattern with period a_x , a_y and hole size d_x , d_y .

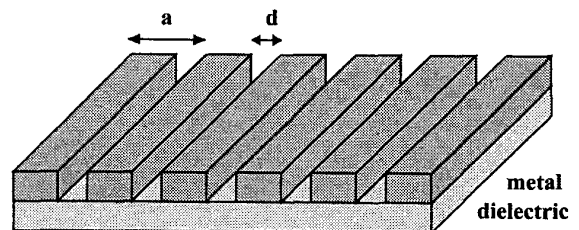
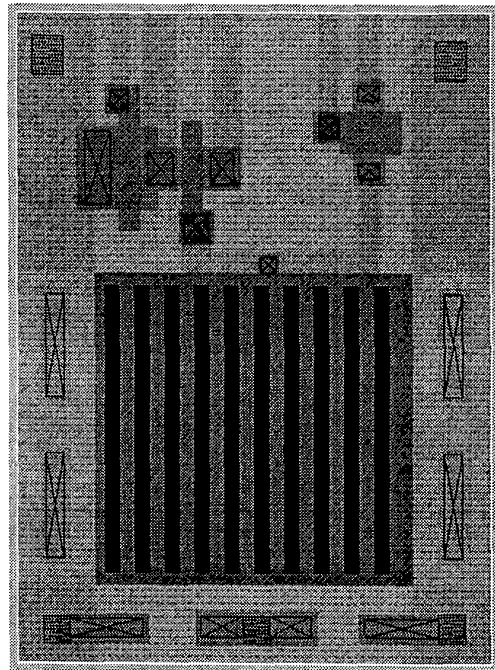

Figure 3: ICP layout with 1D metal pattern with period a and hole size d .

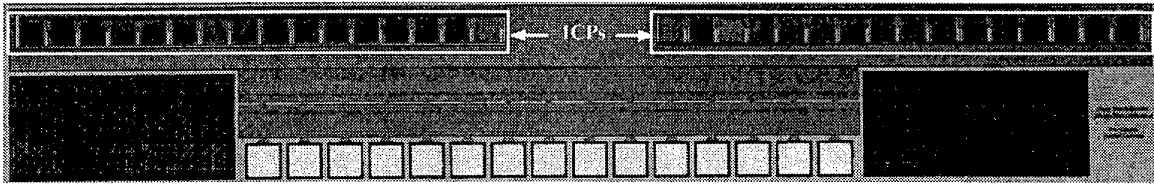
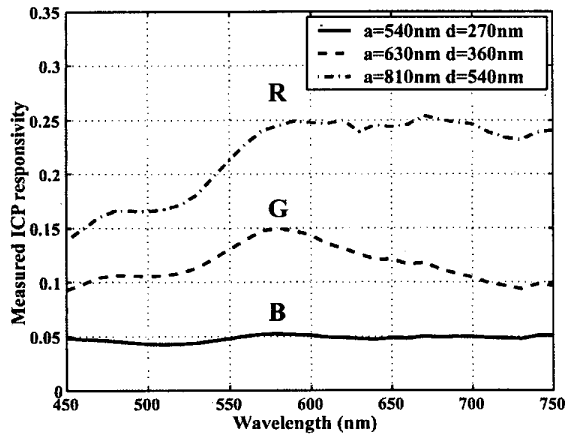
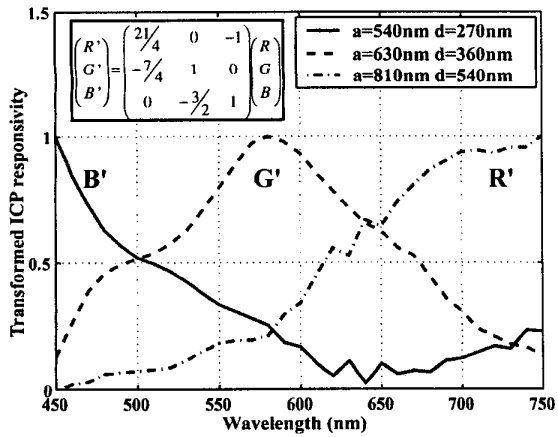

Figure 4: Photomicrograph of ICP test structures in 0.18μm CMOS technology.



(a)



(b)

Figure 5: (a) Measured 2D metal-1 patterned ICP spectral responsivities normalized with respect to peak photodiode response. (b) Transformed and normalized 2D metal-1 patterned ICP spectral responsivities.

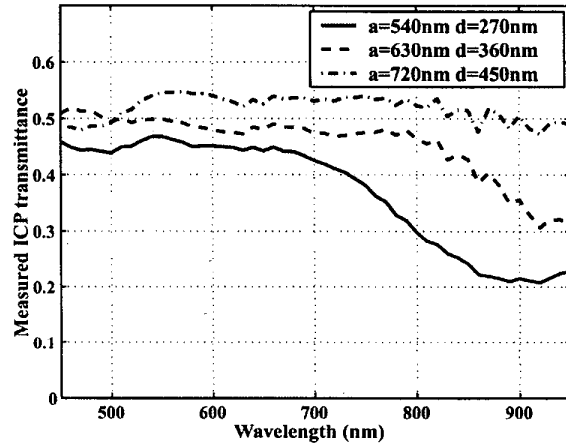

Figure 6: Measured 1D metal-1 patterned ICP transmittances.