



Graph Mining: Laws, Generators and Tools

Christos Faloutsos

CMU



Thanks

- Michael Mahoney
- Lek-Heng Lim
- Petros Drineas
- Gunnar Carlsson





Outline

- **Problem definition / Motivation**
- Static & dynamic laws; generators
- Tools: CenterPiece graphs; Tensors
- Other projects (Virus propagation, e-bay fraud detection)
- Conclusions



Motivation

Data mining: ~ find patterns (rules, outliers)

- Problem#1: How do real graphs look like?
- Problem#2: How do they evolve?
- Problem#3: How to generate realistic graphs

TOOLS

- Problem#4: Who is the ‘master-mind’?
- Problem#5: Track communities over time



Problem#1: Joint work with

Dr. Deepayan Chakrabarti
(CMU/Yahoo R.L.)





Graphs - why should we care?

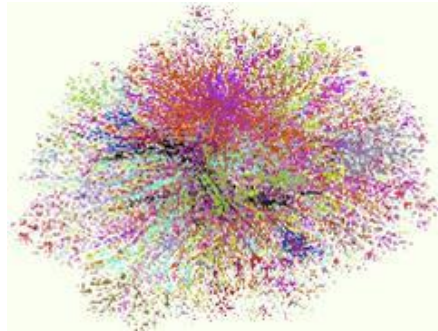

Internet Map
[lumeta.com]

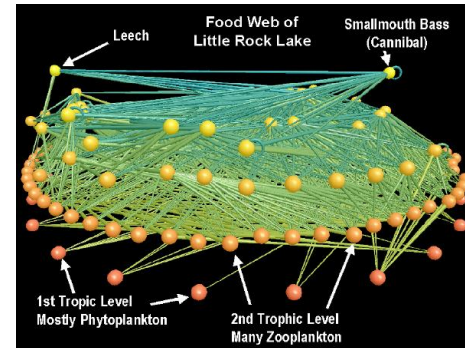

Food Web
[Martinez '91]

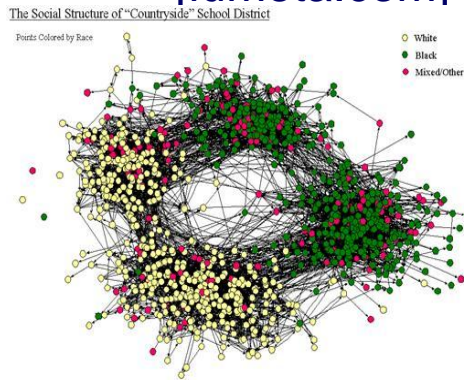

Friendship Network
[Moody '01]

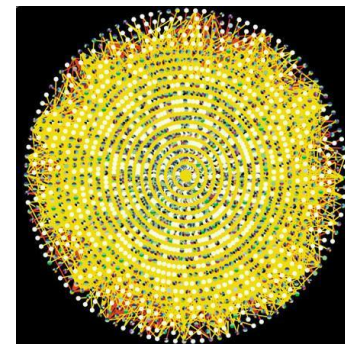

Protein Interactions
[genomebiology.com]



Graphs - why should we care?

- IR: bi-partite graphs (doc-terms)

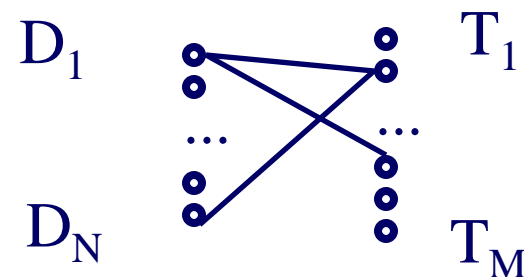

- web: hyper-text graph

- ... and more:



Graphs - why should we care?

- network of companies & board-of-directors members
- ‘viral’ marketing
- web-log (‘blog’) news propagation
- computer network security: email/IP traffic and anomaly detection
-



Problem #1 - network and graph mining

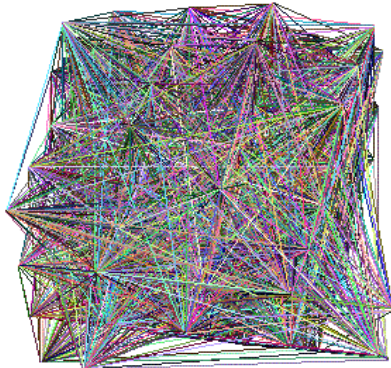

- How does the Internet look like?
- How does the web look like?
- What is ‘normal’/‘abnormal’?
- which patterns/laws hold?



Graph mining

- Are real graphs random?



Laws and patterns

- Are real graphs random?
- A: NO!!
 - Diameter
 - in- and out- degree distributions
 - other (surprising) patterns



Solution#1

- Power law in the degree distribution [SIGCOMM99]

internet domains

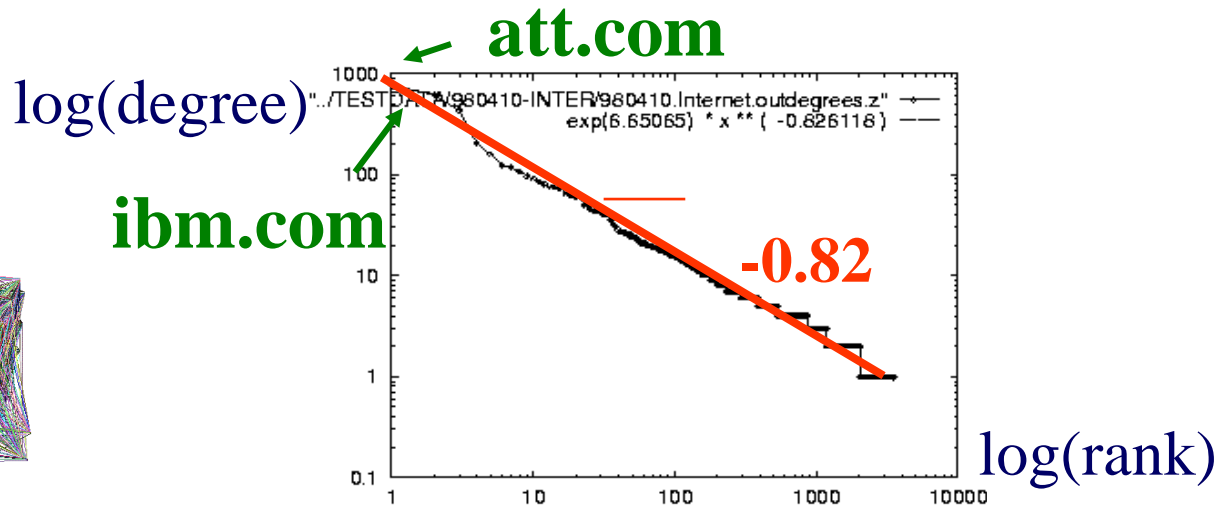
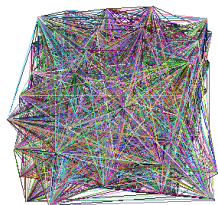



Solution#1': Eigen Exponent E

Eigenvalue

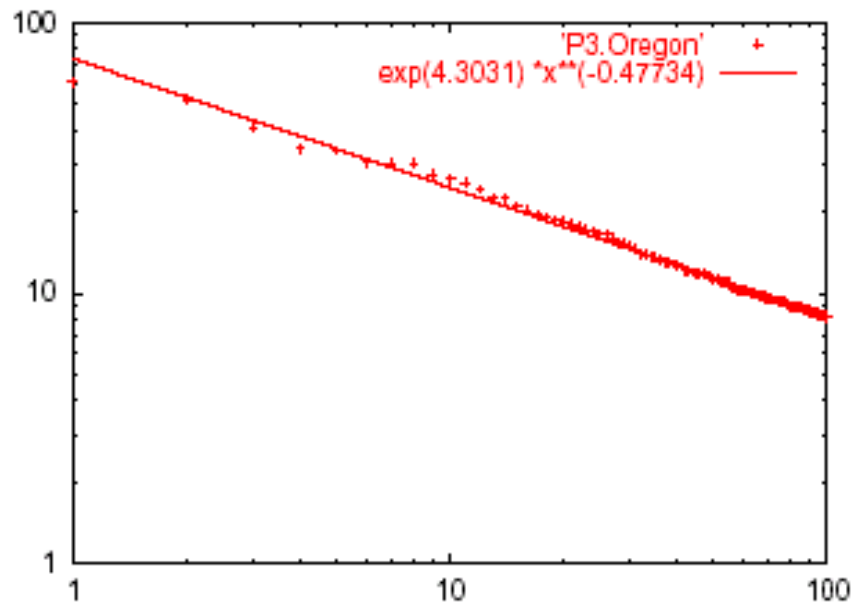

Exponent = slope

$$E = -0.48$$

May 2001

Rank of decreasing eigenvalue

- A2: power law in the eigenvalues of the adjacency matrix



Solution#1': Eigen Exponent E

Eigenvalue

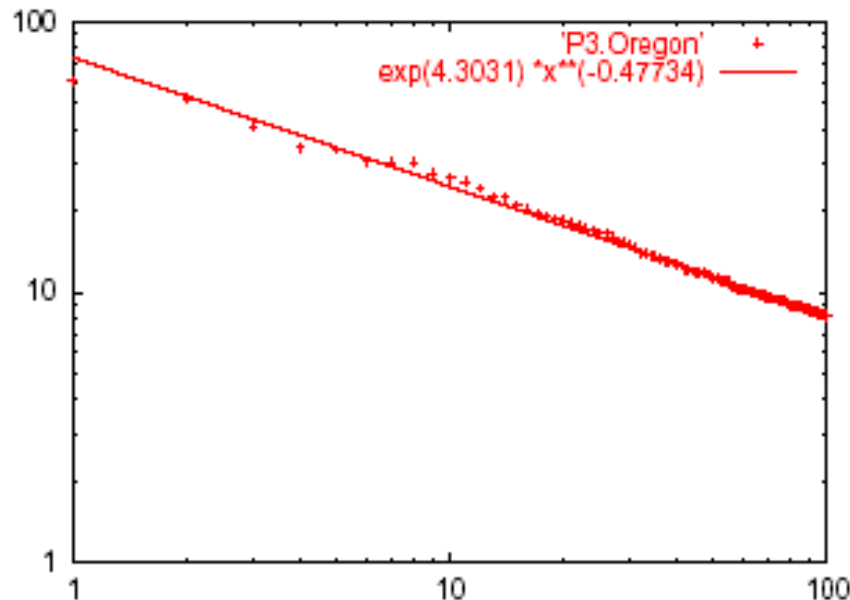

Exponent = slope

$$E = -0.48$$

May 2001

Rank of decreasing eigenvalue

- [Papadimitriou, Mihail, '02]: slope is $\frac{1}{2}$ of rank exponent



But:

How about graphs from other domains?



The Peer-to-Peer Topology

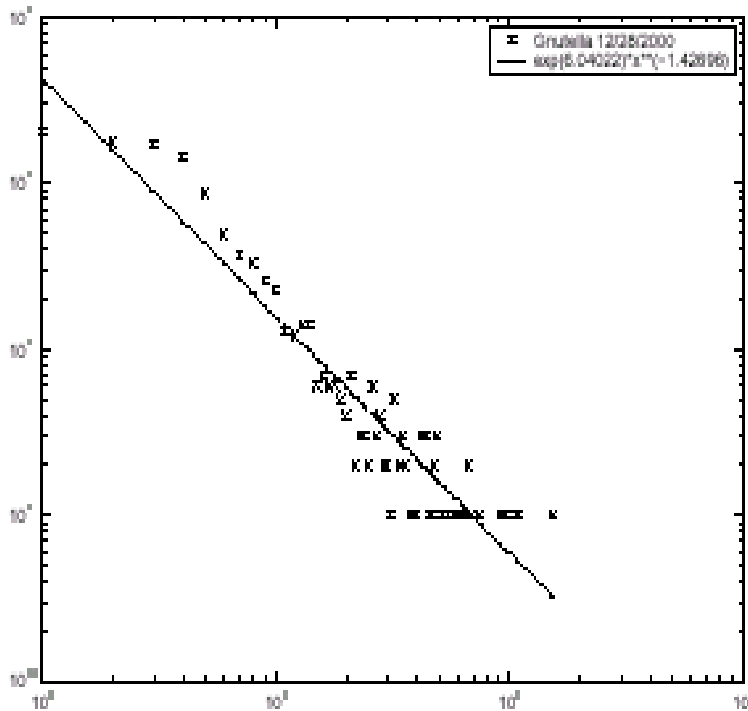

(a) Gnutella snapshot from Dec. 28, 2000 ($|r|=0.94$)

[Jovanovic+]

- Count versus degree
- Number of adjacent peers follows a power-law



More power laws:

citation counts: (*citeseer.nj.nec.com* 6/2001)

$\log(\text{count})$

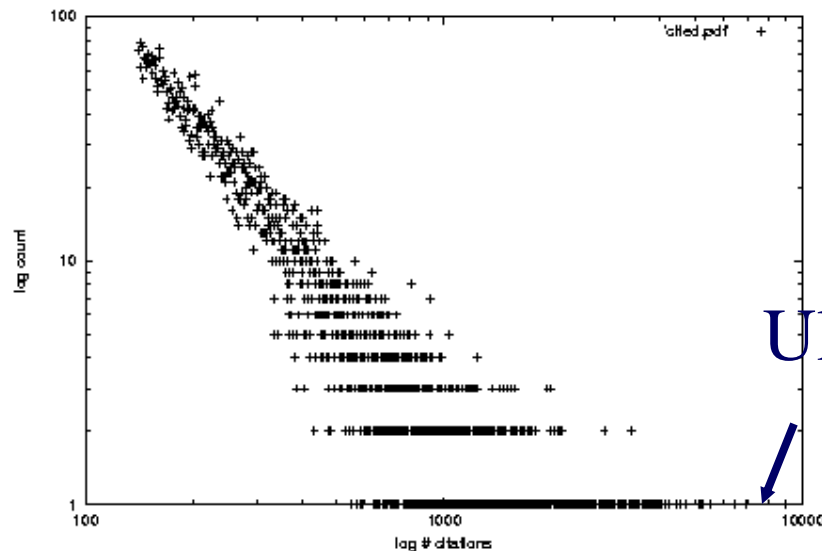

Ullman

$\log(\#\text{citations})$



More power laws:

- web hit counts [w/ A. Montgomery]

$\log(\text{count})$

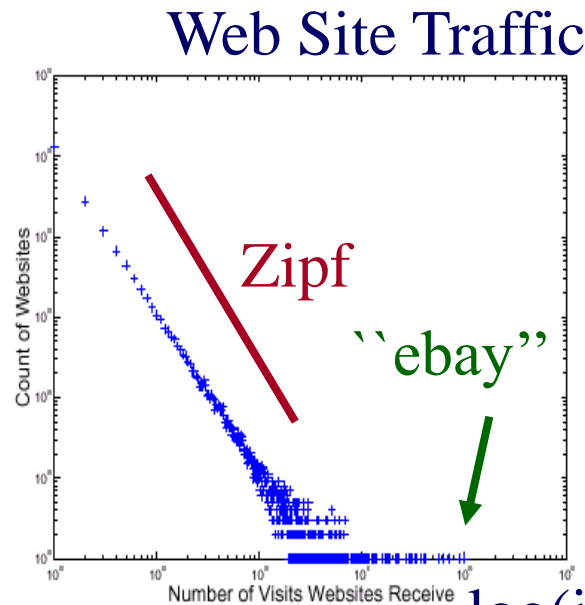

$\log(\text{in-degree})$

users

sites

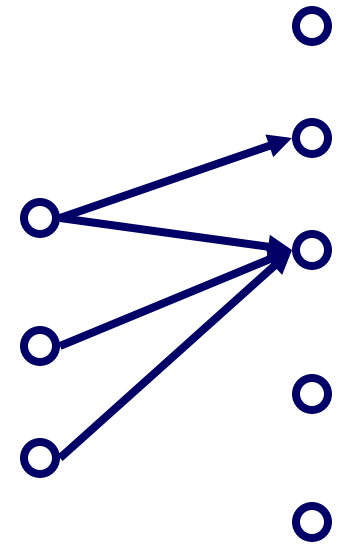



epinions.com

- who-trusts-whom [Richardson + Domingos, KDD 2001]

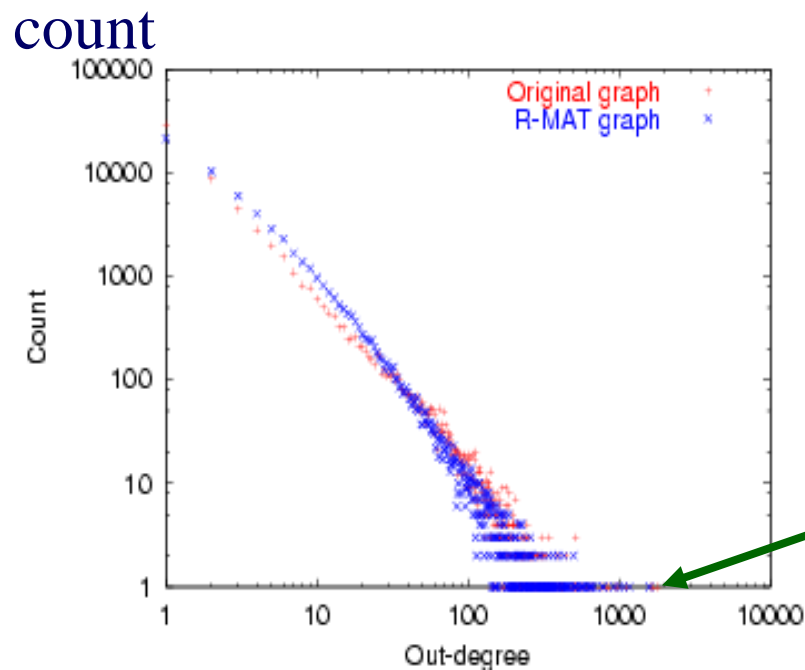

trusts-2000-people user

(out) degree



Motivation

Data mining: ~ find patterns (rules, outliers)

- ✓ Problem#1: How do real graphs look like?
- Problem#2: How do they evolve?
- Problem#3: How to generate realistic graphs

TOOLS

- Problem#4: Who is the ‘master-mind’?
- Problem#5: Track communities over time



Problem#2: Time evolution

- with Jure Leskovec
(CMU/MLD)
- and Jon Kleinberg (Cornell –
sabb. @ CMU)





Evolution of the Diameter

- Prior work on Power Law graphs hints at **slowly growing diameter**:
 - diameter $\sim O(\log N)$
 - diameter $\sim O(\log \log N)$
- What is happening in real data?



Evolution of the Diameter

- Prior work on Power Law graphs hints at **slowly growing diameter**:
 - diameter $\sim O(\log N)$
 - diameter $\sim O(\log \log N)$
- What is happening in real data?
- Diameter **shrinks** over time



Diameter – ArXiv citation graph

- Citations among physics papers
- 1992 – 2003
- One graph per year

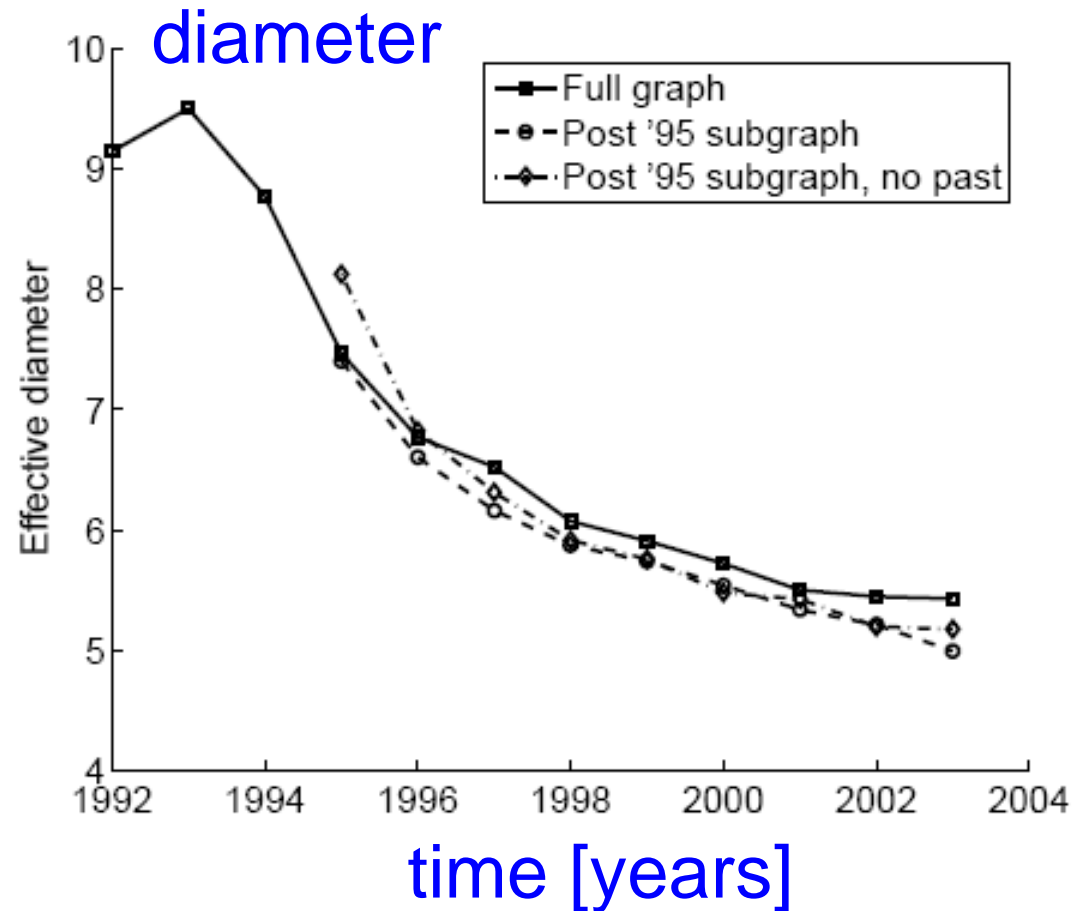



Diameter – “Autonomous Systems”

- Graph of Internet
- One graph per day
- 1997 – 2000

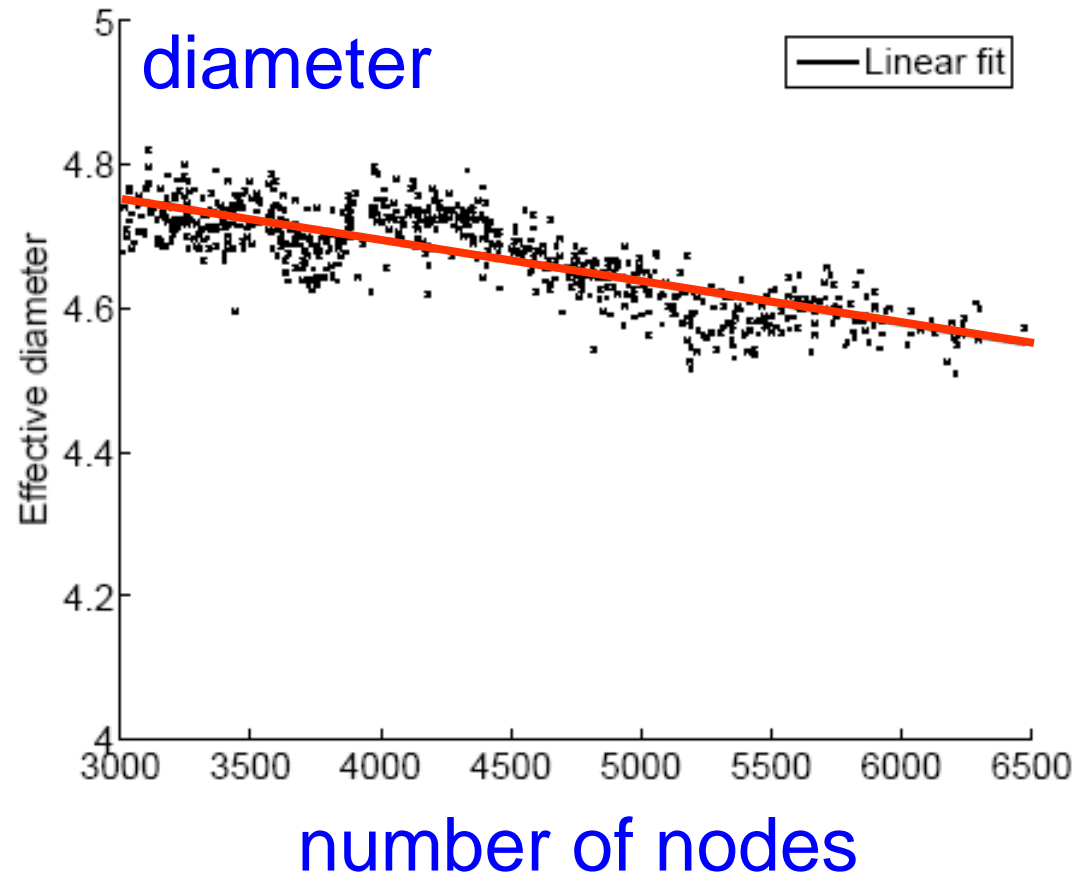



Diameter – “Affiliation Network”

- Graph of collaborations in physics – authors linked to papers
- 10 years of data

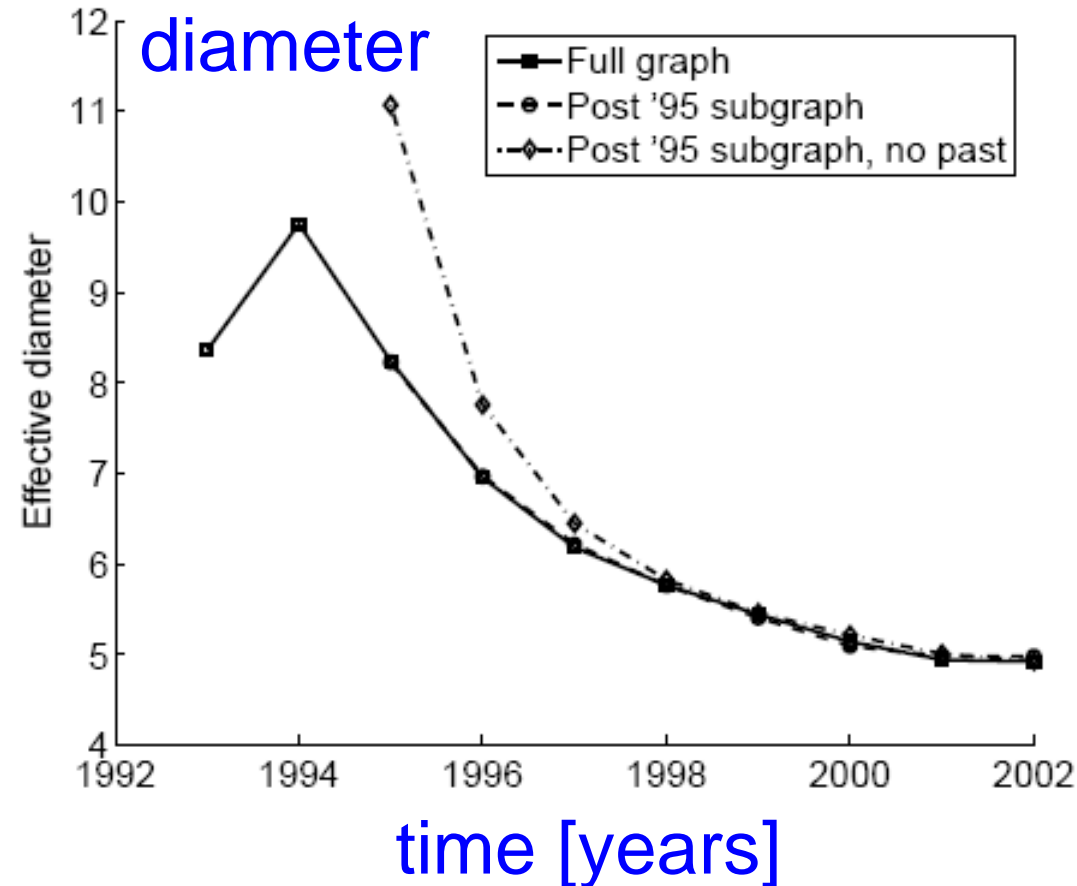



Diameter – “Patents”

- Patent citation network
- 25 years of data

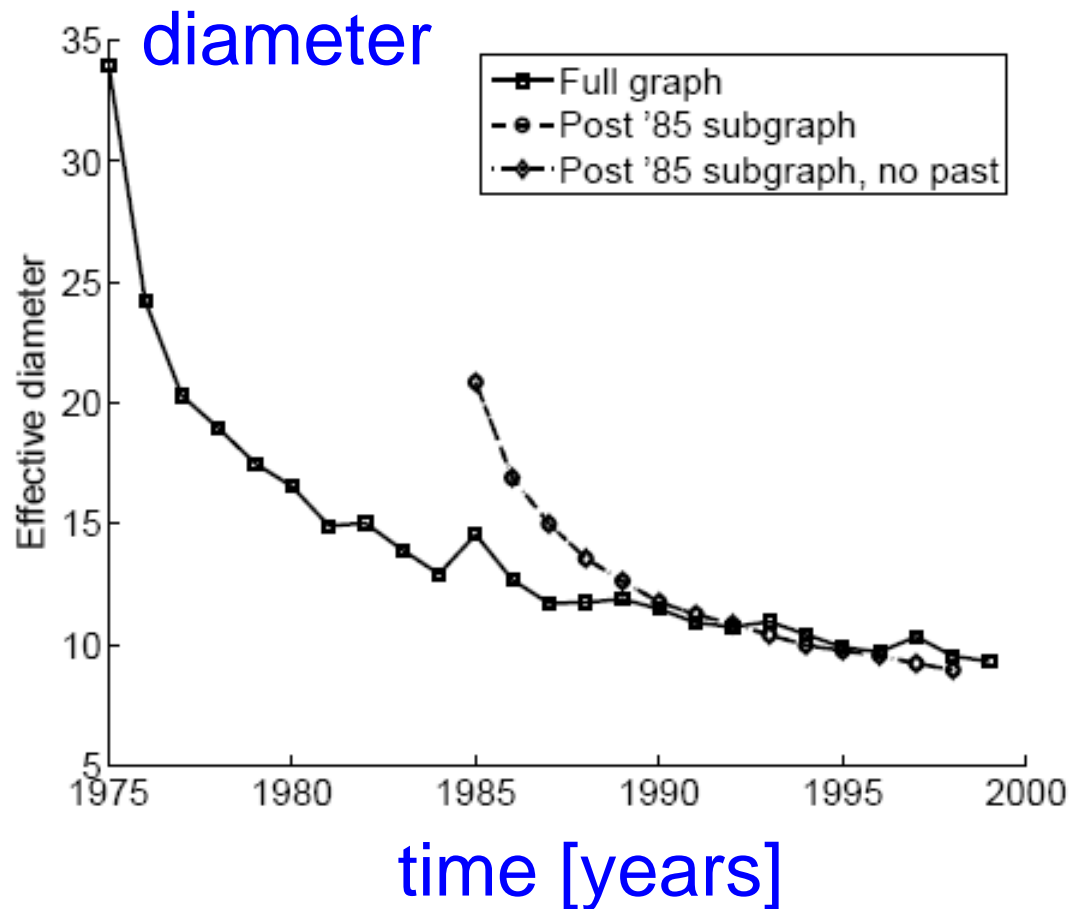



Temporal Evolution of the Graphs

- $N(t)$... nodes at time t
- $E(t)$... edges at time t
- Suppose that

$$N(t+1) = 2 * N(t)$$

- Q: what is your guess for
 $E(t+1) = ? 2 * E(t)$



Temporal Evolution of the Graphs

- $N(t)$... nodes at time t
- $E(t)$... edges at time t
- Suppose that

$$N(t+1) = 2 * N(t)$$

- Q: what is your guess for

$$E(t+1) = ? * E(t)$$

- A: over-doubled!

– But obeying the “**Densification Power Law**”



Densification – Physics Citations

- Citations among physics papers
- 2003:
 - 29,555 papers,
352,807 citations

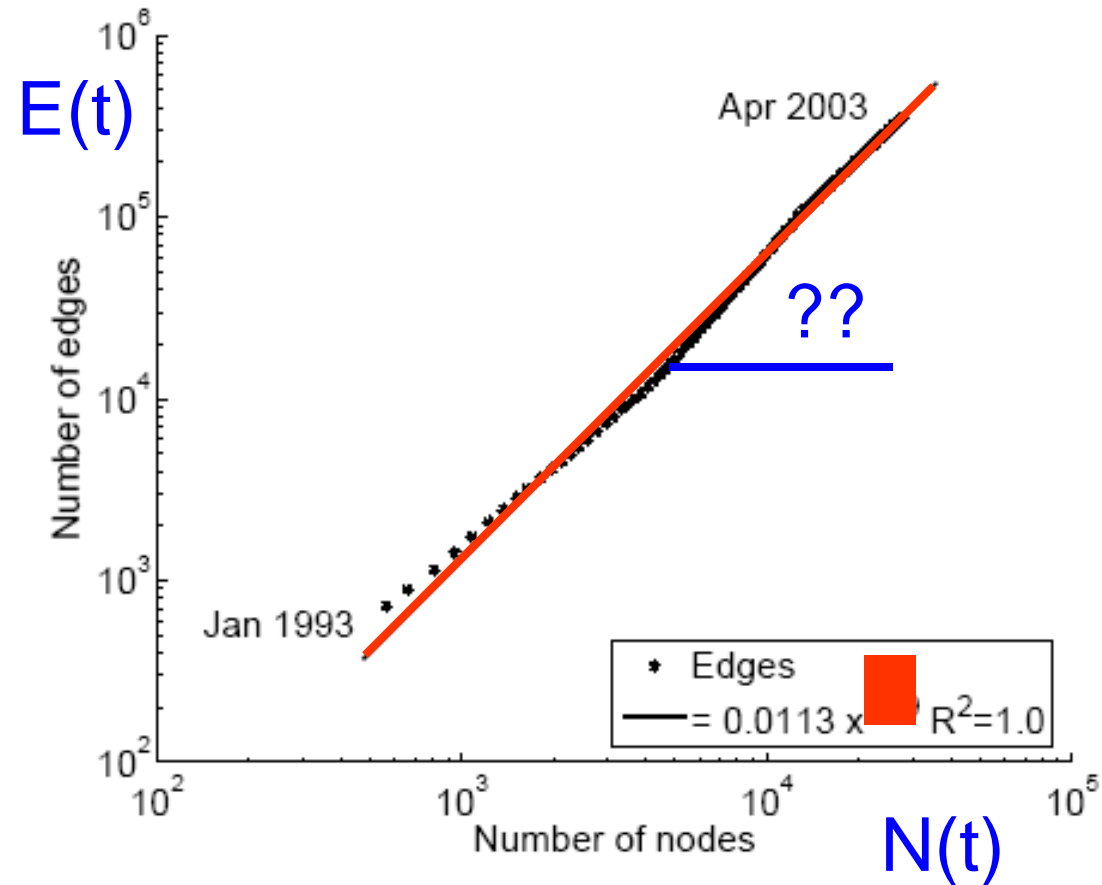



Densification – Physics Citations

- Citations among physics papers
- 2003:
 - 29,555 papers, 352,807 citations

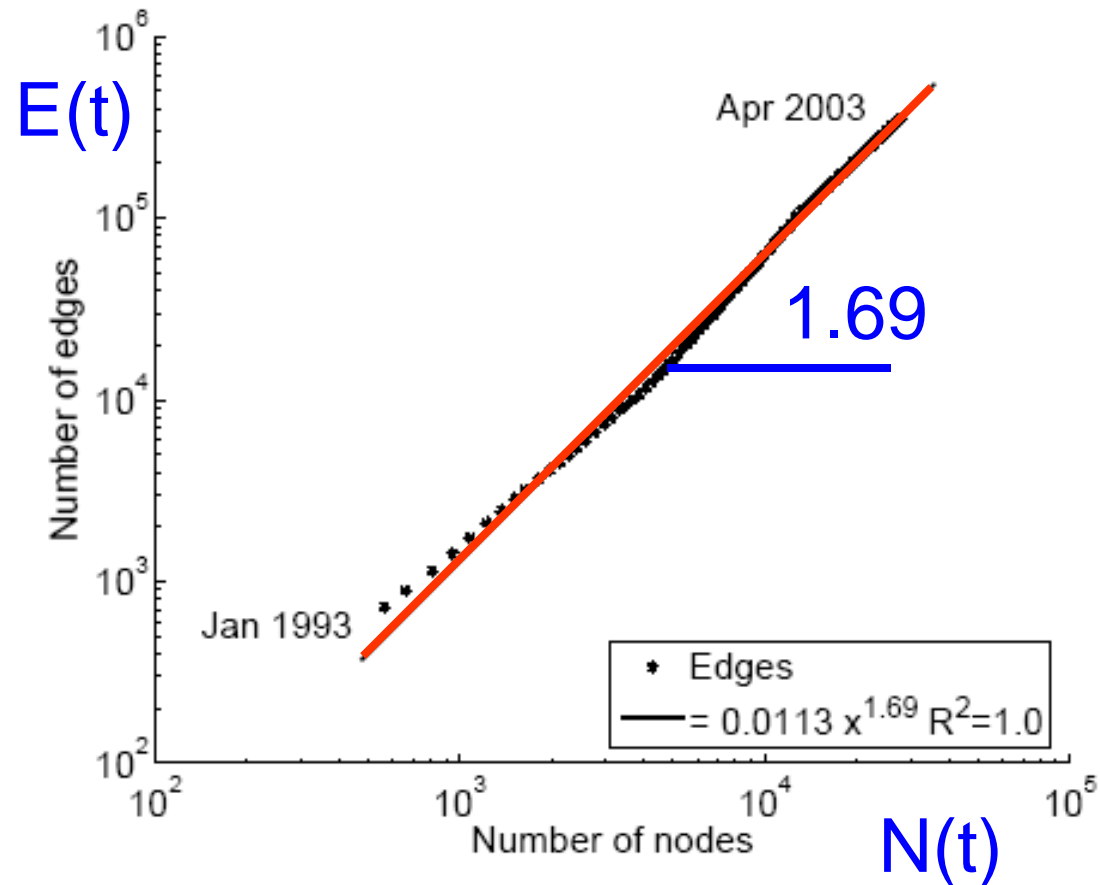



Densification – Physics Citations

- Citations among physics papers
- 2003:
 - 29,555 papers, 352,807 citations

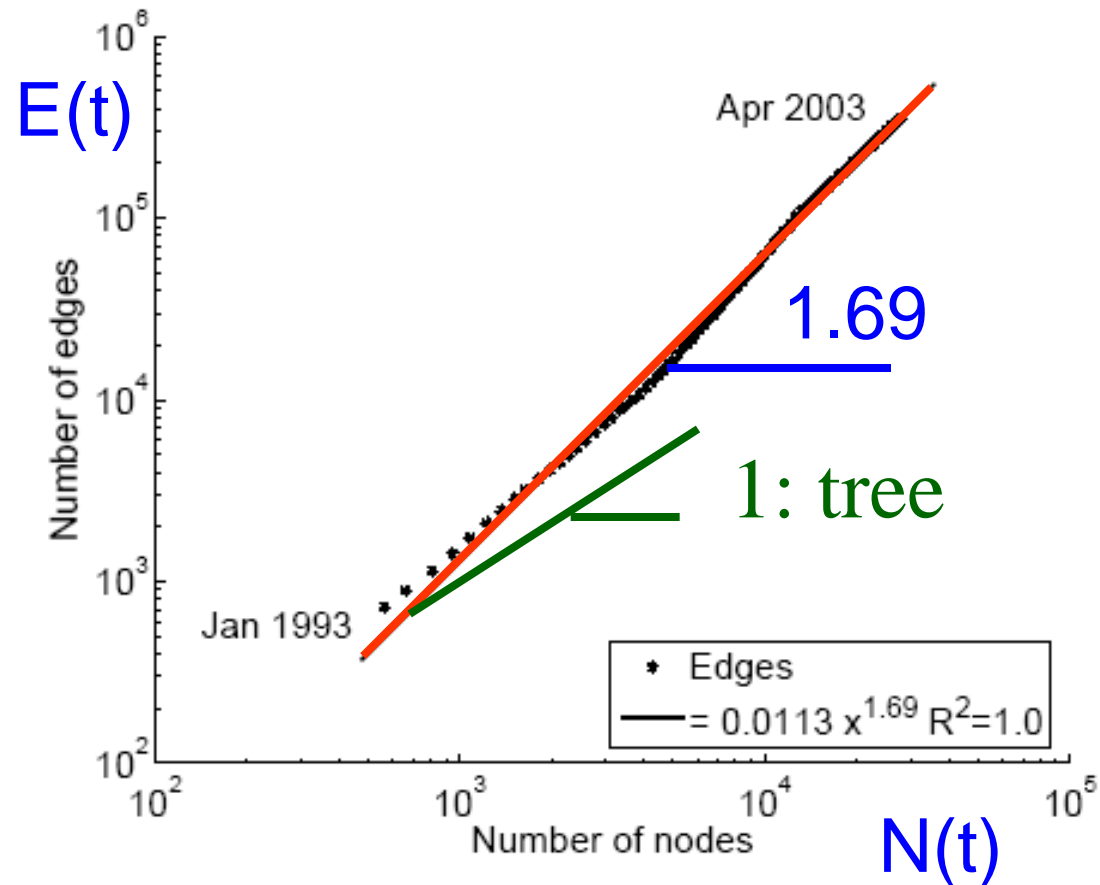



Densification – Physics Citations

- Citations among physics papers
- 2003:
 - 29,555 papers, 352,807 citations

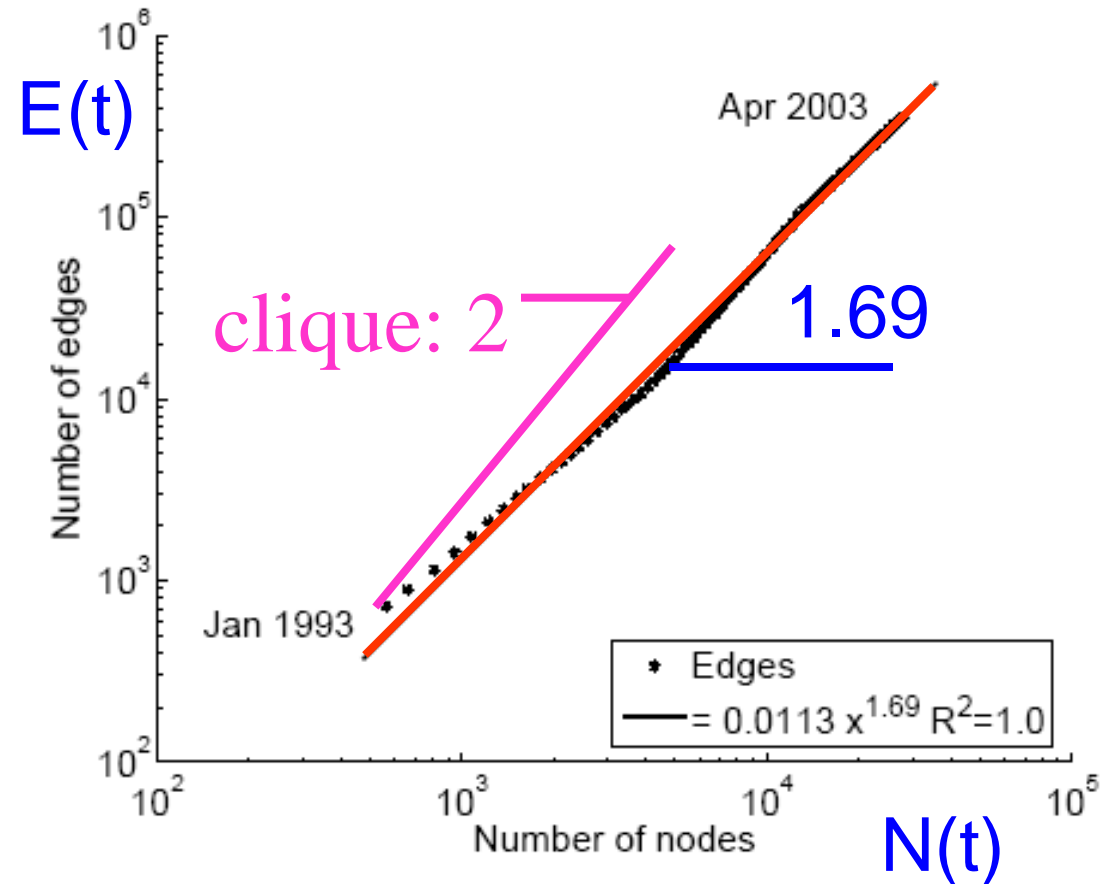



Densification – Patent Citations

- Citations among patents granted
- 1999
 - 2.9 million nodes
 - 16.5 million edges
- Each year is a datapoint

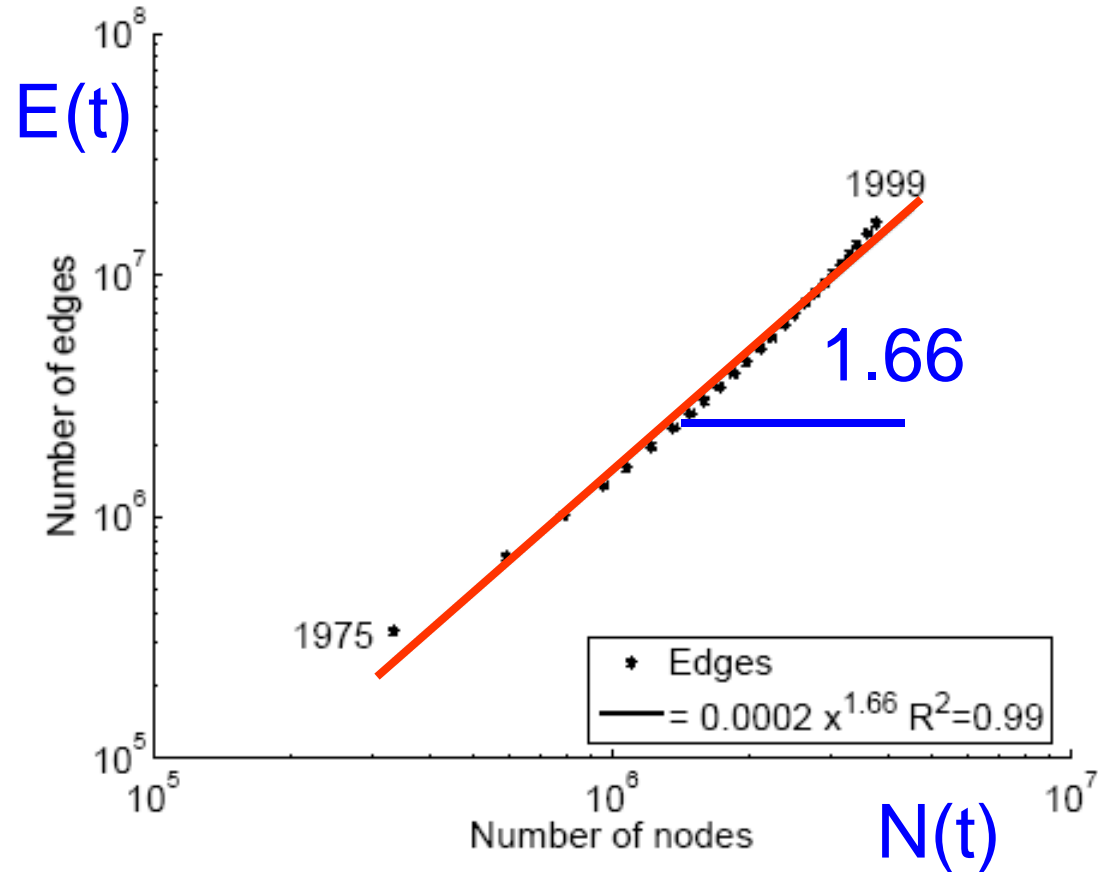



Densification – Autonomous Systems

- Graph of Internet
- 2000
 - 6,000 nodes
 - 26,000 edges
- One graph per day

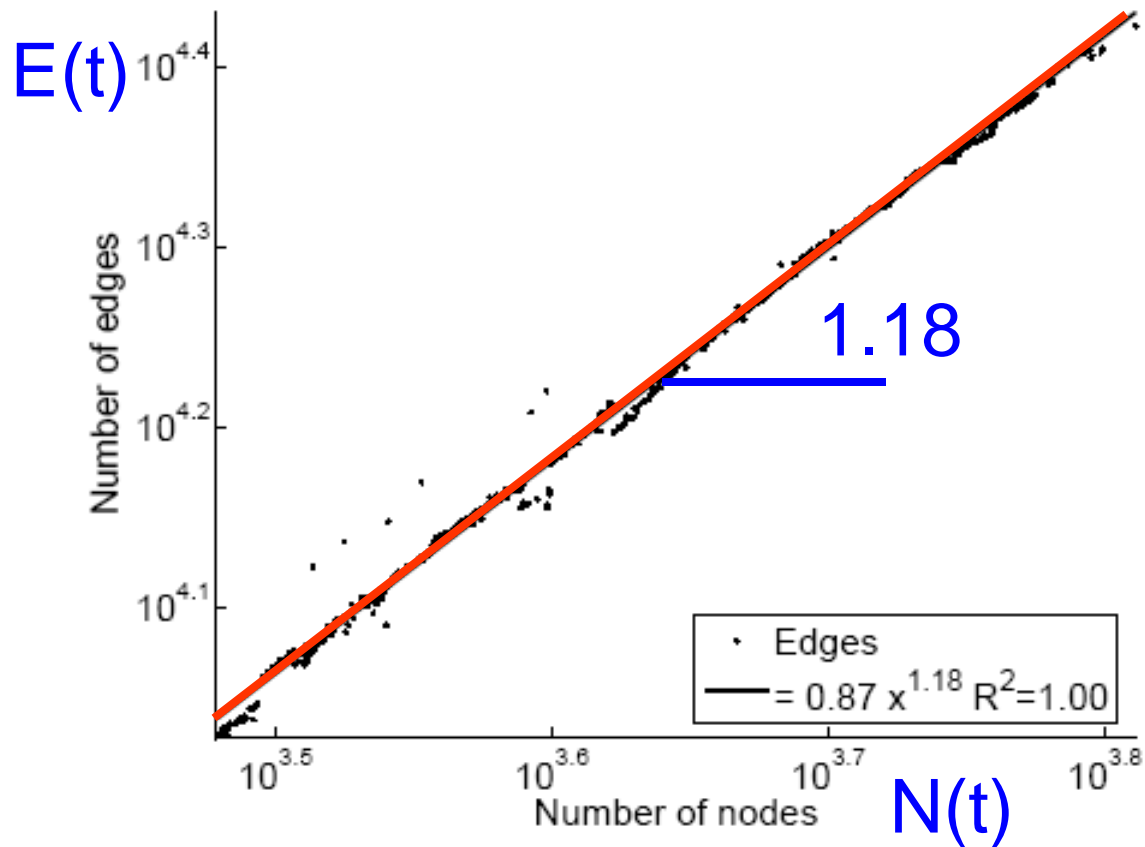



Densification – Affiliation Network

- Authors linked to their publications
- 2002
 - 60,000 nodes
 - 20,000 authors
 - 38,000 papers
 - 133,000 edges

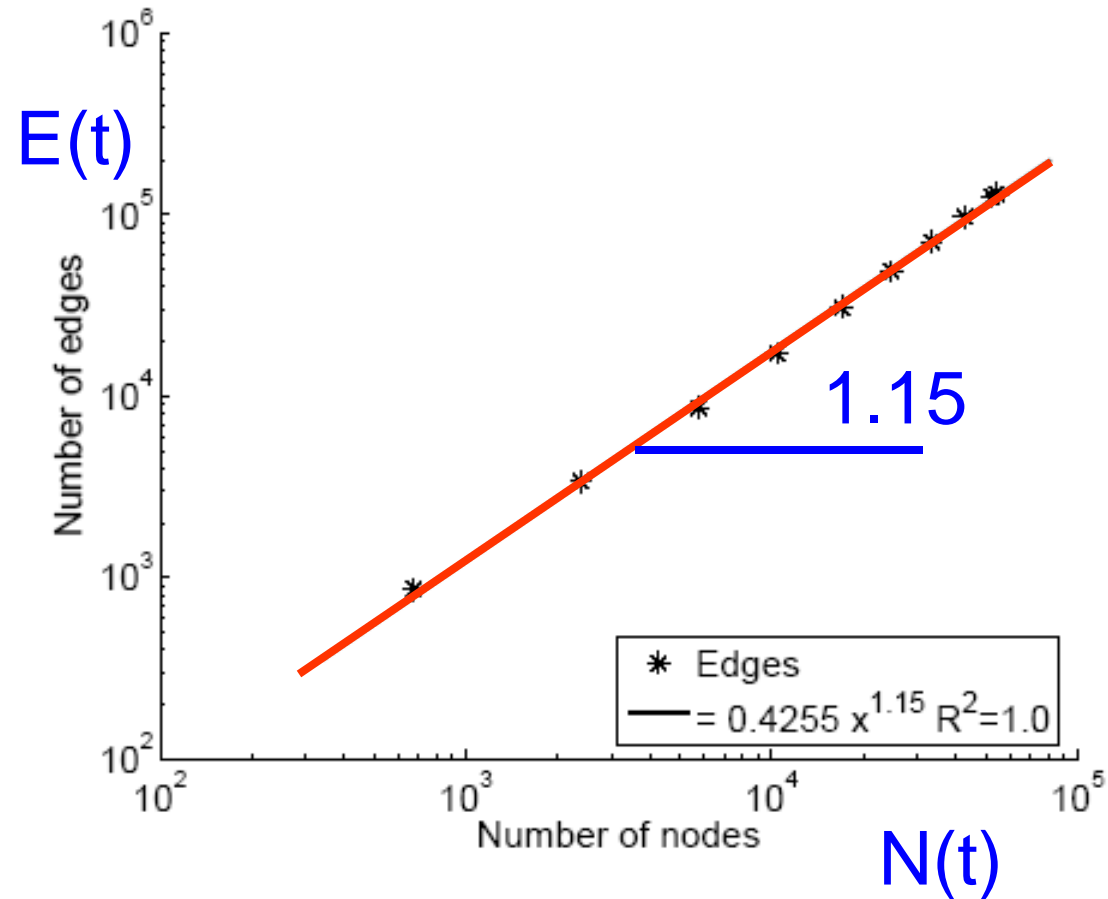



Motivation

Data mining: ~ find patterns (rules, outliers)

- ✓ Problem#1: How do real graphs look like?
- ✓ Problem#2: How do they evolve?
- Problem#3: How to generate realistic graphs

TOOLS

- Problem#4: Who is the ‘master-mind’?
- Problem#5: Track communities over time



Problem#3: Generation

- Given a growing graph with count of nodes N_1 , N_2 , ...
- Generate a realistic sequence of graphs that will obey all the patterns



Problem Definition

- Given a growing graph with count of nodes N_1, N_2, \dots
- Generate a realistic sequence of graphs that will obey all the patterns
 - Static Patterns
 - Power Law Degree Distribution
 - Power Law eigenvalue and eigenvector distribution
 - Small Diameter
 - Dynamic Patterns
 - Growth Power Law
 - Shrinking/Stabilizing Diameters



Problem Definition

- Given a growing graph with count of nodes N_1, N_2, \dots
- Generate a realistic sequence of graphs that will obey all the patterns
- **Idea: Self-similarity**
 - Leads to power laws
 - Communities within communities
 - ...



Kronecker Product – a Graph

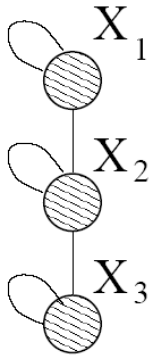

1	1	0
1	1	1
0	1	1

 G_1

Adjacency matrix



Kronecker Product – a Graph

- Continuing multiplying with G_1 we obtain G_4 and so on ...

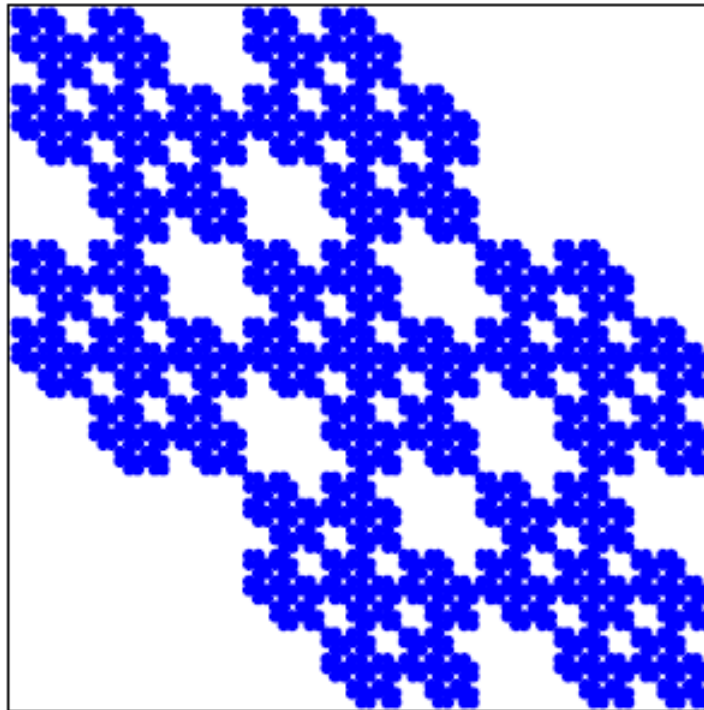

G_4 adjacency matrix

C. Faloutsos



Kronecker Product – a Graph

- Continuing multiplying with G_1 we obtain G_4 and so on ...

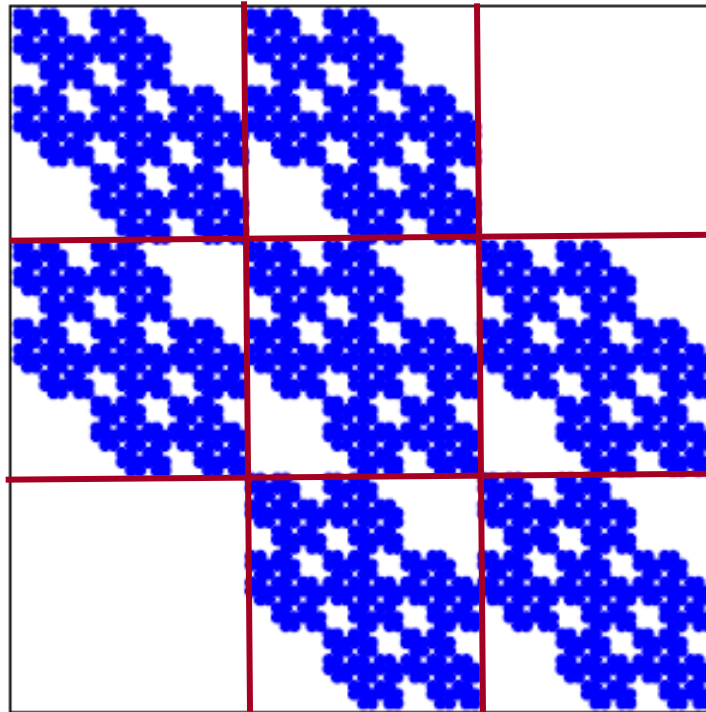

G_4 adjacency matrix

C. Faloutsos



Kronecker Product – a Graph

- Continuing multiplying with G_1 we obtain G_4 and so on ...

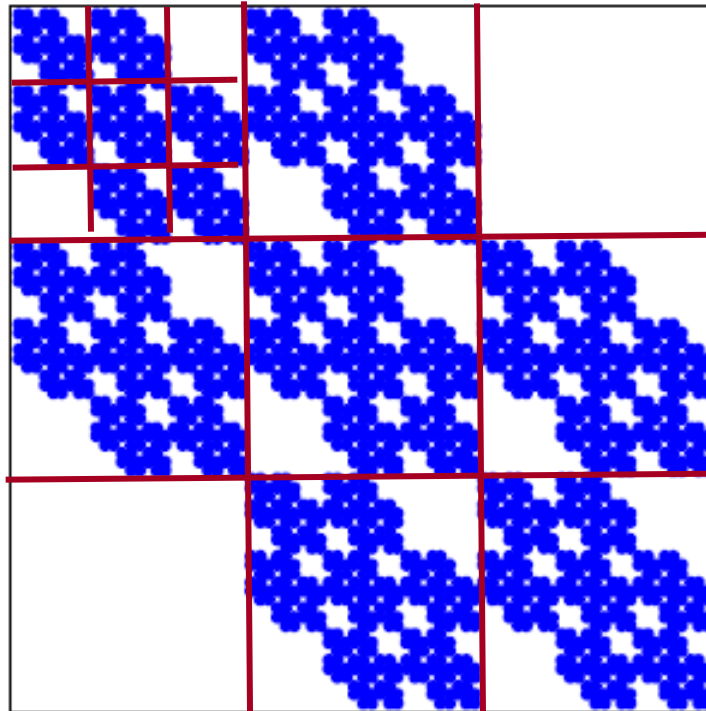

G_4 adjacency matrix



Properties:

- We can PROVE that
 - Degree distribution is multinomial \sim power law
 - Diameter: constant
 - Eigenvalue distribution: multinomial
 - First eigenvector: multinomial
- See [Leskovec+, PKDD'05] for proofs



Problem Definition

- Given a growing graph with nodes N_1, N_2, \dots
- Generate a realistic sequence of graphs that will obey all the patterns
 - Static Patterns
 - ✓ Power Law Degree Distribution
 - ✓ Power Law eigenvalue and eigenvector distribution
 - ✓ Small Diameter
 - Dynamic Patterns
 - ✓ Growth Power Law
 - ✓ Shrinking/Stabilizing Diameters
- First and only generator for which we can **prove** all these properties



Stochastic Kronecker Graphs

- Create $N_1 \times N_1$ probability matrix P_1
- Compute the k^{th} Kronecker power P_k
- For each entry p_{uv} of P_k include an edge (u, v) with probability p_{uv}

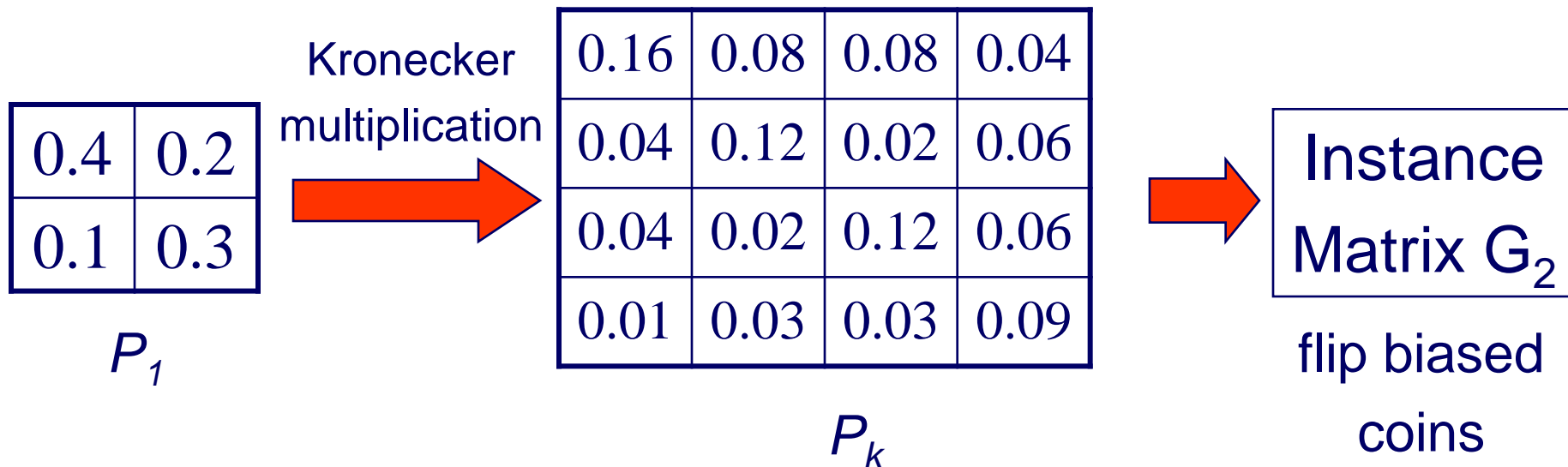



Experiments

- How well can we match real graphs?
 - Arxiv: physics citations:
 - 30,000 papers, 350,000 citations
 - 10 years of data
 - U.S. Patent citation network
 - 4 million patents, 16 million citations
 - 37 years of data
 - Autonomous systems – graph of internet
 - Single snapshot from January 2002
 - 6,400 nodes, 26,000 edges
- We show both static and temporal patterns



(Q: how to fit the parm's?)

A:

- Stochastic version of Kronecker graphs +
- Max likelihood +
- Metropolis sampling
- [Leskovec+, ICML'07]



Experiments on real AS graph

Degree distribution

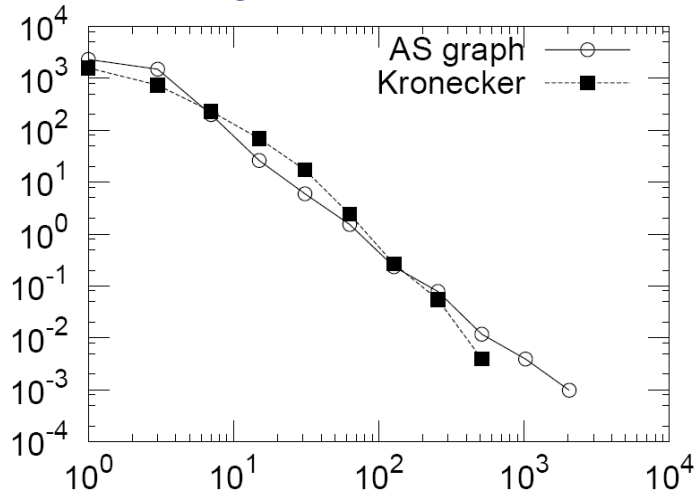

Hop plot

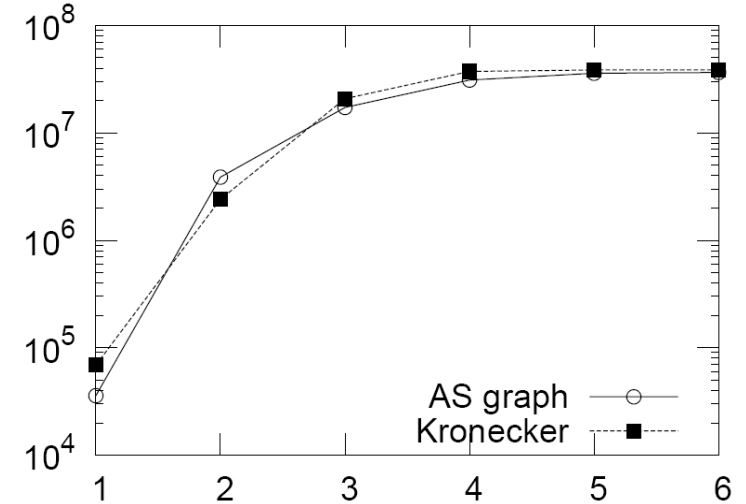

Adjacency matrix eigen values

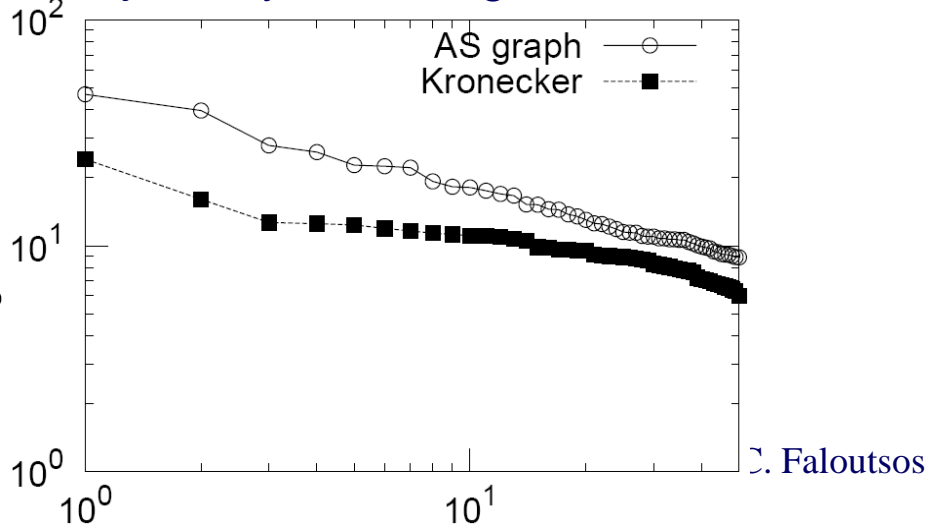

J. Faloutsos

Network value

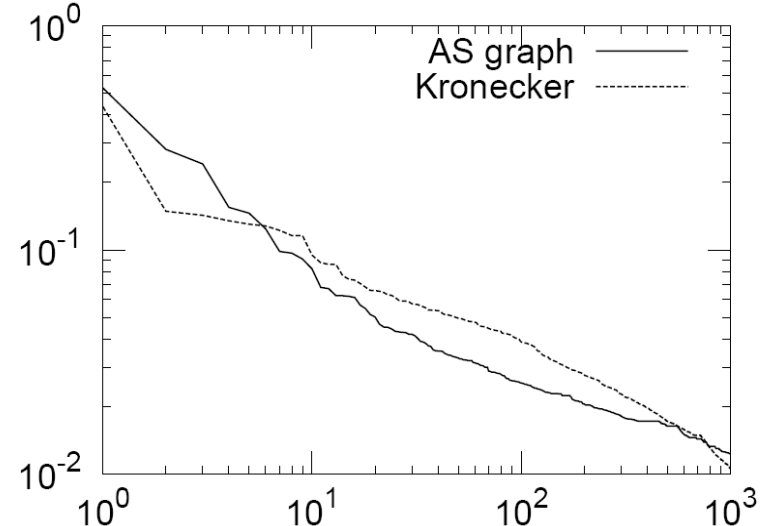



Conclusions

- Kronecker graphs have:
 - All the **static** properties
 - ✓ Heavy tailed degree distributions
 - ✓ Small diameter
 - ✓ Multinomial eigenvalues and eigenvectors
 - All the **temporal** properties
 - ✓ Densification Power Law
 - ✓ Shrinking/Stabilizing Diameters
 - We can formally **prove** these results



Motivation

Data mining: ~ find patterns (rules, outliers)

- ✓ Problem#1: How do real graphs look like?
- ✓ Problem#2: How do they evolve?
- ✓ Problem#3: How to generate realistic graphs

TOOLS

- ➔ Problem#4: Who is the ‘master-mind’?
- Problem#5: Track communities over time



Problem#4: MasterMind – ‘CePS’

- w/ Hanghang Tong,
KDD 2006
- htong <at> cs.cmu.edu





Center-Piece Subgraph(Ceps)

- **Given** Q query nodes
- **Find** Center-piece ($\leq b$)
- **App.**
 - Social Networks
 - Law Enforcement, ...
- **Idea:**
 - Proximity \rightarrow random walk with restarts

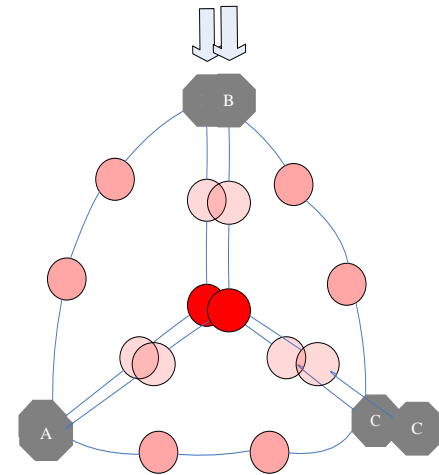
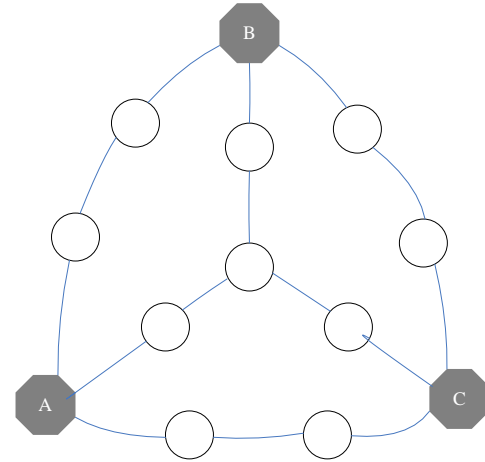



Case Study: AND query

R. Agrawal

Jiawei Han

V. Vapnik

M. Jordan



Case Study: AND query

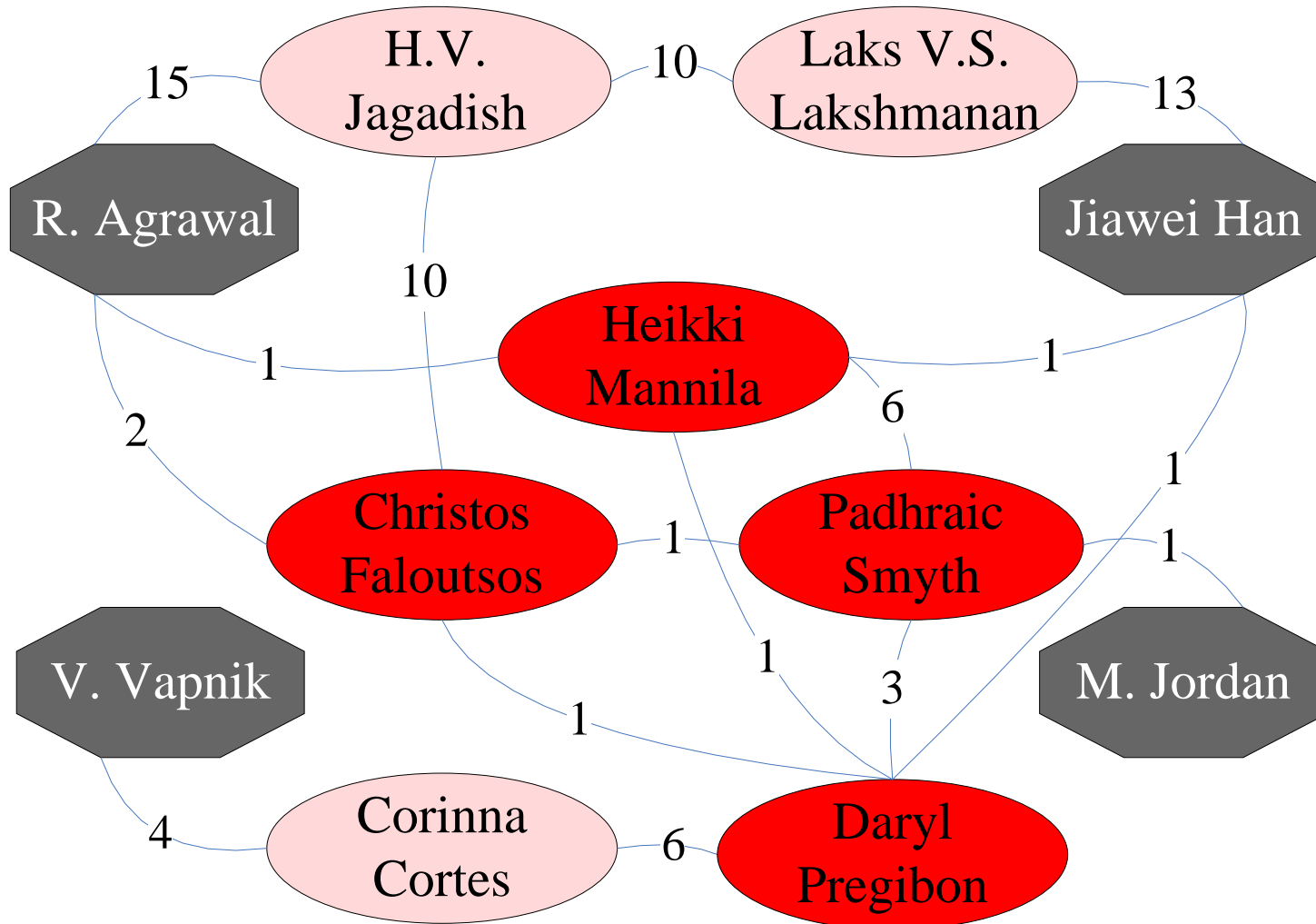



Case Study: AND query

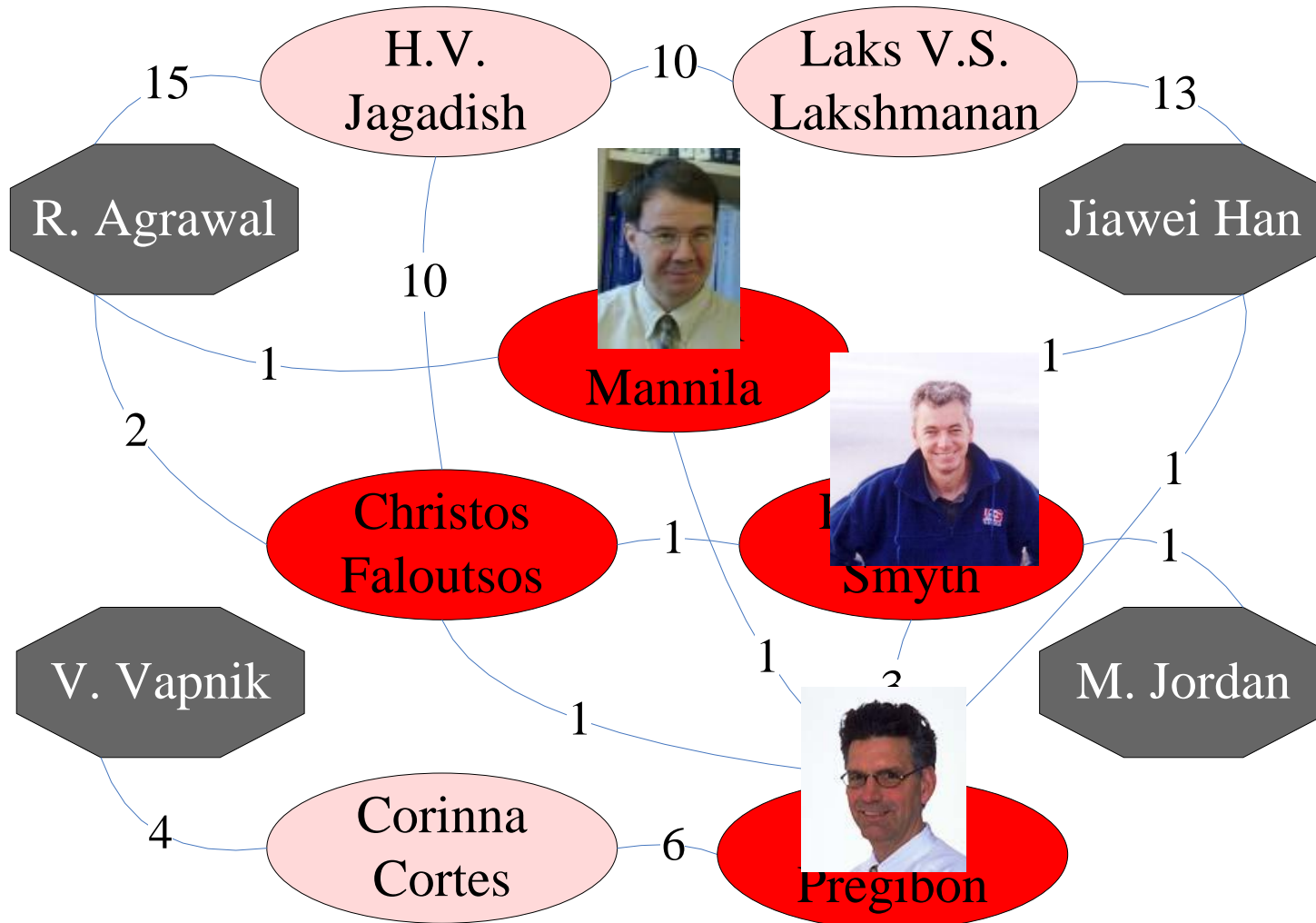

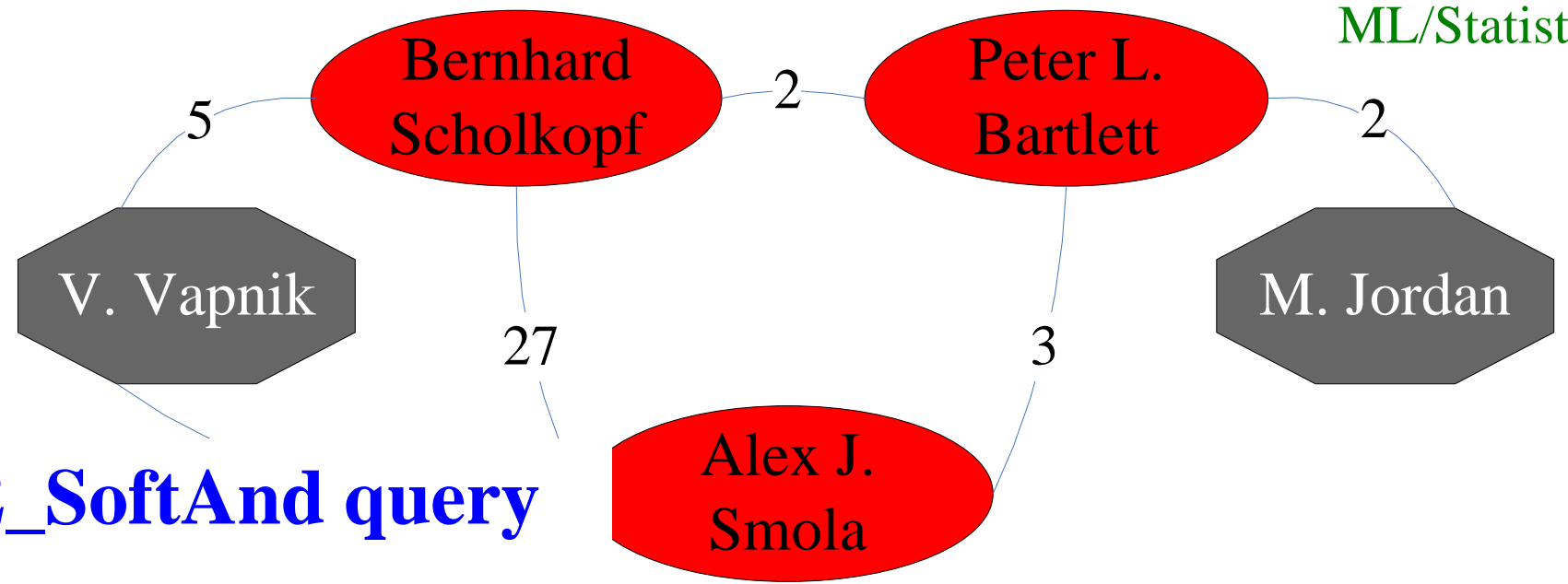
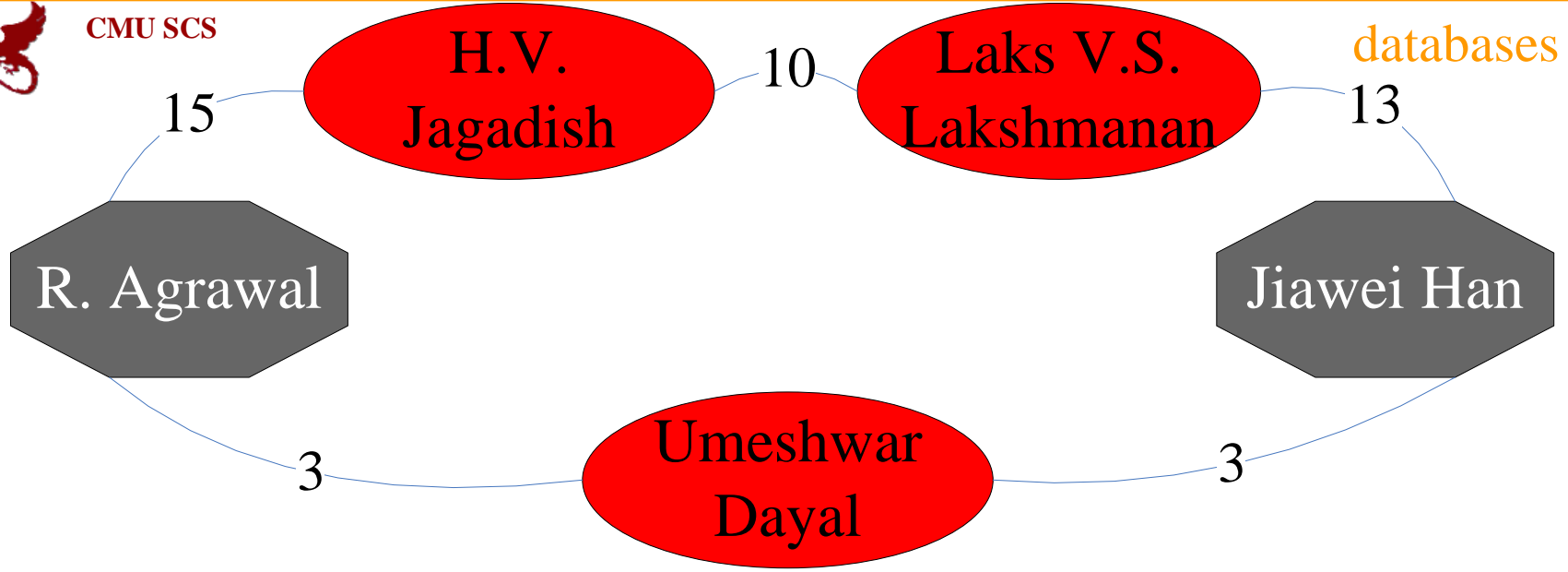

2_SoftAnd query



Conclusions

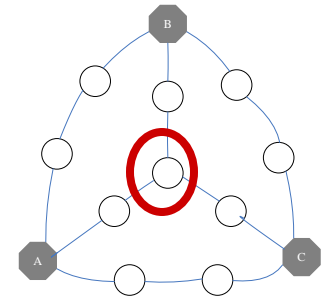

- Q1:How to measure the importance?
- A1: RWR+K_SoftAnd
- Q2:How to do it efficiently?
- A2:Graph Partition (Fast CePS)
 - ~90% quality
 - 150x speedup (ICDM'06, b.p. award)



Outline

- Problem definition / Motivation
- Static & dynamic laws; generators
- ➔ Tools: CenterPiece graphs; **Tensors**
- Other projects (Virus propagation, e-bay fraud detection)
- Conclusions



Motivation

Data mining: ~ find patterns (rules, outliers)

- ✓ Problem#1: How do real graphs look like?
- ✓ Problem#2: How do they evolve?
- ✓ Problem#3: How to generate realistic graphs

TOOLS

- ✓ Problem#4: Who is the ‘master-mind’?
- Problem#5: Track communities over time



Tensors for time evolving graphs

- [Jimeng Sun+
KDD'06]
- [“ , SDM'07]
- [CF, Kolda, Sun,
SDM'07 tutorial]





Social network analysis

- **Static:** find community structures

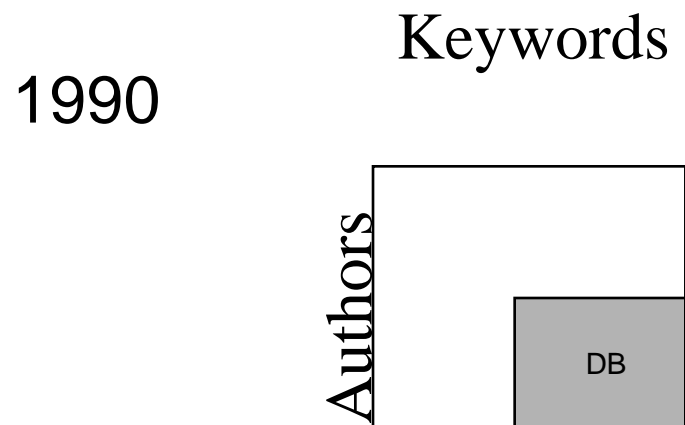



Social network analysis

- **Static:** find community structures

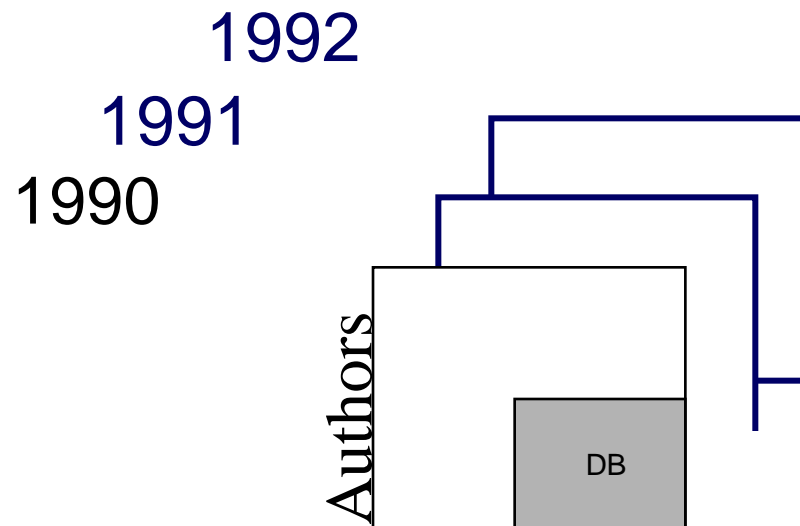



Social network analysis

- **Static**: find community structures
- **Dynamic**: monitor community structure evolution; spot abnormal individuals; abnormal time-stamps

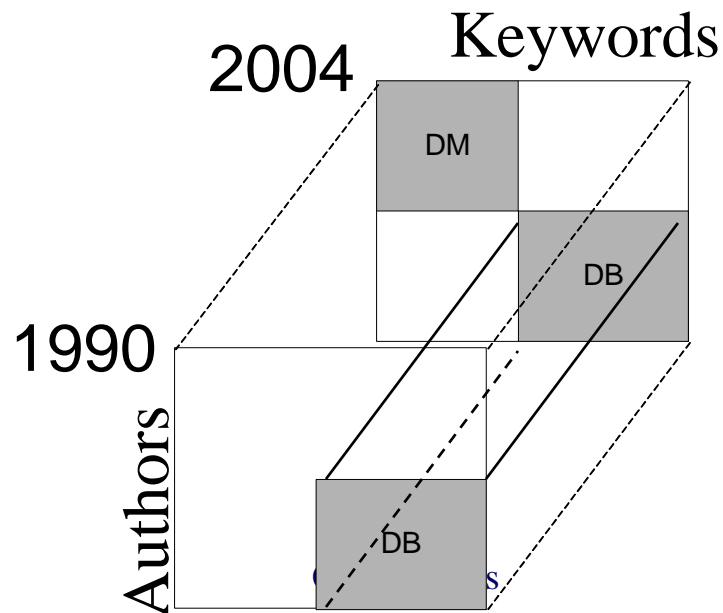



Application 1: Multiway latent semantic indexing (LSI)

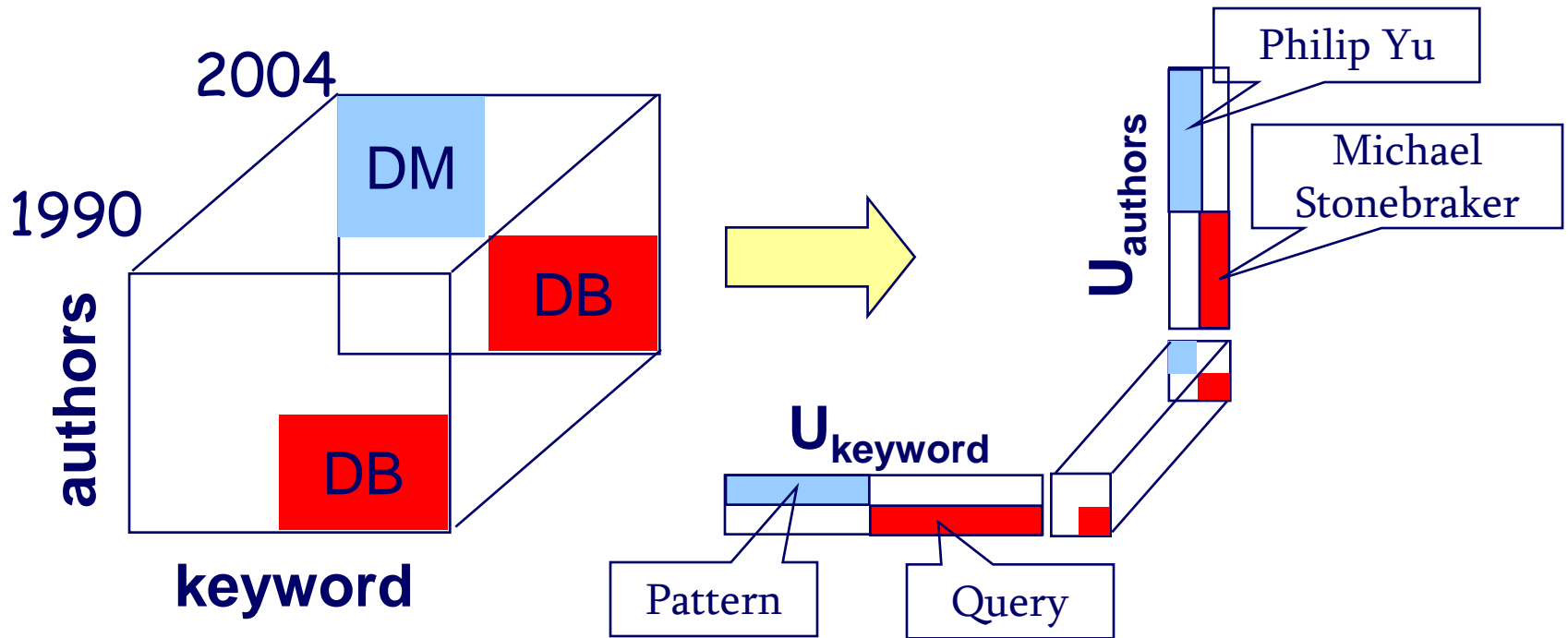

- Projection matrices specify the clusters
- Core tensors give cluster activation level



Bibliographic data (DBLP)

- Papers from VLDB and KDD conferences
- Construct 2nd order tensors with yearly windows with <author, keywords>
- Each tensor: 4584×3741
- 11 timestamps (years)



Multiway LSI

Authors	Keywords	Year
michael carey, michael stonebraker, h. jagadish, hector garcia-molina	query, parallel, optimization, concurr, objectorient	1995
surajit chaudhuri, mitch cherniack, michael stonebraker, ugur etintemel	distributed, systems, view, storage, servic, process, cache	2004
jiawei han, jian pei, philip s. yu, jianyong wang, charu c. aggarwal	streams, pattern, support, cluster, gener, query	2004

DB

DM

- Two groups are correctly identified: Databases and Data mining
- People and concepts are drifting over time



Network forensics

- Directional network flows
- A large ISP with 100 POPs, each POP 10Gbps link capacity [Hotnets2004]
 - 450 GB/hour with compression
- Task: Identify abnormal traffic pattern and find out the cause

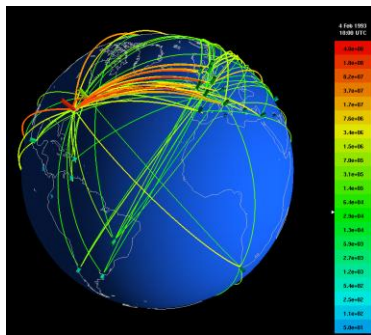

abnormal traffic

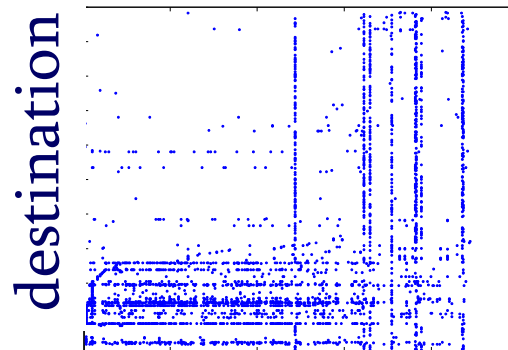

source

normal traffic

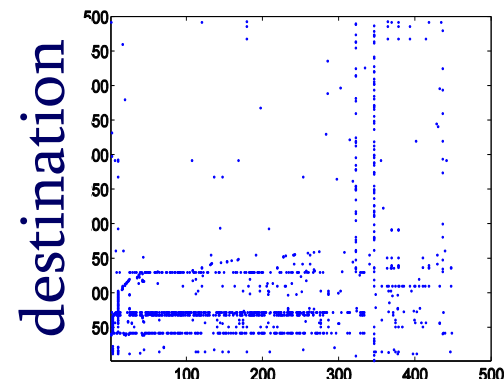

source



Conclusions

Tensor-based methods (WTA/DTA/STA):

- spot patterns and anomalies on time evolving graphs, and
- on streams (monitoring)



Motivation

Data mining: ~ find patterns (rules, outliers)

- ✓ Problem#1: How do real graphs look like?
- ✓ Problem#2: How do they evolve?
- ✓ Problem#3: How to generate realistic graphs

TOOLS

- ✓ Problem#4: Who is the ‘master-mind’?
- ✓ Problem#5: Track communities over time



Outline

- Problem definition / Motivation
- Static & dynamic laws; generators
- Tools: CenterPiece graphs; Tensors
- ➔ Other projects (Virus propagation, e-bay fraud detection, blogs)
- Conclusions





Virus propagation

- How do viruses/rumors propagate?
- Blog influence?
- Will a flu-like virus linger, or will it become extinct soon?



The model: SIS

- ‘Flu’ like: Susceptible-Infected-Susceptible
- Virus ‘strength’ $s = \beta / \delta$

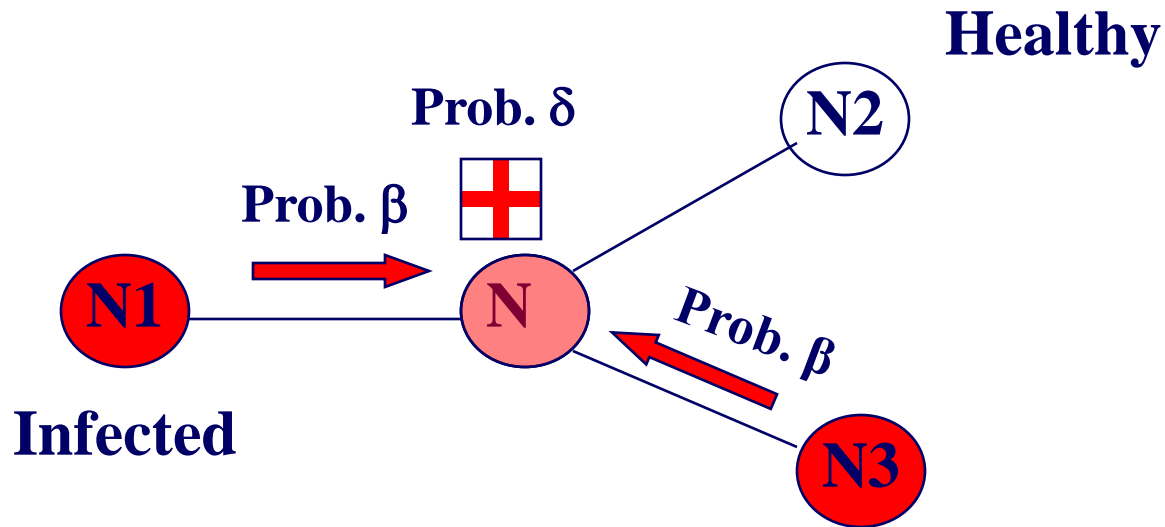



Epidemic threshold τ

of a graph: the value of τ , such that

$$\text{if strength } s = \beta / \delta < \tau$$

an epidemic can not happen

Thus,

- given a graph
- compute its epidemic threshold



Epidemic threshold τ

What should τ depend on?

- avg. degree? and/or highest degree?
- and/or variance of degree?
- and/or third moment of degree?
- and/or diameter?

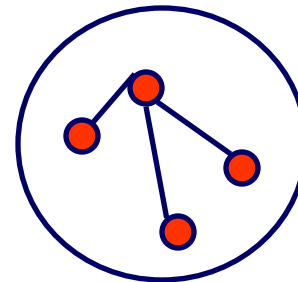
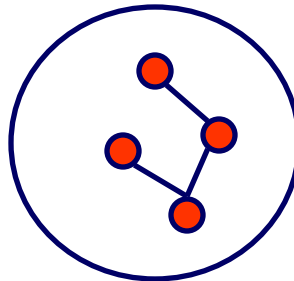
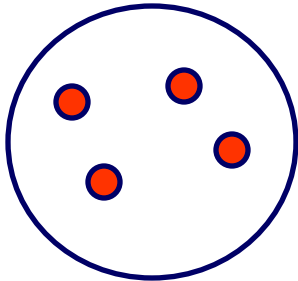



Epidemic threshold

- [Theorem] We have no epidemic, if

$$\beta/\delta < \tau = 1/\lambda_{1,A}$$



Epidemic threshold

- [Theorem] We have no epidemic, if

recovery prob. $\beta/\delta < \tau = 1/\lambda_{1,A}$ epidemic threshold

attack prob. β/δ largest eigenvalue of adj. matrix A

The diagram shows the equation $\beta/\delta < \tau = 1/\lambda_{1,A}$ enclosed in a black rectangular box. Three arrows point to different parts of the equation: a blue arrow from the text 'recovery prob.' points to β/δ ; a blue arrow from the text 'epidemic threshold' points to τ ; and a red arrow from the text 'largest eigenvalue of adj. matrix A' points to $\lambda_{1,A}$. The text 'attack prob.' is located below the box with a blue arrow pointing to β/δ .

Proof: [Wang+03]



Experiments (Oregon)

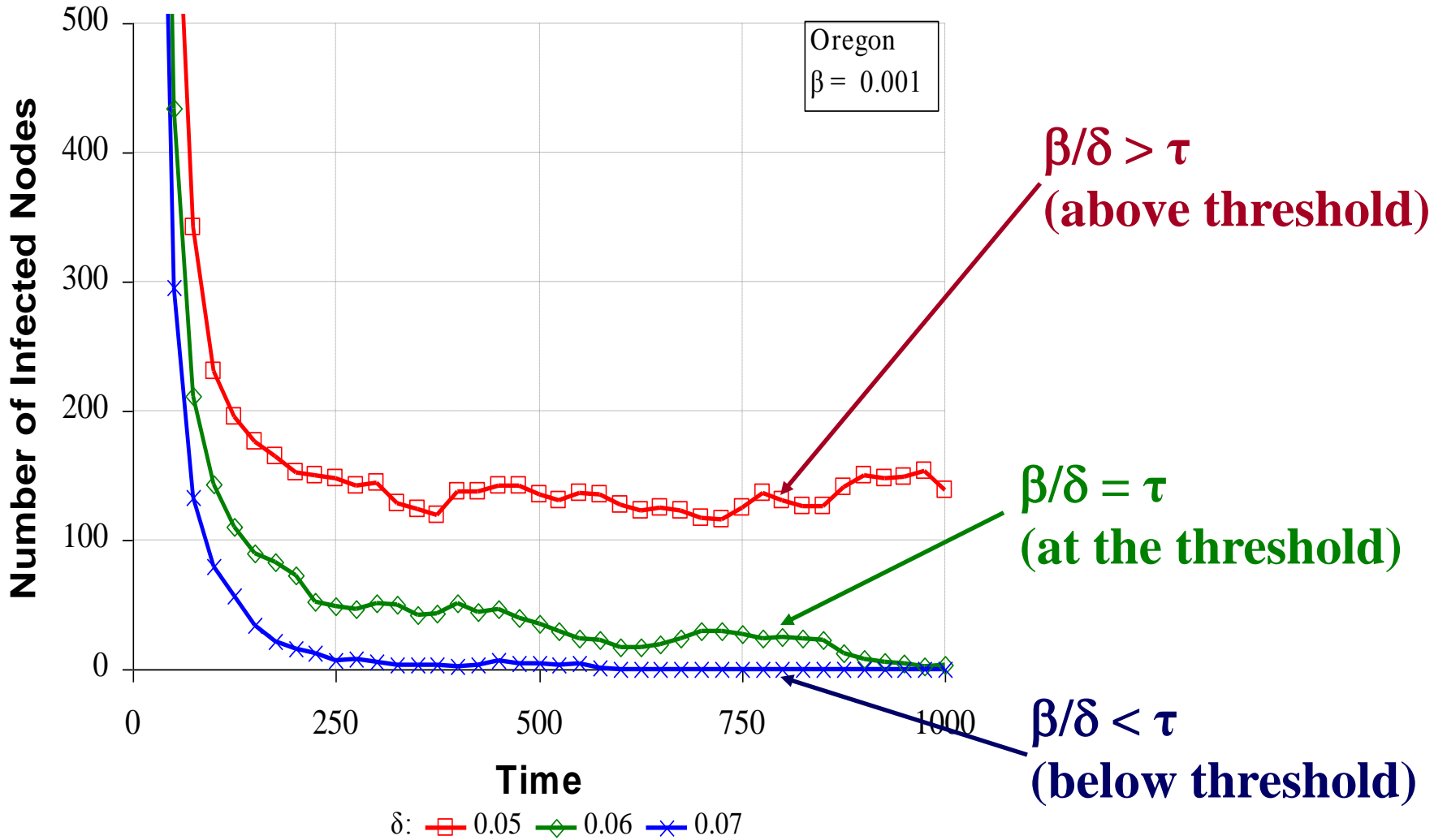



Outline

- Problem definition / Motivation
- Static & dynamic laws; generators
- Tools: CenterPiece graphs; Tensors
- ➔ Other projects (Virus propagation, e-bay fraud detection, blogs)
- Conclusions





E-bay Fraud detection



w/ Polo Chau &
Shashank Pandit, CMU

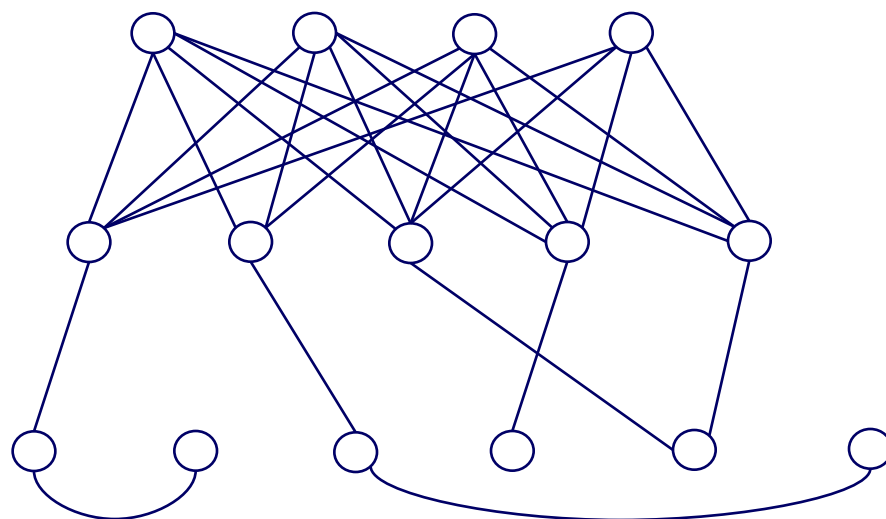



E-bay Fraud detection

- lines: positive feedbacks
- would you buy from him/her?

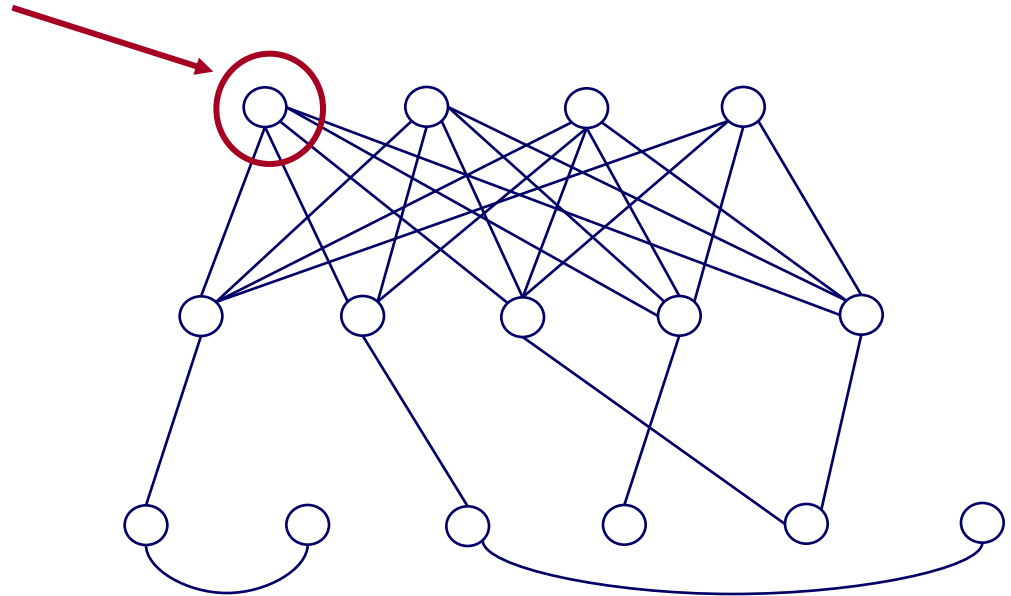



E-bay Fraud detection

- lines: positive feedbacks
- would you buy from him/her?
- or him/her?

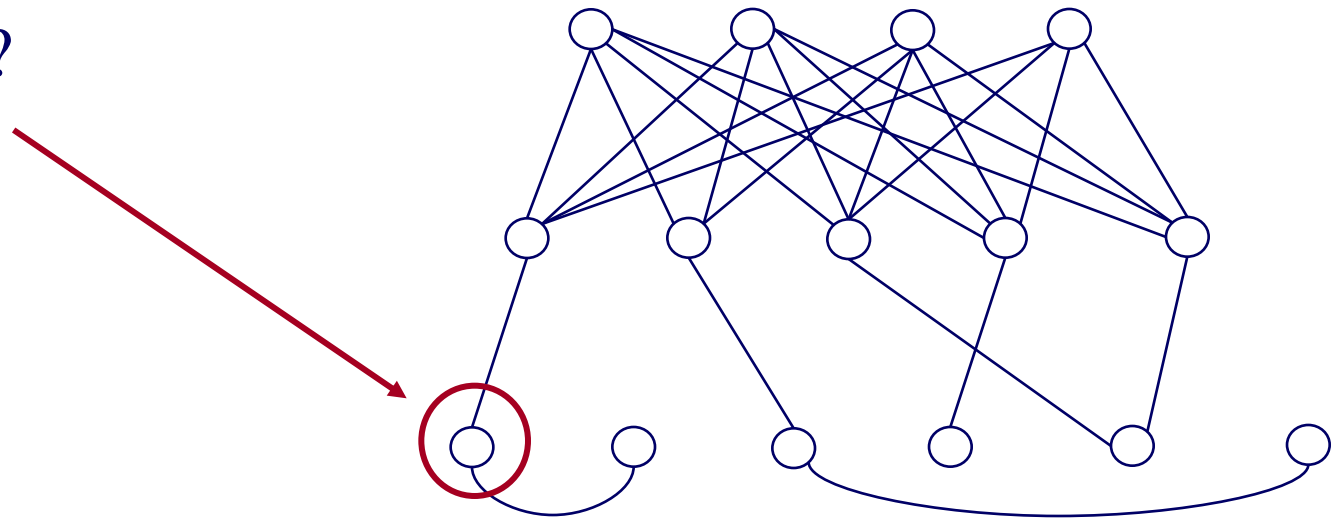



E-bay Fraud detection - NetProbe

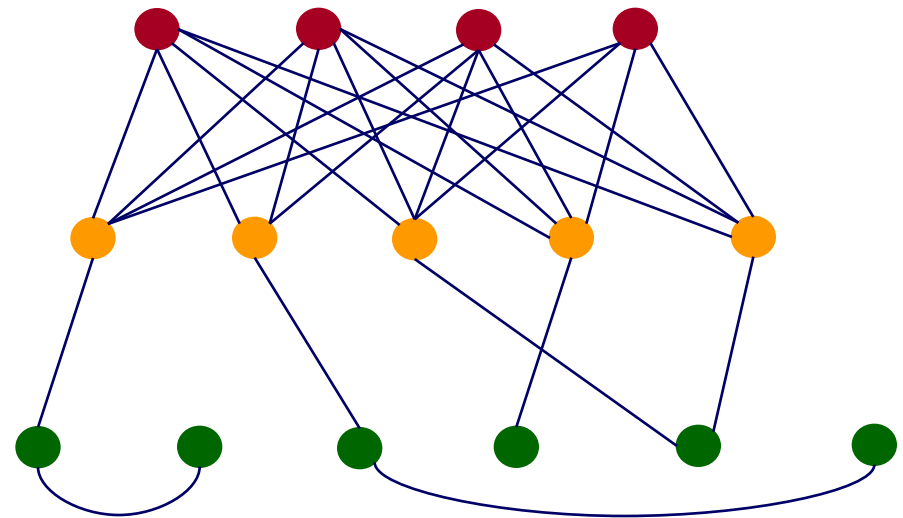
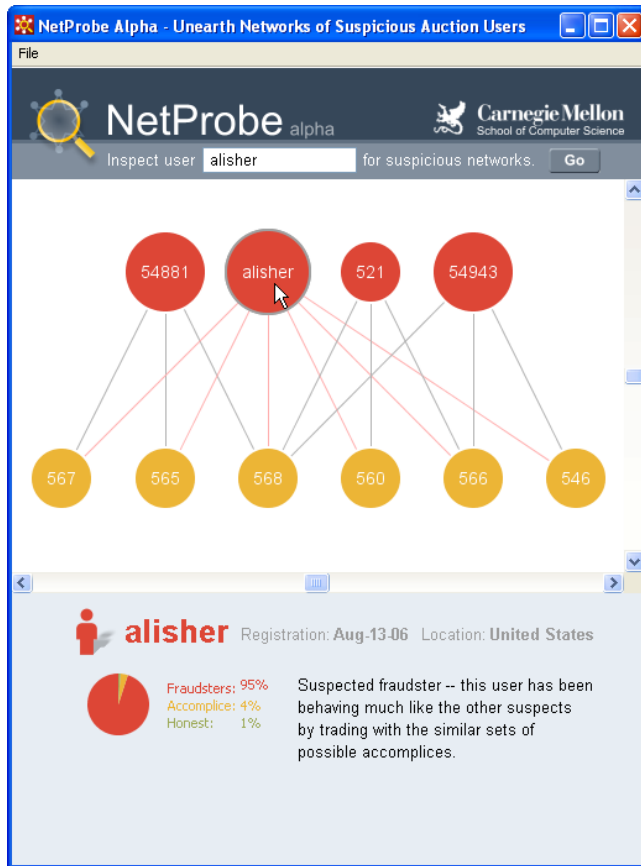



Outline

- Problem definition / Motivation
- Static & dynamic laws; generators
- Tools: CenterPiece graphs; Tensors
- ➔ Other projects (Virus propagation, e-bay fraud detection, blogs)
- Conclusions





Blog analysis

- with Mary McGlohon (CMU)
- Jure Leskovec (CMU)
- Natalie Glance (now at Google)
- Mat Hurst (now at MSR)

[SDM'07]



Cascades on the Blogosphere

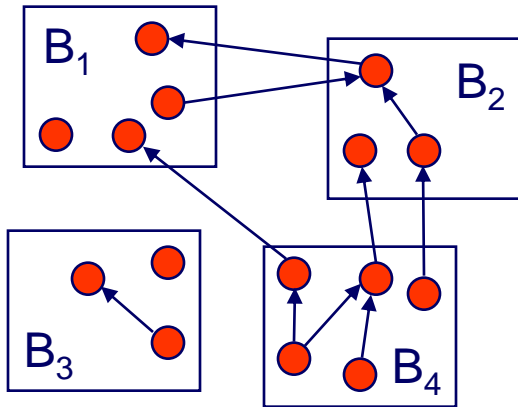

Blogosphere
blogs + posts

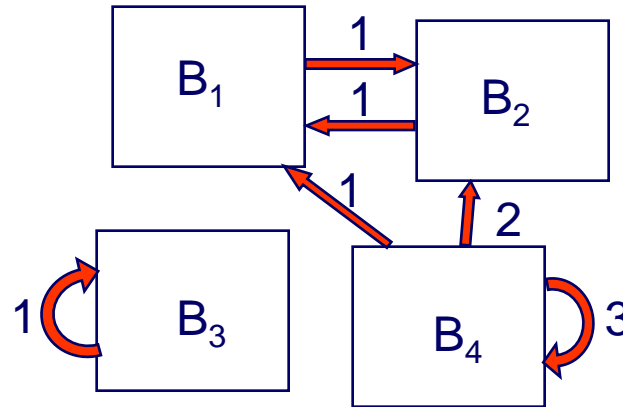

Blog network
links among blogs

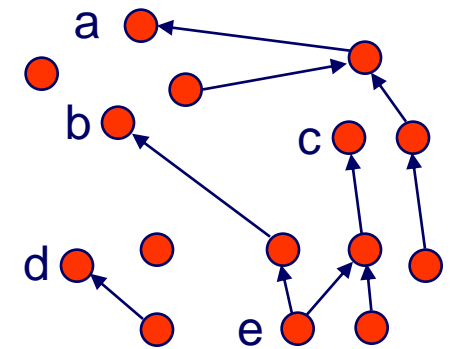

Post network
links among posts

Q1: popularity-decay of a post?

Q2: degree distributions?



Q1: popularity over time

in links

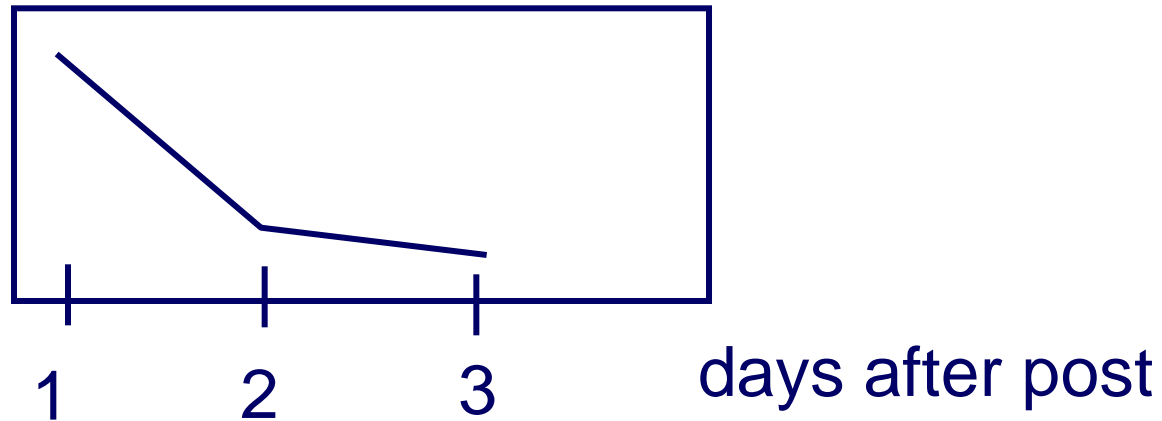

Post popularity drops-off – exponentially?



Q1: popularity over time

in links
(log)

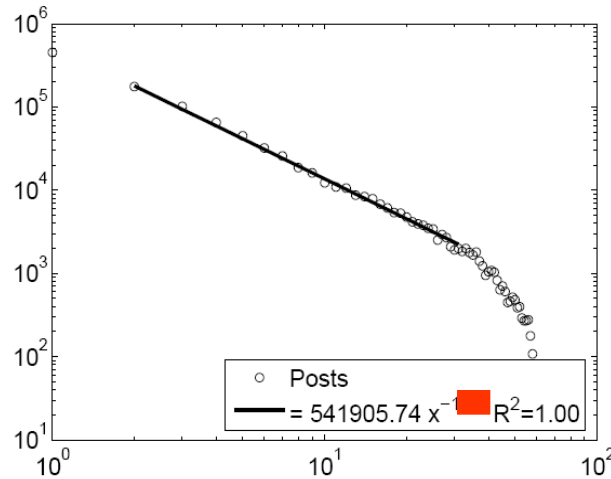

days after post
(log)

Post popularity drops-off – exponentially?



POWER LAW!

Exponent?



Q1: popularity over time

in links
(log)

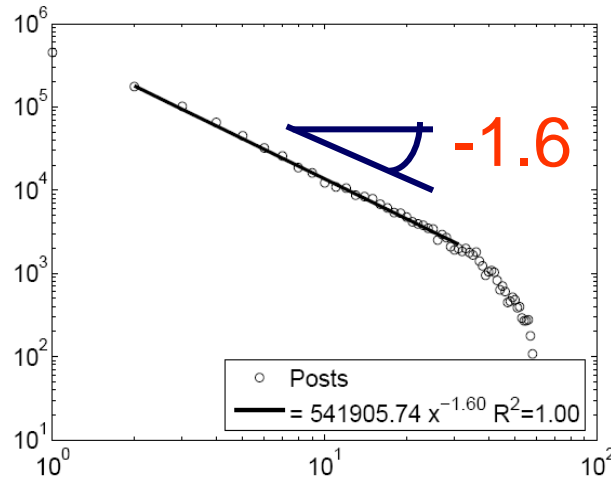

days after post
(log)

Post popularity drops-off – exponentially?

POWER LAW!

Exponent? -1.6 (close to -1.5: Barabasi's stack model)



Q2: degree distribution

44,356 nodes, 122,153 edges. Half of blogs belong to largest connected component.

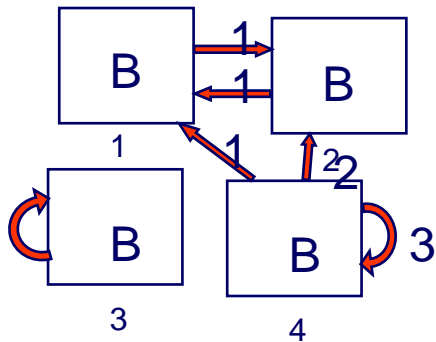

count

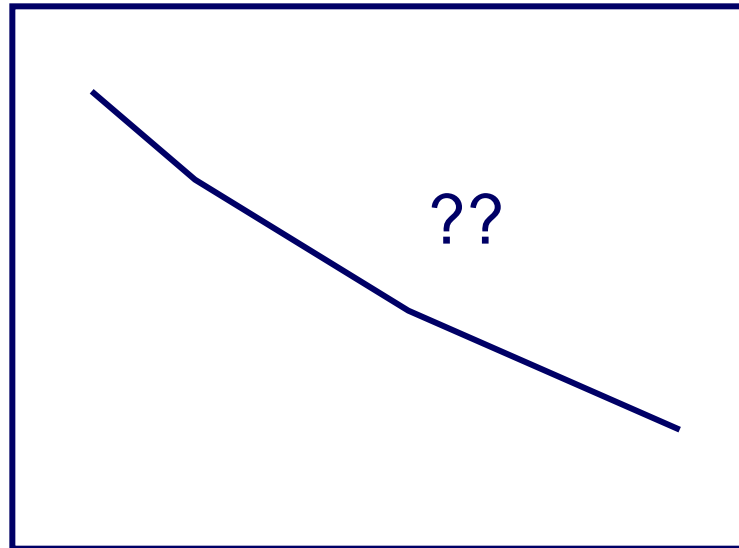

blog in-degree



Q2: degree distribution

44,356 nodes, 122,153 edges. Half of blogs belong to largest connected component.

count

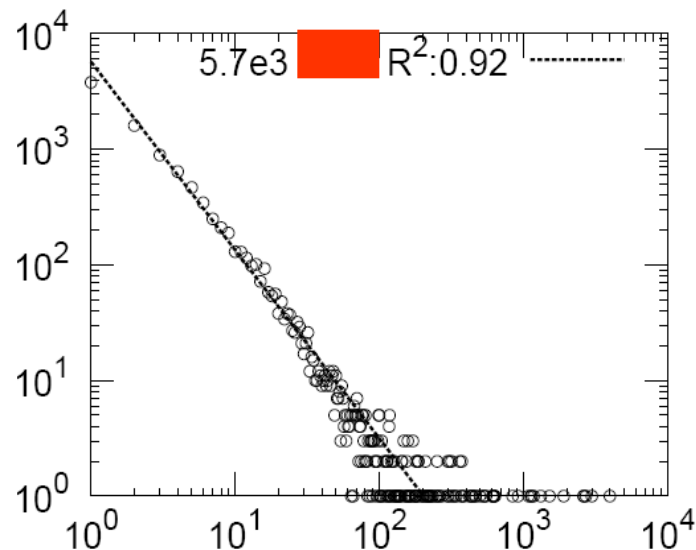
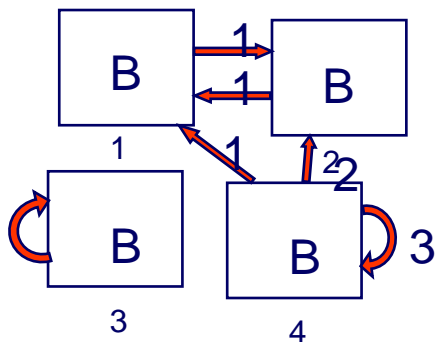

log in-degree



Q2: degree distribution

44,356 nodes, 122,153 edges. Half of blogs belong to largest connected component.

count

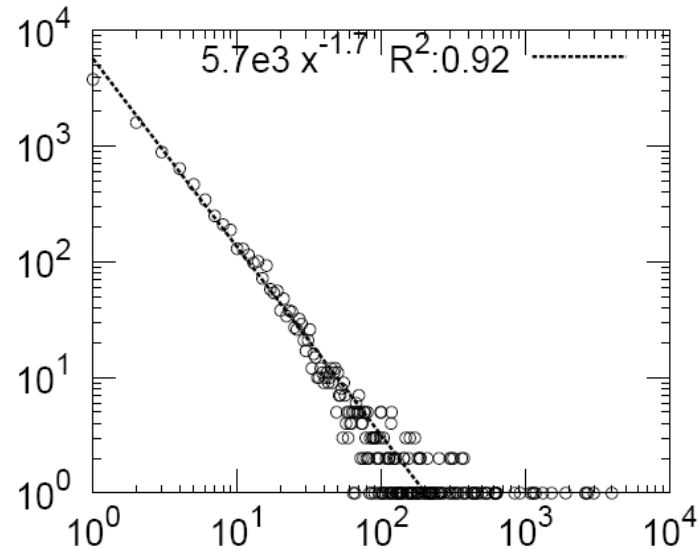

in-degree slope: -1.7

out-degree: -3

‘rich get richer’

log in-degree



Next steps:

- edges with categorical attributes and/or time-stamps
- nodes with attributes
- **scalability** (hadoop – PetaByte scale)
 - first eigenvalue; diameter [done]
 - rest eigenvalues; community detection [to be done]
 - modularity, anomalies etc etc
- visualization (-> summarization)



E.g.: self-* system @ CMU

- >200 nodes
- target: 1 PetaByte





D.I.S.C.



- ‘Data Intensive Scientific Computing’
[R. Bryant, CMU]
 - ‘big data’
 - <http://www.cs.cmu.edu/~bryant/pubdir/cmu-cs-07-128.pdf>



Scalability

- Google: > 450,000 processors in clusters of ~2000 processors each

Barroso, Dean, Hölzle, “Web Search for a Planet: The Google Cluster Architecture”
IEEE Micro 2003

- Yahoo: 5Pb of data [Fayyad, KDD’07]
- Problem: machine failures, on a daily basis
- How to parallelize data mining tasks, then?
- A: map/reduce – hadoop (open-source clone)
<http://hadoop.apache.org/>





2' intro to hadoop

- master-slave architecture; n-way replication (default n=3)
- ‘group by’ of SQL (in parallel, fault-tolerant way)
- e.g, find histogram of word frequency
 - slaves compute local histograms
 - master merges into global histogram

```
select course-id, count(*)  
from ENROLLMENT  
group by course-id
```



2' intro to hadoop

- master-slave architecture; n-way replication (default n=3)
- ‘group by’ of SQL (in parallel, fault-tolerant way)
- e.g, find histogram of word frequency
 - slaves compute local histograms
 - master merges into global histogram

```
select course-id, count(*)  
from ENROLLMENT  
group by course-id
```

reduce

map



OVERALL CONCLUSIONS

- Graphs: Self-similarity and power laws work, when textbook methods fail!
- New patterns (shrinking diameter!)
- New generator: Kronecker
- SVD / tensors / RWR: valuable tools
- hadoop/mapReduce for scalability



References

- Hanghang Tong, Christos Faloutsos, and Jia-Yu Pan *Fast Random Walk with Restart and Its Applications* ICDM 2006, Hong Kong.
- Hanghang Tong, Christos Faloutsos *Center-Piece Subgraphs: Problem Definition and Fast Solutions*, KDD 2006, Philadelphia, PA



References

- Jure Leskovec, Jon Kleinberg and Christos Faloutsos [Graphs over Time: Densification Laws, Shrinking Diameters and Possible Explanations](#) KDD 2005, Chicago, IL. ("Best Research Paper" award).
- Jure Leskovec, Deepayan Chakrabarti, Jon Kleinberg, Christos Faloutsos [Realistic, Mathematically Tractable Graph Generation and Evolution, Using Kronecker Multiplication](#) ([ECML/PKDD 2005](#)), Porto, Portugal, 2005.



References

- Jure Leskovec and Christos Faloutsos, *Scalable Modeling of Real Graphs using Kronecker Multiplication*, ICML 2007, Corvallis, OR, USA
- Shashank Pandit, Duen Horng (Polo) Chau, Samuel Wang and Christos Faloutsos [NetProbe: A Fast and Scalable System for Fraud Detection in Online Auction Networks](#) WWW 2007, Banff, Alberta, Canada, May 8-12, 2007.
- Jimeng Sun, Dacheng Tao, Christos Faloutsos [Beyond Streams and Graphs: Dynamic Tensor Analysis](#), KDD 2006, Philadelphia, PA



References

- Jimeng Sun, Yinglian Xie, Hui Zhang, Christos Faloutsos. *Less is More: Compact Matrix Decomposition for Large Sparse Graphs*, SDM, Minneapolis, Minnesota, Apr 2007. [[pdf](#)]



THANK YOU!

Contact info:

www.cs.cmu.edu/~christos

(w/ papers, datasets, code, etc)