

# Squeezing in a quasi-phase-matched LiNbO<sub>3</sub> waveguide

D. K. Serkland, M. M. Fejer, R. L. Byer, and Y. Yamamoto

Department of Applied Physics, Stanford University, Stanford, California 94305

Received March 27, 1995

We report traveling-wave quadrature squeezing at 1064 nm in a quasi-phase-matched LiNbO<sub>3</sub> waveguide, avoiding the gain-induced diffraction encountered in bulk squeezing experiments. The 10-mm-long single-mode waveguide parametric amplifier exhibited a gain of 1.9, averaged over the 20-ps mode-locked pulses, with only 0.5 W of peak pump power at 532 nm. Independent waveguides were employed for the degenerate parametric amplifier squeezer and for the second-harmonic generator that produced the pump for the parametric amplifier. We measured phase-sensitive amplification versus pump power and found close agreement with theory. The observed 14% squeezing correlates closely with the predicted value, based on the measured phase-sensitive amplification and 40% overall detection efficiency. Impedance-matched electrically resonant detection was used to boost our squeezing measurement signals substantially above the background level.

© 1995 Optical Society of America

Wideband quadrature squeezing from short-pulse-pumped degenerate optical parametric amplifiers has been observed by many researchers since its initial prediction<sup>1</sup> and demonstration<sup>2</sup> eight years ago. All these experiments employed bulk  $\chi^{(2)}$  nonlinear optical crystals and were limited by the phenomenon of gain-induced diffraction, which couples amplified fluctuations into the squeezed quadrature and degrades the squeezing.<sup>3</sup> Waveguides have been proposed and recently employed<sup>4</sup> as a means of avoiding the gain-induced diffraction problem. In this Letter we report 14% squeezing at 1064 nm using a quasi-phase-matched LiNbO<sub>3</sub> (LN) waveguide degenerate parametric amplifier (DPA). The strong nonlinear interaction in our waveguide DPA allowed us to use relatively low pump powers, over an order of magnitude lower than in previous experiments.

According to classical nonlinear optics, a DPA will amplify or deamplify an input signal, depending on its phase relative to the strong (undepleted) pump. For cw fields, this phase-sensitive amplification (PSA) exhibits extrema  $G_{\pm} = \exp(\pm 2\sqrt{\eta P_{\text{pump}}})$ , where the second-harmonic-generation (SHG) efficiency  $\eta$ , defined by  $P_2(L) = \eta P_1^2(0)$ , completely characterizes the nonlinear coupling of the waveguide device. To analyze the PSA resulting from mode-locked pulses, we assume perfect quasi-phase matching and no group-velocity mismatch. Then, in the low-conversion limit, the mode-locked laser pulse  $P_1 = P_{10} \text{sech}^2(t/\tau_1)$  produces a pump pulse  $P_2 = P_{20} \text{sech}^4(t/\tau_1)$ . Averaging over the mode-locked pulses, we predict the DPA to exhibit gain extrema

$$G_{\pm} = \int_{-T/2}^{T/2} \frac{dt}{2\tau_1} \exp[\pm 2\sqrt{\eta_{\text{DPA}} P_{20}} \text{sech}^2(t/\tau_1)] \times \text{sech}^2(t/\tau_1), \quad (1)$$

where  $T$  is the mode-locked pulse repetition period and  $\eta_{\text{DPA}}$  is the efficiency of the DPA waveguide.

We fabricated tens of waveguides by annealed proton exchange on a 1 mm × 6 mm × 10 mm chip of *z*-cut LN, with quasi-phase matching achieved by

Ti indiffusion.<sup>5</sup> Indiffusion at 1050 °C of a 10-nm-thick Ti film grating, made of 1.5- $\mu\text{m}$ -wide lines on a 5.75- $\mu\text{m}$  period, resulted in triangular-shaped inverted domains extending 1.8  $\mu\text{m}$  into the +*z* surface. The 5.75- $\mu\text{m}$  period was selected for first-order quasi-phase matching of the 1064-to-532 nm interaction, with all fields polarized along the *z* axis to exploit the large  $d_{33}$  nonlinear coefficient. Rectangular channels of increased extraordinary index were fabricated by proton exchange through 5.25- $\mu\text{m}$ -wide channel openings in a SiO<sub>2</sub> mask on the LN chip, in a bath of molten benzoic acid at 160 °C. Annealing the LN chip for 3.5 h at 333 °C yielded graded-index channel waveguides<sup>6</sup> that supported a single mode at 1064 nm.

Figure 1 schematically depicts the experimental setup that permitted measurement of PSA and squeezing under nominally identical conditions. A cw mode-locked Nd:YAG laser (Lightwave Electronics Model 131), which produced 20-ps  $\text{sech}^2$  pulses at a 100-MHz repetition rate, provided a desirable combination of high peak power, yielding a strong nonlinear interaction, and low average power, avoiding photorefractive effects in LN. We further reduced the

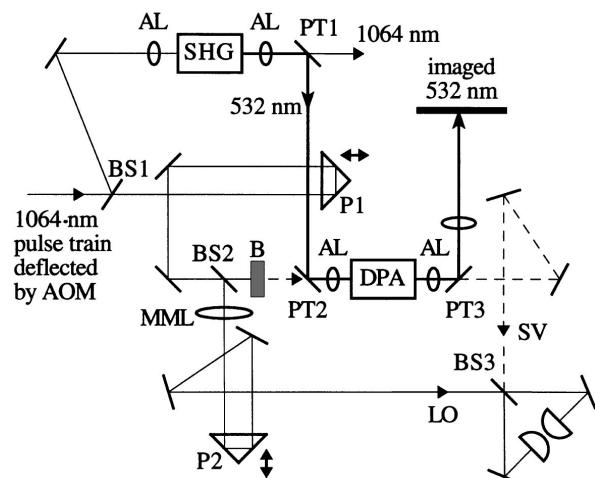

Fig. 1. Schematic of the setup for measuring squeezing and (with minor modifications) PSA.

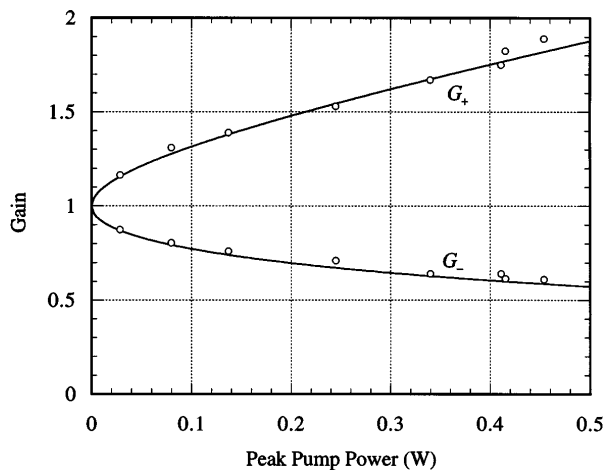

Fig. 2. Gain extrema of PSA versus peak pump power. The solid curve follows Eq. (1).

average power by chopping the laser beam with an acousto-optic modulator (AOM), which deflected a  $6\text{-}\mu\text{s}$  pulse train into the experiment every 2.5 ms.

A waveguide SHG stage ( $\eta_{\text{SHG}} = 0.15 \text{ W}^{-1}$ ) produced 532-nm pulses that pumped a waveguide DPA stage ( $\eta_{\text{DPA}} = 0.4 \text{ W}^{-1}$ ). Both stages consisted of 10-mm-long single-mode waveguide devices with aspheric lenses (AL's) for input and output coupling. Most (90%) of the incident fundamental light went into the SHG stage. Dichroic pump-turning mirrors PT1 and PT2 directed the resultant 532-nm pump beam into the DPA stage. The dichroic mirrors and the dispersion of the aspheric lenses prevented unconverted fundamental light from entering the DPA waveguide. Since the DPA waveguide was necessarily multimoded at 532 nm, we optimized the pump coupling to excite predominantly ( $\approx 90\%$ ) the  $\text{TM}_{00}$  mode, which we verified by imaging the transmitted pump.

To measure PSA we injected a weak signal (to avoid pump depletion) into the DPA, by removing beam block B, and monitored the transmitted power. Dichroic mirror PT3 reflected the pump beam and transmitted the signal, which then passed through a visible-absorbing filter and was focused onto an InGaAs photodiode (not shown in Fig. 1). We measured gain versus signal phase by ramping the voltage applied to a piezoelectric transducer that pushed prism P1 and observed the characteristic oscillation between amplification and deamplification. Figure 2 shows the measured maximum amplification and deamplification versus pump power. The theoretical prediction of Eq. (1) appears as the solid curve in Fig. 2, with no adjustable parameters. Although we have observed gains as high as  $G_+ = 2.5$  at somewhat higher pump powers, heating of the DPA waveguide caused the gain to vary appreciably during the course of the  $6\text{-}\mu\text{s}$  AOM pulse and prevented reliable measurements. We note that at such high pump power levels it is reasonable to expect two-photon absorption of a few percent in the 10-mm waveguide.

The prediction of PSA also applies in the quantum regime, so that if the zero-photon vacuum state enters the DPA, electric-field fluctuations in one quadrature

will be amplified and fluctuations in the other quadrature will be deamplified, or squeezed. Measurement of this squeezed vacuum (SV) requires a balanced homodyne detector, composed of a local oscillator (LO), a 50/50 beam splitter (BS3), and two photodiodes whose currents are subtracted. Good detection efficiency necessitates that the LO be well mode matched to the SV mode after the homodyne beam splitter. We selected the mode-matching lens MML to approximately match the LO to the elliptical waveguide mode. To quantify the mode-matching efficiency, we injected 1064-nm light into the DPA waveguide (with the pump blocked) and optimized the interference with the LO, finding a maximum fringe visibility of  $V = 0.75 \pm 0.03$ .

Figure 3(a) shows an electrical schematic of our resonant radio-frequency balanced detector circuit. We arranged the 1-mm-diameter InGaAs photodiodes (Epitaxx ETX-1000-T) such that the difference current flowed through the inductive load. The inductor and photodiode junction capacitances (60 pF each) formed a tank circuit, resonant at 22.5 MHz, with an impedance-matched quality factor  $Q_m = 8$  limited by the photodiode series resistances ( $7.4 \Omega$  each).

Impedance-matched (resonant) detection enhances the signal by a factor of  $Q_m$ , compared with optimal nonresonant detection. Given two matched photodiodes, each having impedance  $Z_S = R_S + jX_S$ , maximum signal power is delivered to the conjugate matched load  $Z_L = 0.5Z_S^*$ , which is inductive. The power spectral density delivered to the load resistor is  $P_L = S_{\Delta I} R_{\text{eff}}$ , where  $S_{\Delta I}$  is the current spectral density of the difference photocurrent and the impedance-matched value of  $R_{\text{eff}}$  is  $R_{\text{eff},m} = Q_m |X_S|/4$ , with  $Q_m = 0.5|X_S|/R_S$ . For comparison, the optimal nonresonant detector has  $R_{\text{eff}} \approx |X_S|/4$ , which is worse

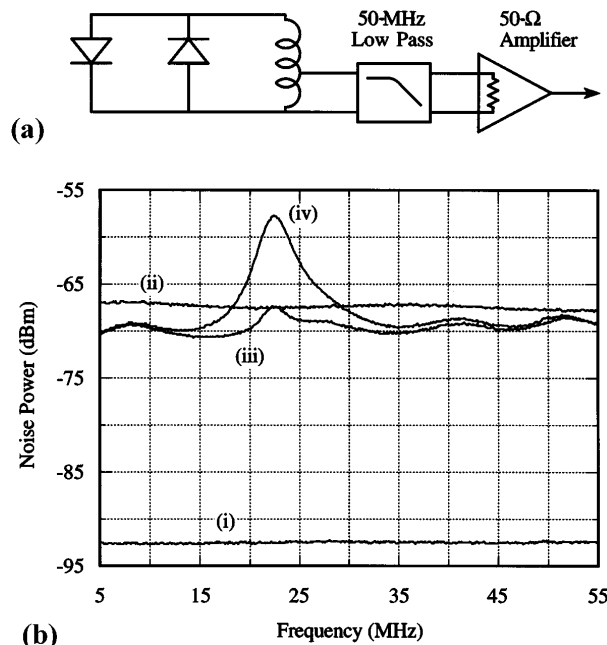

Fig. 3. (a) Electrical schematic of the detector circuit, with the bias circuitry omitted. (b) Spectrum analyzer characterization of the resonant detector, with 1-MHz resolution bandwidth and 100-Hz video bandwidth.

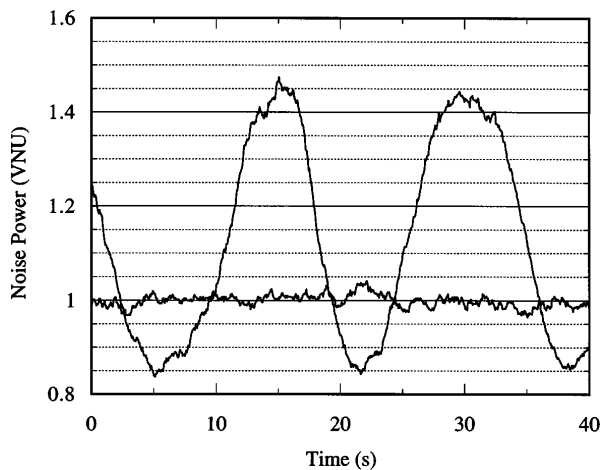

Fig. 4. Squeezed vacuum noise versus time with a linear ramp of the LO phase.

by a factor of  $Q_m$ . We used a tapped inductor to impedance match the photodiodes to our 50- $\Omega$  amplifier. The output of the tapped inductor went through a 50-MHz low-pass filter (MiniCircuits PLP-50) and into a chain to two 50- $\Omega$  amplifiers (Avantek UTC-517), with 22.5-dB gain and 2.0-dB noise figures for each. Our characterization of the resonant detector appears in Fig. 3(b). Trace (i) shows the noise floor of the spectrum analyzer. Trace (ii) shows the noise resulting from a 50- $\Omega$  source resistor at the input of the amplifier chain. Trace (iii) shows the noise obtained from the unilluminated detector, indicating that the detector circuit looked like a 50- $\Omega$  resistor at the resonant frequency. Trace (iv) has added shot noise obtained with 1.0 mW of average LO power (AOM continuously on) incident upon the homodyne beam splitter. We measured 0.366 mA of dc photocurrent through each photodiode, implying an effective quantum efficiency  $\eta_{\text{det}} = 0.85$  (which includes the silver turning mirrors and the detector windows). We theoretically predict, including the amplifier noise figures, that trace (iv) should lie 9.7 dB above trace (iii) at the resonant frequency, which was observed.

When SV at 1064 nm enters the second port of the homodyne beam splitter, as in Fig. 1, the noise peak in Fig. 3(b) should move up and down as the LO phase is swept to sample the antisqueezed and squeezed quadratures. Because the SV noise was measurable only during the 6- $\mu$ s AOM pulses, we employed the gated measurement technique introduced by Aytür and Kumar.<sup>7</sup> We set the spectrum analyzer to measure at 22.5 MHz, with a 1-MHz resolution bandwidth, and fed the video output into a boxcar, integrating over a 4- $\mu$ s gate and averaging over 300 samples. We recorded the boxcar output as a linear ramp was applied to the LO phase. Figure 4 shows our measurement of squeezing, where we have subtracted the amplifier plus thermal noise and normalized to get vacuum-noise units (VNU). The constant-level trace was recorded with the SV port blocked. The oscillating trace was recorded with SV incident upon the homodyne detector and shows the familiar signature of quadrature squeezing, with noise in the squeezed quadrature 14% below the vacuum-state level.

According to theory, the squeezing ratio produced inside the waveguide should be identical to the classical deamplification factor, measured to be 0.62. The discrepancy with the observed squeezing ratio of 0.86 results from losses in the detection process, which degrade the observed squeezing according to  $S_{\text{meas}} = T_{\text{eff}} S_{\text{gen}} + (1 - T_{\text{eff}})$ , where  $S_{\text{gen}} = 0.62$  is the generated squeezing. The detection efficiency is characterized by  $T_{\text{eff}} = T_o V^2 \eta_{\text{det}}$ ,<sup>8</sup> where  $T_o = 0.84$  is the optical transmission from inside the uncoated waveguide to the homodyne detector,  $V = 0.75$  is the fringe visibility, and  $\eta_{\text{det}} = 0.85$  is the detector quantum efficiency. We find that  $T_{\text{eff}} = 0.40$  and thereby predict that  $S_{\text{meas}} = 0.85$ , which is consistent with the observed 0.86.

In summary, we have generated squeezed vacuum with an efficient quasi-phase-matched LiNbO<sub>3</sub> waveguide. The observed 14% noise reduction agrees with the measured parametric deamplification, when one accounts for the 40% detection efficiency. Electrically resonant detection significantly boosted our squeezing signals above the thermal plus amplifier noise background. We predict that approximately 3 dB of squeezing could be observed at 1064 nm if the detection efficiency were improved through spatial mode matching. Perfect spatial mode matching could be achieved by placing a nominally identical waveguide in the LO arm.<sup>9</sup> Substantially higher levels of squeezing will probably require pumping below the two-photon absorption edge, at a wavelength longer than 570 nm.

We thank Lightwave Electronics for loaning us the mode-locked laser and Crystal Technology for donating the LiNbO<sub>3</sub> wafers. D. K. Serkland thanks M. L. Bortz for showing him how to fabricate devices. We are grateful to M. D. Levenson for suggesting resonant detection and to A. J. Alfrey and A. D. Farinas for many helpful discussions. This research was supported by the National Science Foundation.

Y. Yamamoto is also with the ERATO Quantum Fluctuation Project, Research Development Corporation of Japan, and NTT Basic Research Laboratories, Atsugi-shi, Japan.

## References

1. B. Yurke, P. Grangier, R. E. Slusher, and M. J. Potasek, *Phys. Rev. A* **35**, 3586 (1987).
2. R. E. Slusher, P. Grangier, A. LaPorta, B. Yurke, and M. J. Potasek, *Phys. Rev. Lett.* **59**, 2566 (1987).
3. C. Kim, R.-D. Li, and P. Kumar, *Opt. Lett.* **19**, 132 (1994).
4. M. E. Anderson, M. Beck, M. G. Raymer, and J. D. Bierlein, *Opt. Lett.* **20**, 620 (1995).
5. E. J. Lim, M. M. Fejer, R. L. Byer, and W. J. Kozlovsky, *Electron. Lett.* **25**, 731 (1989).
6. M. L. Bortz and M. M. Fejer, *Opt. Lett.* **16**, 1844 (1991).
7. O. Aytür and P. Kumar, *Opt. Lett.* **15**, 390 (1990).
8. L.-A. Wu, M. Xiao, and H. J. Kimble, *J. Opt. Soc. Am. B* **4**, 1465 (1987).
9. P. Kumar, in *Squeezed and Nonclassical Light*, P. Tombesi and E. R. Pike, eds. (Plenum, New York, 1989), p. 175.