



## Teacher Lesson Plan 1 Topography of the Unknown

### Overview

Students will characterize objects that they cannot see. The objects will be placed inside observation boxes, and the students will use height probes to determine the surface height of the objects. After recording the height variations, students will create topographic maps of the objects' surfaces. Using these maps, students will analyze the data and the instrument used to collect the data.

### Time Frame

One or two 45 minute class periods.

### Objectives

Students will

- Create an observation box
- Measure how deep a probe can be inserted into the box
- Determine the relationship between the depth the probe is inserted and the height(s) of the object inside the box.
- Determine the height of the object inside the box at various observation points
- Record the height of the object at each observation point
- Draw a topographic map to show the changes in surface height
- Analyze the topographic map to describe the surface structure
- Critique the instrument (the height probe) and how it is used.

### Materials

*For the Teacher*

- ❑ Scoring Guide for yourself
- ❑ Scoring Guide for each student (optional)
- ❑ Scoring Guide for overhead

*One set of materials per group of 2-3 students:*

- ❑ Observation box: Small shallow cardboard box (approximately 3×3×2) such as a jewelry box
- ❑ Height Probe: Straightened paperclip or thin wooden, plastic or metal stick at least 6 inches long
- ❑ Random objects of different shapes that fit into the box. (if combining with lesson two, objects should attract or repel magnets)
- ❑ Student Guide 1 (one for each student)
- ❑ 3 pieces of scan paper or graph paper
- ❑ Thumbtack
- ❑ Ruler
- ❑ Pen
- ❑ Glue-stick
- ❑ Scissors

*For the class:*

- ❑ Glue Gun
- ❑ Decorating Material - crayons, markers, construction paper, tape, etc. (Optional)
- ❑ Tape



### Vocabulary

**Structure:** the arrangement of particles or parts in an object

**Probe:** any of various testing devices, such as: 1.) *A pointed metal tip for making electrical contact with a circuit element being checked.* 2.) *Usually small object that is inserted into something so as to test conditions at a given point* 3.) *A device used to penetrate or send back information especially from outer space or a celestial body.* 4.) *A device (as an ultrasound generator) or a substance (as DNA genetic research) used to obtain specific information for diagnostic or experimental purposes.*

**Characterization:** the process of determining the properties and/or structure of a material

**Scan:** verb: to examine systematically, point by point with a sensing device.

noun: An image of an object that has been scanned in the above manner.

### Getting Ready:

Decide which **Motivator** you are going to do: Option 1 or Option 2. If doing **Option 1**, make an observation box (with Scan Paper and holes – see procedures) to use as a model with a mystery object inside and a completed scan sheet. (If you have little time to prepare, do the scan sheet with the students to show them how it is completed.) If using **Option 2**, gather probes that students have used in the past or objects that they may recognize as probes. This includes measurement instruments. Also, have a box with an object inside.

When gathering materials, make sure the objects you choose for the observation boxes meet your classes' academic needs. The object(s) that go inside the boxes can be one object or a group of objects. As the height variations in an object increase, the difficulty of the task increases. For students less experienced with rulers, choose simple symmetrical shapes with few height changes. The object can be a matchbox car, tuna can or a ball made from paper with paper clips or magnets taped on the bottom. You may want to have something that will attract or repel a magnet, like a paper clip, bag tie, pen clip, another magnet, etc. taped to the object. In Lesson 2, students use magnet probes to characterize their objects. If the box contains an object that causes a reaction from a magnet, students can characterize the same object. In addition, if students use the same object with both probes, they will have gathered more properties for characterizing the object. Lastly, if you are studying something specific, think about using objects unique to your particular study.

Examples:

Environment: Pinecones, small birds' nests

Geology: Rocks

Pollution: Cans, garbage – things found on the street

Electricity: Different size batteries, conductible vs. not conductible materials

Periodic Table of Elements: Metals and non-metals

You may want extra scan sheets for unforeseen mistakes.

Depending on the students' levels, integrate the height probe component into a lesson on measurement.



### Motivator Choices

#### Option 1: A bit of fiction

*Say: Inside this box, I have a unique object. I can't see it. I can't feel it, yet I want to know something about it. I want to know what it looks like, but if I open the box I will be blinded for life by a piercing light that is triggered by removing the top! (A wonderfully mysterious voice works best – at any age level.)*

Ask the students:

*“If there is an object inside a box, how can you tell the shape of the object?”*

*Show the students the pre-made box with the pierced holes on the top.*

Write the students' responses on the board. Circle the responses that pertain to touching a material, putting a stick through the hole and determining its magnetic properties.

Introduce the term **probe**. Tell the students that scientists use probes to **characterize** matter that we can and cannot see. Here, you may want to digress and discuss probes you have used or discussed in your class. Include in the discussion how the probes have helped you identify properties of objects. In other words, these probes have helped you characterize objects.

Common Probes: Magnifying glass, microscope, litmus paper, ruler, probe used by NASA - space probe, stethoscope

#### Option 2: Probes we know

Place many probes in an area visible to all.

Examples of probes: Magnifying glass, microscope, litmus paper, ruler, stethoscope, balance, scale, picture of a NASA instrument

Ask students to identify all the objects.

Then ask: *What do all these things have in common?* Lead students to the answer that they are all instruments used to determine properties about matter. This is also known as **characterization**. *Say: Doctors try to characterize your heart with a stethoscope. You may have characterized a rock by using a balance and a magnifying glass. The instruments that you used are called instruments but they can also be called **probes**.*

Physically put the probes into two categories: 1) objects that are for things we can see with our naked eye and 2) those we can't see.

Take out a box with an object inside it. Ask the students how we can characterize what is inside the box if we cannot see it. Write the students' responses on the board.

Circle the responses that pertain to touching a material, putting a stick through the hole and determining its magnetic properties

You may want to have students decorate their boxes.

**Making an Observation Box**

***Student Guide 1, Procedures 1-7***

Say: *Today, we are going to use a straightened paper clip (or whatever probe chosen) as a probe to determine the height of an object we cannot see. We are going to put an object into each box and cover it with the top so you cannot see it. Then you will make a scan of its appearance.*

Distribute Student Guide 1. Show the students an example of an observation box or make one with them. Have a student read the procedures as you explain how to complete each step. Explain that the Scan Paper needs to be glued or taped to the top lid and bottom of the box with the letters and numbers in the corner. The top of the box and bottom need to be aligned, so students need to mark the top of the box with a "T." Students can cut the excess paper.

Demonstrate how to safely make the holes on the top cover using a thumbtack. Pierce the center of each square of the Scan Paper that is attached to the lid.

**Preparing the inside of the box**

***Student Guide 1, Procedure 8***

Students should secure an object inside the box with glue or tape. If you want the object to be unknown to the students, collect their observation boxes after they are made. Continue the lesson after you have **securely** placed the mysterious object inside the box with glue or tape. If you are using the same object for Lesson 1 and Lesson 2, make sure the object(s) react with magnets. Also, you may want to tape the box shut so students do not view the object.

**Measuring with the Height Probe**

***Student Guide 1, Procedures 8-10***

Model how to insert the probe into the box. Emphasize the importance of measuring straight down. Either show the students how to measure the height or have them solve the problem and check their work. Discuss different ways to find the height of the object:

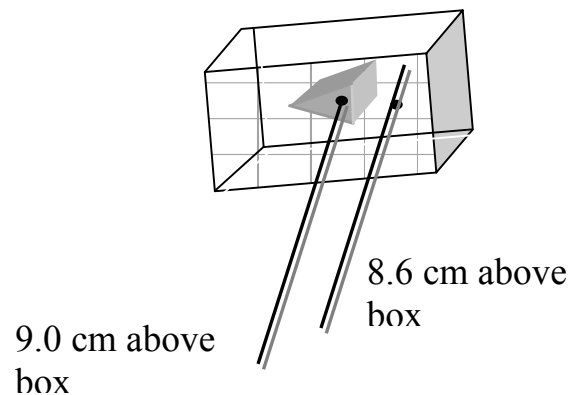

**Steps**

- Insert probe in an area of the box with no object
- Insert probe in an area of the box with the object
- Height of the object at that point is the difference

**Example**

- 8.6 cm of the probe is above the lid
- 9 cm of the probe is above the lid
- $9 - 8.6 = 0.4$  cm is the height of the object at that point

## Probing the Unknown

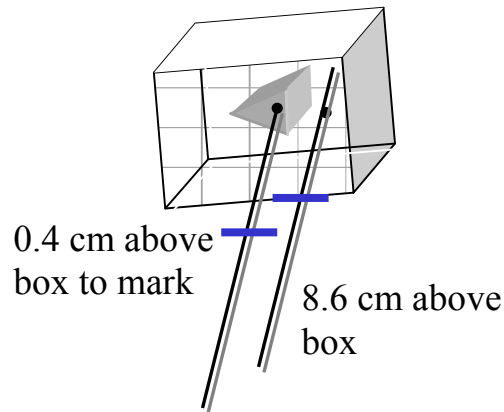

- |  |   |
|--|---|
| <ul style="list-style-type: none"> <li>• Insert probe in an area of the box with no object</li> <li>• Mark the probe where the probe touches the top of box. Use either tape or a permanent marker.</li> <li>• Insert probe in an area of the box with the object</li> <li>• Measure from the top of the box to the bottom of the marker (tape or permanent marker)</li> </ul> | <ul style="list-style-type: none"> <li>• 8.6 cm of the probe is above the lid</li> <li>• 0.4 cm is from the top of the box to the marker</li> </ul> |
|--|---|

### Measuring and Recording with the Height Probe

#### *Student Guide 1, Procedures 9-10*

Once students can use and understand how to measure the height of the object, proceed. Direct students to **systematically** measure and record the height of the object at all probe holes.

When recording the measurements, students should record on the space provided on the student guide or on an additional scan paper. When giving directions, you can analogize data recording to playing Battle Ship. If a student measures 3 cm on the lid, grid A5, they should find A5 on the scan paper, and write 3 cm.

MODIFICATION: Students record their measurements directly on the scan paper that is on the lid. Change the scan paper for each activity or each time the object is changed. Encourage students to write neatly, if you choose to use the same scan paper when using different probes. Otherwise, students may be unable to read their work with so much data on the same paper.

### Making a Topographical Map

#### *Student Guide 1, Procedures 11-12*

You may need to designate the scale students should use for the heights. Decide if you want students to measure and group to the nearest centimeter, nearest  $\frac{1}{2}$  centimeter or millimeter. Although precision is applauded, a greater number of colors will be needed to create the topographical map if there are many heights. In addition, if the probe is not inserted exactly the same into each probe hole, it will be easy for the measurements to vary between a couple of millimeters.



### **Describing the Structure**

#### ***Student Guide 1, Procedure 13***

Students are asked to describe the object's structure on their student guide. This may need to be modeled.

#### **Example**

The center of the object, at 5 cm, is higher than the rest. In the squares directly next to the center, the object's height only slightly dropped. The further we measured from the center, the more the height dropped. Also, it dropped symmetrically out from the center. Because the object's height only dropped slightly, I can infer that the object's surface is sloped slowly. Also the object is the same on all sides since it dropped off the same amount on all sides.

### **Analyzing the Probe**

#### ***Student Guide 1, Procedure 14***

There are many ideas students may have for improving measurements.

Examples:

- Make more probe holes
- Mark the probe in each place that it meets the lid
- Mark the probe just like the centimeter ruler
- Use a straighter probe

### **Conclusion**

1) Gather the students' attention and ask them:

*"What and how did you learn about the materials and shape of the object inside of the box by using the height probe?"*

2) Pick a student from different groups to respond and write the responses on the board.

3) Tell the students that the process they used to determine the shape and type of material used is called characterization. Define characterization: the process of determining the properties and/or structure of material.