

## Nanosecond electro-optical switching with a repetition rate above 20 MHz

Holger Müller,<sup>a)</sup> Sheng-wei Chiow, Sven Herrmann, and Steven Chu

*Physics Department, Stanford University, Varian 226, 382 Via Pueblo Mall, Stanford, California 94305, USA*

(Received 5 October 2007; accepted 12 November 2007; published online 11 December 2007)

We describe an electro-optical switch based on a commercial electro-optic modulator (modified for high-speed operation) and a 340 V pulser having a rise time of 2.2 ns (at 250 V). It can produce arbitrary pulse patterns with an average repetition rate beyond 20 MHz. It uses a grounded-grid triode driven by transmitting power transistors. We discuss variations that enable analog operation, use the step-recovery effect in bipolar transistors, or offer other combinations of output voltage, size, and cost. © 2007 American Institute of Physics. [DOI: 10.1063/1.2822101]

### I. INTRODUCTION

We generate pulses of laser light that can have a duration below 5 ns and a repetition rate in excess of 20 MHz by switching a continuous-wave laser with an electro-optic modulator (EOM). Such pulses allow one to coherently drive atoms into the excited state of a dipole-allowed transition and subsequently observe the decay of the fluorescence when the laser beam is essentially switched off and little stray light can reach the detector. This enables low-noise fluorescence detection of atoms. For example, the  $1/e$  lifetimes  $\Gamma^{-1}$  are 32 ns for Cs at a wavelength of 852 nm and 26 ns for Rb at 780 nm. For coherent excitation of essentially all the population, a flash of light having a duration  $\ll \Gamma^{-1}$  (preferably 5 ns or lower) is required; after an interpulse interval of, e.g.,  $3\Gamma^{-1} \sim 100$  ns, during which the population decays into the ground state, the next pulse can be applied. This implies a repetition rate of 10 MHz.

Our EOM approximates a capacitive load of 15 pF and requires about 250 V input voltage. Nanosecond and even subnanosecond rise times  $t_r$  have been realized with avalanche transistors,<sup>1-4</sup> but the repetition rate is limited to tens or hundreds of kilohertz by average power dissipation and lifetime issues. Metal oxide semiconductor field effect transistors and bipolar transistors of sufficient speed ( $\sim 100$  MHz bandwidth corresponding to  $t_r = 3.5$  ns rise time) are limited to below 100 V;<sup>5</sup> modules consisting of many devices connected in series allow high-voltage operation, with repetition rates limited to tens of kilohertz. A push-pull bipolar design capable of  $t_r = 1$  ns at a repetition rate limited only by this rise time reaches 60 V<sub>p.p.</sub> output.<sup>5</sup> To surpass these limits and meet our requirements, we use a grounded-grid vacuum triode driven by a solid-state differential amplifier stage.

### II. ELECTRONICS

The input stage of the circuit shown in Fig. 1 (IC1, IC2, IC4, IC5) receives transistor-transistor logic (TTL) signals and restores a good square-wave shape. The unused input of IC1b can be used by an overload protection circuit (not shown) to disable the pulser. IC2, IC4, IC5 provide a 5 V<sub>p.p.</sub>

pulse with about 1 ns rise time. ac coupling helps to protect the power stage against excessive duty cycle.

Q1 and Q2 form a differential amplifier. Q1 is biased via D2 and L6, that provide about 5.3 V at the base. Between pulses, Q1 conducts and Q2 is cut off. During a pulse, the current is directed through Q2 and the output tube. As it is regulated by Q4 and IC3A, the output amplitude is precisely constant, without feedback over the output stage. Also, the total current being constant, the inductance of the ground connection is not critical. This helps us to obtain a very good, fast-rise square-shaped output wave form. Q1 can be a low voltage type, which typically leads to high transition frequency. Since the capacities of Q1 and Q4 are not critical, transistors capable of high power dissipation can be chosen. The speed of this driver stage is mainly limited by the output capacity of 35 pF of Q2 (MRF148A), and the tube's input capacity of 30 pF. Inductors L1 and L4 provide series peaking<sup>6</sup> to speed up the signal delivered to the output stage. They are connected to two cathode pins of V5 to control stray inductance. Simulation of this circuit [Fig. 2] shows a 10%–90% rise time of 1.38 ns.

Q2 is mounted upside down on top of Q1 so that both source leads of Q2 can be connected to Q1 to obtain low parasitic inductance  $L_{Q1Q2}$ . For example, just 1 nH would contribute about  $2.2 \times L/R \sim 1.3$  ns to the rise time, where  $R \sim 3$  A/5 V is the impedance of this circuit. The Zener diode D1 protects Q2 against excessive voltage. Oscillations at 250 MHz are suppressed by the capacity of D1, the resistors, and LR combinations in the base leads of the transistors, and the R-C combinations in the emitter lead of Q4.

The pulser is designed with an output impedance of 93  $\Omega$ . Coaxial cables for this are readily available, and the required peak current is reduced to one-half of that required for 50  $\Omega$ . This impedance together with the load capacity sets a lower limit of about  $t_r \sim 2$  ns for the rise time. We will closely approach this theoretical limit.

The tube 3CX800A7 (Ref. 7) (Eimac division of CPI, Inc.) is chosen primarily for its high gain and can deliver up to 8 A of peak anode current. It requires  $\sim 60$  V drive voltage and 0.2 A peak grid current for 300 V output. A special capacitor (Eimac) having low-inductance, large-area contacts

<sup>a)</sup>Electronic mail: holgerm@stanford.edu.

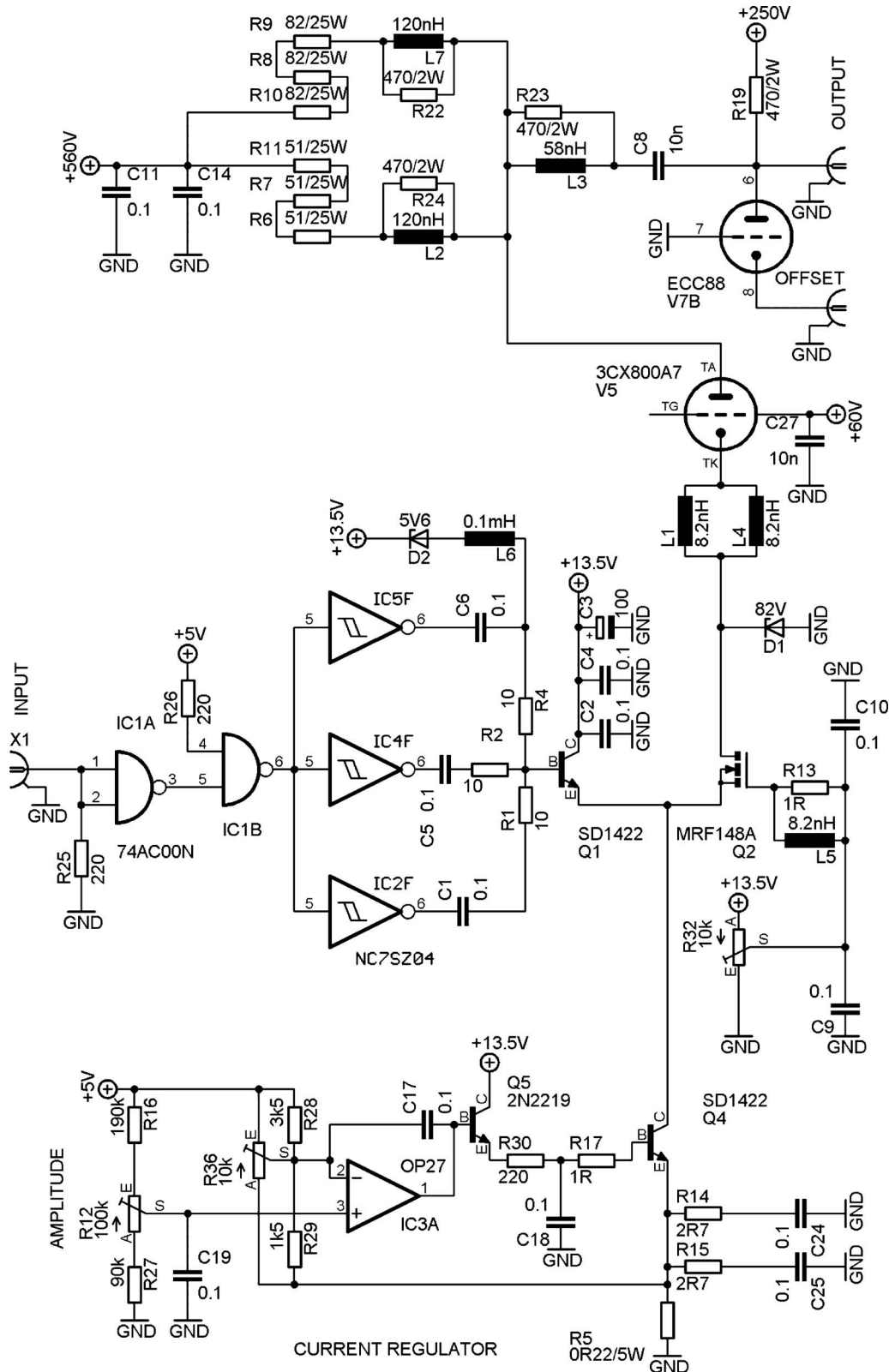

FIG. 1. Schematic.

bypasses the grid to ground. The output signal is ac coupled to the output via C8. V7 is used as a clamp diode to provide a low impedance path for charging C8, thus making the output voltage between pulses very close to zero. Use of a vacuum triode ECC88, connected as a diode, avoids possible pulse distortion associated with the reverse recovery of a

semiconductor diode. To minimize stray capacities, it is soldered directly into the circuit without a socket and its internal shield of V7 is left floating. By removing the ground connection at the offset connector, V7 is cut off and a positive bias of 240 V appears at the output. If desired, a potentiometer or a variable voltage between 0 and 10 V at the

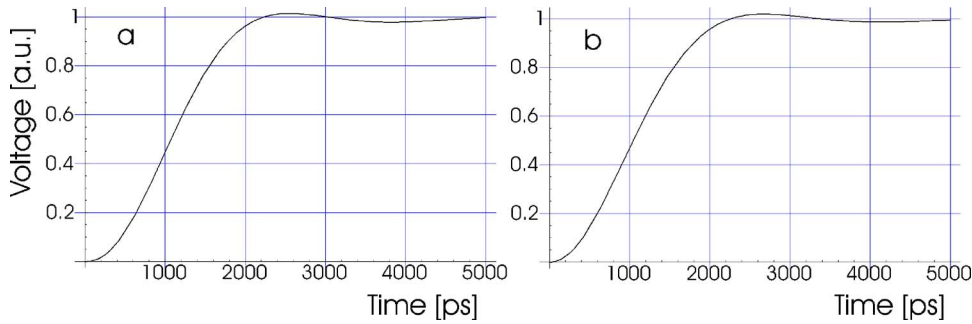

FIG. 2. (Color online) (a) Calculated output pulse for an ideal rectangular drive of V5. (b) Same for V5's input circuit, assuming  $16.6 \Omega$  input resistance and  $12 \text{ nH}$  lead inductance of the tube.

offset connector can be used to vary the dc level at the output between about 5 and 240 V. This can be used for applying slow, continuous signals to the modulator.

R7-R10 are low-inductance types of very compact design (Ohmite TA025PW82R0JE and TA025PW51R0JE), arranged as depicted in the circuit in a way to minimize stray capacities and inductance. Furthermore, the output circuit consists of L2, L7 ( $112 \text{ nH}$  each), and L3 ( $56 \text{ nH}$ ) with paralleled resistors, the output capacity  $C_a=15 \text{ pF}$  of the triode (including circuit strays as measured in our setup), a capacity  $C_d=4.5 \text{ pF}$  of the diode, and a capacity  $C_r=4.5 \text{ pF}$  of the resistors. Simulation shows a rise time of  $1.31 \text{ ns}$  for the output circuit. The combined rise time of the tube's driver and output circuits is thus  $1.90 \text{ ns}$ . Figure 2 shows the calculated response of the output circuit.

The maximum duty cycle  $\eta$  that is permissible for the 3CX800A7 is specified by the "rms current rule," that states that the root mean square (rms) current  $\sqrt{\eta I}$  should not exceed the maximum permissible dc current of  $600 \text{ mA}$ .<sup>7</sup> However, when operating the tube as a class B or C radio frequency amplifier, rms currents 1.6–2 times higher are permissible. Using this as the real limit on the rms current, the permissible duty cycle rises by a factor of 2.7–4. Indeed, the data sheets of some tubes specify duty cycles exceeding the rms current rule (e.g., E130L, 8533, 8906). Thus, operation at about 10% duty should be quite safe. With a minimum pulse duration (limited by the rise time) of below  $4 \text{ ns}$  full width at half maximum, this sets a limit on the repetition rate in excess of  $20 \text{ MHz}$ .

At 10% duty at  $f=20 \text{ MHz}$  and  $3.2 \text{ A}$  peak, the plate of V5 dissipates  $<180 \text{ W}$  including  $\sim 50 \text{ W}$  switching losses assuming  $15 \text{ pF}$  plate capacity. Q2 dissipates about  $26 \text{ W}$ , including  $22 \text{ W}$  switching losses (assuming that the losses when switching on and off are the same), well within the manufacturer's specification of  $115 \text{ W}$ . For Q1 and Q4, losses are  $48 \text{ W}$  (sum of both transistors) almost independent of duty cycle between 0% and 10%.

The output amplitude is determined by the setting of the constant-current source by R12. The transistor capacities and circuit impedances change with peak current which may lead to pulse distortion (overshoot and ringing). To prevent this, the dc grid voltage  $U_g$  of V5 is adjusted between  $20$  and  $75 \text{ V}$  according to the setting of the constant-current source. The optimum is obtained for  $U_g$  such that Q2 is just above saturation.

This leads to a very good square wave form having less than 5% overshoot. At an amplitude of  $250 \text{ V}$ , the rise time

is  $t_r=2.2 \text{ ns}$ . This is what is expected from the  $1.9 \text{ ns}$  theoretical rise time for Q2 and the power stage and  $1 \text{ ns}$  due to the NC7SZ04 inverters ( $\sqrt{1.9^2+1^2}=2.1$ ), but appears too fast in view of additional influences such as Q1's transition frequency. A possible reason for that is that  $L_{Q1Q2}$  provides additional series peaking. At the maximum amplitude of  $340 \text{ V}$ , which is limited by the constant-current source, the rise time increases to  $2.7 \text{ ns}$ , see Fig. 3(a). This may be in part because Q2 is then operated closer to saturation which increases its capacity and does not allow its drain potential to swing as required for series peaking by L1 and L4.

### III. ELECTRO-OPTICAL MODULATOR

The EOM (New Focus model 4102) uses two lithium niobate crystals electrically connected in parallel, which receive signals via an internal  $50 \Omega$  strip line of about  $2.5 \text{ cm}$  length from a (SMA) connector. The total capacity is about  $16 \text{ pF}$ . Directly driving this from a  $Z_0=93 \Omega$  cable,  $t_r \approx 2.2Z_0C \approx 3.3 \text{ ns}$ , even if the pulser output would be infinitely fast. As this would significantly reduce the overall speed, we match the characteristic impedance of the strip line to  $93 \Omega$  by reducing its width. As the crystals are now directly driven from a  $93 \Omega$  source, we only need to consider the crystal capacity of about  $12 \text{ pF}$ . The speed is further enhanced by series peaking<sup>6</sup> with an inductor of  $63 \text{ nH}$  in series to the crystals. The EOM should now show  $t_r \sim 1.8 \text{ ns}$ . With an electrical  $t_r=2.2 \text{ ns}$  of the pulser, we expect an optical  $t_r \approx 0.66 \times \sqrt{2.2^2+1.8^2} \text{ ns} = 1.9 \text{ ns}$ . The factor of 0.66 is the theoretical conversion factor for a Gaussian frequency response and the  $\sin^2$  transfer function of the EOM. This agrees well with the observed optical  $t_r=2 \text{ ns}$ , Fig. 3(b).

### IV. VARIATIONS OF THE CIRCUIT

The circuit can be adapted for analog operation, as a linear amplifier, by driving at the base of Q1. If directly

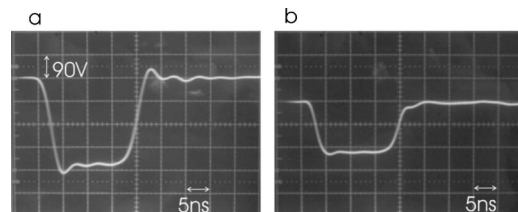

FIG. 3. (a) Electrical output wave form at an electrical amplitude of  $340 \text{ V}$ . (b) Optical wave forms using a New Focus model 4102 EOM driven with about  $250 \text{ V}$  via about  $2 \text{ m}$  of RG-63 coaxial cable.

driven from a  $50\ \Omega$  generator terminated into  $50\ \Omega$ , the speed is limited by the capacitive ( $\sim 70\ \text{pF}$ ) input impedance of Q1 and the finite transition frequency  $f_T$  of Q1, which in connection with the approximately  $1.5\ \Omega$  Ohmic load due to Q2 appears as an additional effective input capacity of  $\sim 100\ \text{pF}$  (assuming  $f_T \sim 1\ \text{GHz}$ ). Thus, the  $R$ - $C$  time constant is 4.2 ns. With a suitable input network, a rise time of 6–8 ns should be possible. It can be improved by reducing the impedance, either by a transformer or by an additional emitter follower.

Using a lower value for R5, the maximum output voltage can be increased to 450 V, limited by the maximum collector current of Q1. Using larger transistors is also possible, especially as Q1's capacity is relatively insignificant. The 3CX800A7 tube enables up to  $\sim 800\ \text{V}$ ; if 300 V output or less suffice, a smaller and cheaper tube may be substituted. Using a E130L (Ref. 8) should lead to similar performance, save for a lower maximum duty cycle.

If the electro-optic crystals and the electronics can be in the same housing, the output impedance can be chosen independently of cable impedances. For a EOM capacity of 12 pF plus 6 pF tube and wiring capacity, with series-shunt peaking, an electrical rise time of 3 ns can be achieved with  $R_2 = 167\ \Omega$ , requiring only 1.5 A peak current. A QQE06/40 tube, that could deliver such current, has an output capacity of 6.4 pF.

A previous version of this circuit used a bipolar  $n$ - $p$ - $n$  2N5642 as Q2. Near the maximum output amplitude of 250 V (lower because of the voltage rating of the 2N5642), the trailing edge became slow, about 5–10 ns. Furthermore

decreasing the grid potential of V5 eventually leads to saturation of the transistor. This increases the pulse duration by a few nanoseconds, as expected because of the minority carrier charge storage in the transistor. However, we accidentally found that it also leads to a *speed up* of the trailing edge. We attribute this to the step recovery effect of the transistor.<sup>9,10</sup> As soon as the stored minority carriers are removed, the transistor switches off rapidly. Thus, rise and fall times of 3.3 and 3.1 ns were achieved. All five tested samples of 2N5642 (made by Advanced Semiconductor) worked satisfactorily.

## ACKNOWLEDGMENTS

This material is based on work supported by the National Science Foundation under Grant No. 0400866, the Air Force Office of Scientific Research, and the Multi-University Research Initiative.

<sup>1</sup>E. S. Fulkerson, D. C. Norman, and R. Booth, 11th IEEE International Pulsed Power Conference, 1997 (unpublished).

<sup>2</sup>W. M. Henebry, Rev. Sci. Instrum. **32**, 1198 (1961).

<sup>3</sup>L. Jinyuan, S. Bing, and C. Zenghu, Rev. Sci. Instrum. **69**, 3066 (1998).

<sup>4</sup>T. P. Rutton, N. Wild, and P. J. Veitch, Rev. Sci. Instrum. **78**, 073108 (2007).

<sup>5</sup>H. Müller, Rev. Sci. Instrum. **76**, 084701 (2005).

<sup>6</sup>R. M. Walker and H. Wallman, in *Vacuum-Tube Amplifiers*, edited by G. E. Valley and H. Wallman (McGraw-Hill, New York, 1948).

<sup>7</sup>3CX800A7 data sheet, Eimac division of CPI, Inc, San Carlos, CA, 1987.

<sup>8</sup>E130L special quality high slope power pentode data sheet (Philips, Eindhoven, 1961) (see, e.g., <http://frank.pocnet.net/index.html>).

<sup>9</sup>R. Paul, *Transistoren* (Vieweg, Braunschweig, 1965).

<sup>10</sup>M. Gerding, T. Musch, and B. Schiek, *Advances in Radio Science* **2**, 7 (2004).