

Motivating example: Babyboot

27.5 Modeling

The figure to the right is a schematic representation of a swinging babyboot attached by a shoelace to a rigid support. The mechanical model of the babyboot consists of a thin uniform rod A attached to a fixed support N by a revolute joint, and a uniform plate B connected to A with a second revolute joint so that B can rotate freely about A 's axis. Note: The revolute joints' axes are *perpendicular*, not parallel.

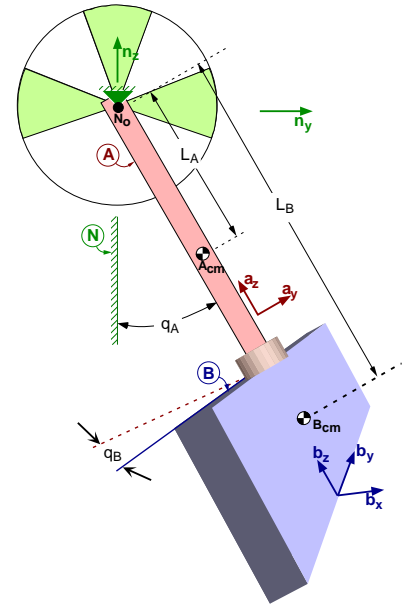

Modeling considerations

- The plate, rod, and support are rigid.
- The revolute joints are frictionless.
- There is no slop or flexibility in the revolute joints.
- The Earth is a Newtonian reference frame.
- Air resistance is negligible.
- The force due to Earth's gravitation is uniform and constant.
- Other distance forces, e.g., electromagnetic and gravitational forces, are negligible.

27.6 Identifiers

Quantity	Symbol	Type	Value
Local gravitational constant		constant	9.81 m/sec ²
Distance between N_o and A_{cm}		constant	7.5 cm
Distance between N_o and B_{cm}		constant	20 cm
Mass of A		constant	0.01 kg
Mass of B		constant	0.1 kg
Central moment of inertia of A for \hat{a}_x		constant	0.05 kg*cm ²
Central moment of inertia of B for \hat{b}_x		constant	2.5 kg*cm ²
Central moment of inertia of B for \hat{b}_y		constant	0.5 kg*cm ²
Central moment of inertia of B for \hat{b}_z		constant	2.0 kg*cm ²
Angle associated with rotation of A in N		dependent variable	varies
Angle associated with rotation of B in A		dependent variable	varies
Time		independent variable	varies

27.7 Physics

The differential equations governing the motion of this mechanical system are

$$\ddot{q}_A = \frac{2\dot{q}_A\dot{q}_B \sin(q_B) \cos(q_B) (I_x^B - I_y^B) - (m^A L_A + m^B L_B) g \sin(q_A)}{I^A + m^A L_A^2 + m^B L_B^2 + I_x^B \cos^2(q_B) + I_y^B \sin^2(q_B)}$$

$$\ddot{q}_B = \frac{-\dot{q}_A^2 \sin(q_B) \cos(q_B) (I_x^B - I_y^B)}{I_z^B}$$

27.8 Simplify and solve

```

Variable qA'', qB'' % Angles and their first and second time-derivatives
%-----
qA'' = 2*( 508.89*sin(qA) - sin(qB)*cos(qB)*qA'*qB' ) / (-21.556 + sin(qB)^2)
qB'' = -sin(qB)*cos(qB)*qA'^2
%-----
Input tFinal=10 sec, integStp=0.02 sec, absError=1.0E-07, relError=1.0E-07
Input qA=90 deg, qB=1.0 deg, qA'=0.0 rad/sec, qB'=0.0 rad/sec
Output t sec, qA degrees, qB degrees
%-----
ODE() solveBabybootODE
Quit

```

27.9 Interpret

The solution to these differential equations is interesting because it reveals that this simple system is capable of strange, non-intuitive motion.⁸ For certain initial values of q_A , the motion of plate B is well-behaved and “stable”. Alternately, for other initial values of q_A , the motion of B is “chaotic,” meaning that a small variation in the initial value of q_B or inaccuracies in numerical integration lead to dramatically different results (these differential equations have been used to test the accuracy of numerical integrators).

For example, the “stable” simulation results in Figure 27.1 correspond to an initial value of $q_A(0)=45^\circ$ together with either $q_B(0)=0.5^\circ$ or $q_B(0)=1.0^\circ$. The “chaotic” simulation results in Figure 27.2 show that q_B is *very* sensitive to initial values. A 0.5° change in the value of $q_B(0)$ results in a more than 2000° difference in the value of $q_B(t=10)$!

The following chart and figure shows the regions of stability (white) and instability (grey) that are associated with this system.

Initial value of q_A	Stability
$0^\circ \leq q_A(0) \leq 71.3^\circ$	stable (white)
$71.4^\circ \leq q_A(0) \leq 111.77^\circ$	unstable (grey)
$111.78^\circ \leq q_A(0) \leq 159.9^\circ$	stable (white)
$160.0^\circ \leq q_A(0) \leq 180.0^\circ$	unstable (grey)

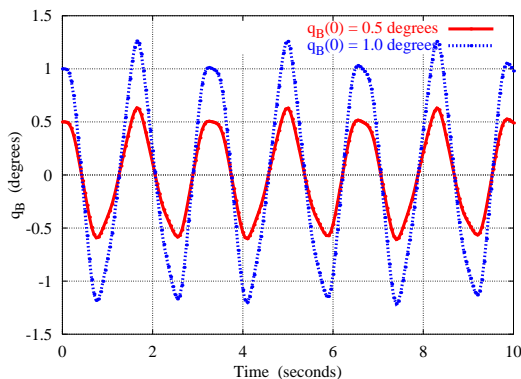
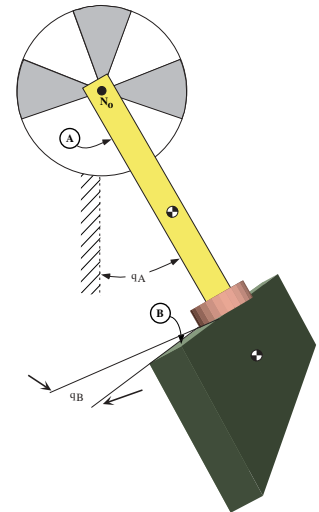

Figure 27.1: Released with $q_A(0)=45^\circ$

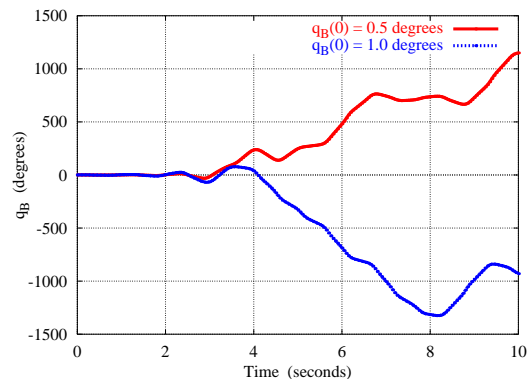

Figure 27.2: Released with $q_A(0)=90^\circ$

⁸More information about this problem can be found in “Mechanical Demonstration of Mathematical Stability and Instability”, International Journal of Engineering Education (also called the Journal of Mechanical Engineering Education), Vol. 2, No. 4, 1974, pp. 45-47, by Thomas R. Kane. The solution to this problem is available by visiting www.autolev.com, selecting Sample Problems, and clicking on Babyboot.

27.10 Physics

```

% File: BabybootWithKanesMethod.txt
% Problem: Analysis of 3D chaotic double pendulum
%-----
SetDigits( 5 )      % Number of digits displayed for numbers
%-----
NewtonianFrame N
RigidBody A        % Upper rod
RigidBody B        % Lower plate
%-----
Variable qA''      % Pendulum angle and its time-derivatives
Variable qB''      % Plate angle and its time-derivative
Constant LA        % Distance from pivot to A's mass center
Constant LB        % Distance from pivot to B's mass center
A.SetMass( mA )
B.SetMass( mB )
A.SetInertia( Acm, IAx, IAY, IAZ )
B.SetInertia( Bcm, IBx, IBy, IBz )
%-----
% Rotational and translational kinematics
A.RotateX( N, qA )
B.RotateZ( A, qB )
Acm.Translate( No, -LA*Az > )
Bcm.Translate( No, -LB*Az > )
%-----
% Forces
g > = -9.81*Nz >
System.AddForceGravity( g > )
%-----
% Equations of motion with Kane's method
SetGeneralizedSpeed( qA', qB' )
Dynamics = System.GetDynamicsKane()
Solve( Dynamics, qA'', qB'' )
%-----
% Kinetic and potential energy
KE = System.GetKineticEnergy()
PE = System.GetForceGravityPotentialEnergy( g >, No )
Energy = KE + PE
%-----
% Integration parameters
Input tFinal=10,      integStp=0.02,      absErr=1.0E-07,      relErr=1.0E-07
%-----
% Input values for constants and initial values for variables
Input LA=7.5 cm,      LB=20 cm,      mA=10 grams,      mB=100 grams
Input IAx=50 g*cm^2,  IBx=2500 g*cm^2,  IBy=500 g*cm^2,  IBz=2000 g*cm^2
Input qA=90 deg,      qA'=0.0 rad/sec,  qB=1.0 deg,      qB'=0.0 rad/sec
%-----
% List quantities to be output by ODE command.
Output t, qA deg, qB deg, Energy N*m
%-----
% C/Matlab/Fortran code or immediate numerical solution to ODEs
ODE() Babyboot
%-----
% Record input together with responses
Save BabybootWithKanesMethod.all
Quit

```

