





Beneficial Designs

research/design/education

Designing beyond the norm to meet the needs of all people.

Peter Axelson

Beneficial Designs, Inc.

Minden, NV



Arroya Sit Ski



Mono Ski



Dynamic Seating Spring Assist

Cross Country Ski



Hand Bike



Adaptive Canoe Seating



Available from
Chosen Valley
Canoe Accessories



Denise Axelson of Beneficial Designs and Mike Passo of Wilderness Inquiry practice and discuss the refinement of measurement protocols before testing begins with the full subject study on the canoe seat development project.

Kathy Mispagel of Beneficial Designs and Mike Passo practice the measurement of maximum lateral stability on the dry land canoe simulator. The angle is measured with a smart level and the tipping is accurately controlled by a vertical extension to the canoe.





Test subjects are coached during the water portion of the evaluation in which the subject finally gets dumped on the count of three to verify safe egress from the canoe. At least one water safety expert is always on hand for this part of the evaluation.



The adjustment of the canoe seating system to adapt to many different makes and models of canoes and to as many different body sizes and shapes is the great benefit of the Universal Canoe Seating system under development by Beneficial Designs.





Lack of Knowledge

All users and land managers need accurate trail data



Objective trail information is very limited, but it enables informed decisions about trail use and conservation

Subjective information is not related to individual abilities



“Moderate” or “Easy”
mean different things
People have different
abilities (young children,

older adults, people with disabilities, unfit and
inexperienced individuals)

Assessment must provide objective
information

Universal Trail Assessment Process - UTAP

Access Information

Construction and Maintenance

Mapping and Interpretation

Environmental Protection and
Management

Compliance with Design Standards



Key UTAP Information

Length



Grade



Width



Surface



Cross
slope



Features &
Facilities



UTAP Assessment Team



Trail Access Information (TAI)

Benefits All

Users know the trail conditions they will encounter

Safety and satisfaction are increased

Land managers can monitor environmental impacts

Maintenance and management needs are documented



UTAP – Implementation Status

Over 800 people trained to lead UTAP assessments

Over 50 trainers to teach UTAP workshops

State and agency-wide implementation is growing (AZ, MN, IN, NY, CA)

UTAP assessments available from consultants

Development Partners

Bureau of Land Management (DOI)

Bureau of Reclamation (DOI)

National Park Service (DOI)

US Army Corps of Engineers

US Fish & Wildlife Service (DOI)

US Forest Service (USDA)

Development Partners

American Trails

California State Parks

Minnesota Department of
Natural Resources

National Center on Accessibility

Wilderness Inquiry

Rotational Penetrometer



Objective surface
measurement device

Draft Standard for
measure of firmness
and stability under
development

Available from
Beneficial Designs

Research Funded by the Access Board

Built 10 trails with different surface types
for human subject testing

Tested 4 user groups using trails

Measured energy expenditure

Established preliminary firmness and
stability requirements for trail surfaces

TrailWare

Computerized data management and analyses

Summarize trail information for users

Summarize trail information for land managers

Export data to Web site and other software



TrailWare Park Data Entry

Park List

Park Info

Trail List

Park Name

Country State/Province/Territory

County(s)

Nearest Town(s)

Address

City Zipcode

Mailing Address

Fees

References

-
-
-

Agency

Region

District

Special Designation(s)

Park Usage Acreage

Season

format : XXX-XXXX

Phone ext

FAX ext

Email

http://

Notes

Delete Park

Add Agency

Help

Exit TW

Blue shading: Fields exported to Trail Explorer or used in Trail Explorer calculations

Yellow shading: Calculated fields, also used in Trail Explorer

Red buttons: Warning - required station data is missing



TrailWare Trail Data Entry

Park List | Park Info | Trail List | **Trail Detail** | Segments | Reports

Trail Name	Pioneer		Trail Designation	National Historic Trail	
Park	Morgan Grist Mill		Agency	Missouri State Parks	
Destination	Old Morgan City		Region	Central	
Dest Type	Historical		District	Cavanaughy County	
Development	Partly	Usage	Medium	Type	Linear
				Age	32
Elevation Maximum	925	Minimum	879	ft	

Delete Trail

Copy to another DB

Help

Exit TW

	Length		Typ	Max	Typ	Max	Tread Width		MCW		Min Vert Obstruction	
	km	mi	Grade %	Grade %	X-Slope %	X-Slope %	cm	in	cm	in	cm	in
Recalc	1.2	0.7	2.4	20	2.3	17	138	54	56	22	15	6

Trail Info: Pioneer Trail goes through a wooded area of Hickory, Maple, and Beech trees. Seasonal wildflowers are abundant in the spring and fall.

Trail Notes: The trail leads to Old Morgan City and Grist Mill.

Trailhead(s)

Activities	Allowed?	Activities	Allowed?	Environmental Zones
Hiking	Yes			Forest
Dogs - On Leash	Yes			
Bicycling	Yes			
Equestrian	No			
Motor Vehicles	No			

Blue shading: Fields exported to Trail Explorer or used in Trail Explorer calculations
 Yellow shading: Calculated fields, also used in Trail Explorer
 Red buttons: Warning - required station data is missing



TrailWare Segment Data Entry

Park List | Park Info | Trail List | Trail Detail | Segments | **Segment Cover** | Stations | Features | Reports

Trail Name	Pioneer		Assessment Date (mm/dd/yyyy)	4/22/02
Segment	1	1 Seg Pioneer to Mill	Team Coordinator	Z. Sleeper
Weather Conditions at time of assessment	Dry, humid		Certification #	123456789
Temperature at time of assessment	Low Temp	High Temp	Data Recorder	Z. Sleeper
	84	92 F	Stations	Mia Surement
	Date	Amount	Distance	Mia Surement
Most Recent Rainfall	6/30/01	.25 in	Typ Tread Width	D. Hite
	Start	End	Typ Cross Slope	I. Slope
Elevation Data (ft/m)	899	879	Surface	Z. Sleeper
	Minimum	Maximum	Typical Grade	T. Grader
	879	925 ft	Direction	D. Rector
			Max Cross Slope	I. Slope
			Max Grade	I. Slope
			Min Clearance	D. Hite

Assessment Data Units and Standards

Length Units used	Slope Units used	Design Tread Width	Design Height
Distance	Typ X-Slope	<input type="radio"/> 36 in (0.9 m)	<input checked="" type="radio"/> 84 in (2.1 m)
Tread Width	Typ Grade	<input checked="" type="radio"/> 60 in (1.5 m)	<input type="radio"/> 96 in (2.4 m)
X-Slope Max	X-Slope Max	<input type="radio"/> 120 in (3 m)	<input type="radio"/> 120 in (3 m)
Grade Max	Grade Max	Other	Other
MCW	X-Slope in/out (+/-) recorded?	Minimum Obstruction Height	Minimum MCW Height
	<input checked="" type="radio"/> yes	<input type="radio"/> 0.5 in (2.5 cm)	<input type="radio"/> 0.5 in (2.5 cm)
<input checked="" type="radio"/> Compass bearings	<input type="radio"/> GPS coordinates	<input checked="" type="radio"/> 2.0 in (5.0 cm)	<input checked="" type="radio"/> 2.0 in (5.0 cm)
Compass		<input type="radio"/> 3.0 in (7.5 cm)	<input type="radio"/> 3.0 in (7.5 cm)
Declination	Format: dd mm.m D	<input type="radio"/> 6.0 in (15 cm)	<input type="radio"/> 6.0 in (15 cm)
	d=degrees, m=minutes to one decimal, D=Direction (E or W)	Other	Other

Data Form Option Old Current

Station Entry Basic Extended
 Tabbing Options

Extended option tabs through all fields on station entry form. Basic option tabs through left side only (including compass measurements if checked).

Omit Stairs or Ladders Yes

If this is checked, then stations noted of surface type Stairs or Ladders will not be included in the typical grade calculation

Rotational Penetrometer Readings

Surface Type	firmness		stability	
	wet	dry	wet	dry

- Delete
- Copy to Another Trail
- Duplicate within Trail
- Reverse
- Split
- Help
- Exit TW

Blue shading: Fields exported to Trail Explorer or used in Trail Explorer calculations
 Yellow shading: Calculated fields, also used in Trail Explorer
 Red buttons: Warning - required station data is missing



TrailWare Station Data Entry

Warning, required station data missing

Park List | Park Info | Trail List | Trail Detail | Segments | Segment Cover | **Stations** | Features | Reports

Trail Name Segment Name Date

Station	Distance	in	pct		pct		pct	ft	pct	ft	in	Re-order
	Distance	Tread Width	X-Slope	Surface Category	Type	+/- Grade	Typ	Compass Fwd	Back	Max X-Slope Magnitude	Max Grade Length	MCW
0	60	60	1.9	Firm	Soil	1.5		132	131			
35	60	60	2.1	Firm	Soil	1.0		146	147			
112	60	60	1.6	Firm	Soil	1.5		150	151	6.8	8	
149	60	60	1.4	Firm	Soil	0.0		150	150		9.1	
227	55	55	1.8	Firm	Soil	-1.0		141	142			
318	55	55	2.3	Firm	Soil	-1.5		127	127			

Add Station
Finish Entry
Help
Exit TW

2264 Final Distance

Blue shading: Fields exported to Trail Explorer or used in Trail Explorer calculations
 Yellow shading: Calculated fields, also used in Trail Explorer
 Red buttons: Warning - required station data is missing



TrailWare Feature Data Entry

Required feature data omitted

Help

Exit TW

Park List | Park Info | Trail List | Trail Detail | Segments | Segment Cover | Stations | **Features** | Reports

Trail Name Segment Name Date

Feature Distance	T/V Zone	Feature Type	Feature Description	Size			U/M	Count/ Qty	End Distance	Remain Tread	Built		Action Required	Materials	!! Add Info			
				L	W	H					Feature Access	Action						
0	T	Trailhead	Parking Lot												<input type="radio"/>	<input type="radio"/>	<input type="button" value="go"/>	<input type="button" value="trash"/>
0	V	Restroom	Chemical Toilet					1				Yes			<input type="radio"/>	<input type="radio"/>	<input type="button" value="go"/>	<input type="button" value="trash"/>
47	V	Picnic Table	Wooden					2							<input type="radio"/>	<input type="radio"/>	<input type="button" value="go"/>	<input type="button" value="trash"/>
53	V	Scenic Viewpoint	Mt. Cora						149						<input type="radio"/>	<input type="radio"/>	<input type="button" value="go"/>	<input type="button" value="trash"/>
69	T	Root	Multiple Roots	14	5	6	in	5	83	38					<input type="radio"/>	<input type="radio"/>	<input type="button" value="go"/>	<input type="button" value="trash"/>
130	V	Bench	Back and armrests	60	18	18	in	1							<input type="radio"/>	<input type="radio"/>	<input type="button" value="go"/>	<input type="button" value="trash"/>
199	T	Rock	Small Boulder	13	12	16	in	1		48			Remove		<input type="radio"/>	<input type="radio"/>	<input type="button" value="go"/>	<input type="button" value="trash"/>
239	V	Bench	Back and armrests	60	18	18	in	1							<input type="radio"/>	<input type="radio"/>	<input type="button" value="go"/>	<input type="button" value="trash"/>
334	T	Waterbar	4 X 4 Plank	4	54	8		1		0					<input checked="" type="radio"/>	<input type="radio"/>	<input type="button" value="go"/>	<input type="button" value="trash"/>
338	T	Erosion	Center of Trail	10	8	12	in						Monitor		<input type="radio"/>	<input type="radio"/>	<input type="button" value="go"/>	<input type="button" value="trash"/>
416	T	Minimum Clearance	Boulder- large, centered in path	40	22	20	in						Remove		<input type="radio"/>	<input type="radio"/>	<input type="button" value="go"/>	<input type="button" value="trash"/>
521	V	Bench	Back only	60	18	18	in	1							<input type="radio"/>	<input type="radio"/>	<input type="button" value="go"/>	<input type="button" value="trash"/>

Blue shading: Fields exported to Trail Explorer or used in Trail Explorer calculations

Yellow shading: Calculated fields, also used in Trail Explorer

Red buttons: Warning - required station data is missing

Driveway Data Collection Form

Date _____ Data Recorder _____

DRIVEWAY LOCATION

Street Name _____ Side of Street N S W E _____
 Nearest Cross Street(s) _____
 GPS Coordinates _____ N/S E/W Adjacent Property Description _____

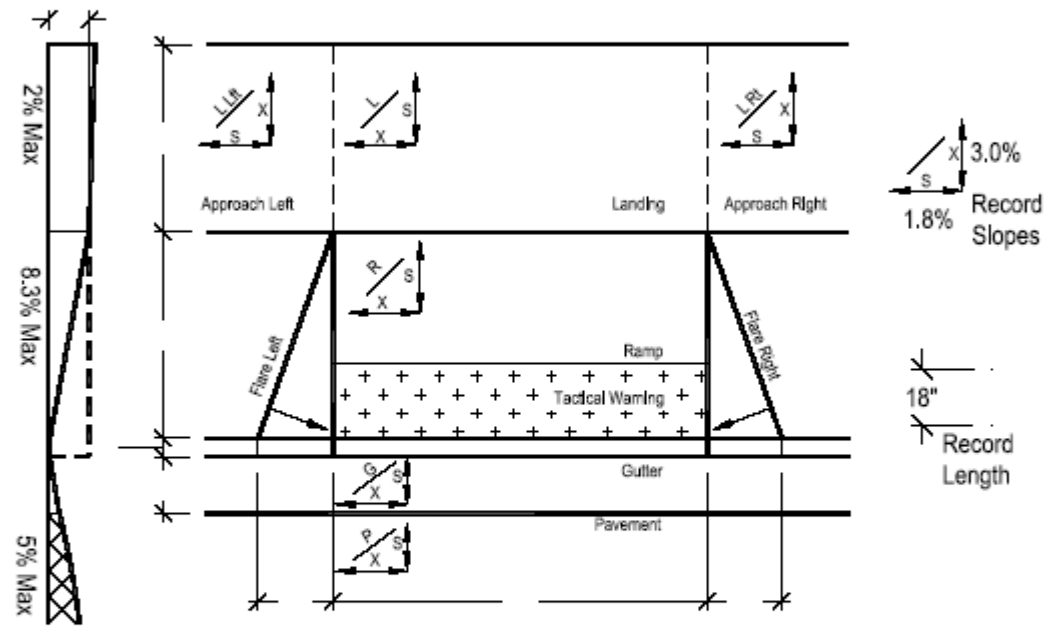

DRIVEWAY CHARACTERISTICS/SIDEWALK ELEMENTS

Include all sidewalk elements (i.e. utility pole, sign, etc.) on the drawing to indicate their position.
 Digital Image taken – frame # and description _____

Record any surface height transitions over 0.25 inches using a profile gauge.
 Trace the transition on the back of this form, then indicate the location on drawing.

- | | | |
|--|---------------------------------------|---|
| Driveway Type: | Surface Material Type: | Recommended Action: |
| <input type="checkbox"/> Offset Sidewalk | <input type="checkbox"/> Asphalt | <input type="checkbox"/> Repair <input type="checkbox"/> Construct |
| <input type="checkbox"/> Parallel Approach | <input type="checkbox"/> Concrete | <input type="checkbox"/> Reconstruct <input type="checkbox"/> Monitor |
| | <input type="checkbox"/> Other: _____ | <input type="checkbox"/> Other: _____ |

Curb Ramp Data Collection Form

Date _____ Data Recorder _____

CURB RAMP LOCATION

Street Name _____	Side of Street	N	S	W	E
Nearest Cross Street(s) _____	Indicate Corner of Intersection	NW	NE	SW	SE
GPS Coordinates _____	N/S	E/W	Adjacent Property Description _____		

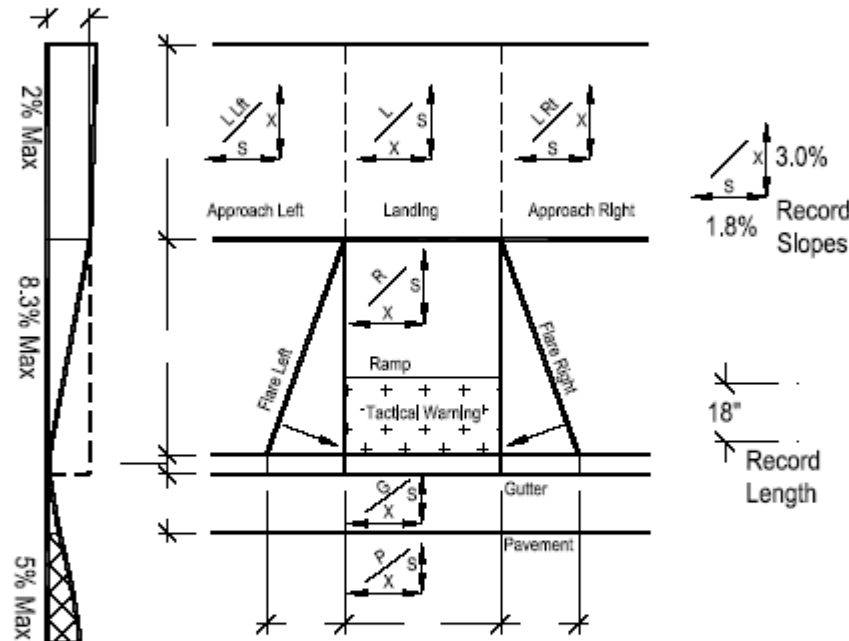

CURB RAMP CHARACTERISTICS/SIDEWALK ELEMENTS

Include all sidewalk elements (i.e. utility pole, sign, etc.) on the drawing to indicate their position.

Digital Image taken – frame # and description _____

Record any surface height transitions over 0.25 inches using a profile gauge. Trace the transition on the back of this form, then indicate the location on drawing.

Curb Ramp Type:	Surface Material Type:	Recommended Action:
<input type="checkbox"/> Diagonal	<input type="checkbox"/> Asphalt	<input type="checkbox"/> Repair
<input type="checkbox"/> Perpendicular	<input type="checkbox"/> Concrete	<input type="checkbox"/> Reconstruct
	<input type="checkbox"/> Other: _____	<input type="checkbox"/> Construct
		<input type="checkbox"/> Monitor
		<input type="checkbox"/> Other: _____

TrailWare Reports

English or Metric units

Data summaries:

Grade, Cross Slope and Width

Surface Category and Type

Tread and Vertical Obstructions

Trail Access Information

Station or Feature Log Report

Pioneer

Print
w/Notes

Print
no Notes

Export

Reports

Morgan Grist Mill

Feature Log (to sort by column, click on underlined headings)

Seg	<u>Feature</u> Distance	<u>TV</u> Zone	<u>Feature Type</u>	<u>Feature Description</u>	<u>L</u> x <u>W</u> x <u>H</u>	UM	Count	End Distance	<u>Remain</u> Tread	<u>Built</u> Feature	<u>Action</u> Required	<u>Materials</u>	Photo?
2	1664	V	Waterfall	Grist Mill Waterfall									<input type="checkbox"/> <input type="radio"/>
1	334	T	Waterbar	4 X 4 Plank	4	54	8		1	0			<input type="checkbox"/> <input checked="" type="radio"/>
1	891	T	Waterbar		4	50	6	in	1	0			<input type="checkbox"/> <input type="radio"/>
1	2077	V	Water	Drinking Fountain					2	Yes			<input type="checkbox"/> <input type="radio"/>
1	1496	T	Vertical	Branches	36	60	48	in	1501	0	Remove		<input type="checkbox"/> <input type="radio"/>
2	1453	T	Vertical	Branches	43	48	6	in	1457	0	Clear		<input type="checkbox"/> <input type="radio"/>
2	1457	T	Vertical	Overhanging Rock	57	46	73	in	1463	20			<input type="checkbox"/> <input type="radio"/>
1	1478	V	Tree	Old Hickory Grove						1509			<input type="checkbox"/> <input type="radio"/>
2	236	V	Tree	Oak Tree Grove						293			<input type="checkbox"/> <input type="radio"/>

Summary Tables for Typicalals

Pioneer Morgan Grist Mill Grade Percentages

first segment assessed Apr 22, 2002

last segment assessed Apr 22, 2002

Grade %	% of trail	Length		Sum % of trail	
		m	km		
0-3	63.9%	765.0	0.77	>=0	100.0%
3.1-5	25.1%	300.8	0.30	>3	36.1%
5.1-8	7.0%	83.5	0.08	>5	11.0%
8.1-10	0.9%	11.3	0.01	>8	4.0%
10.1-12	0.9%	10.4	0.01	>10	3.1%
12.1-14	0.7%	8.8	0.01	>12	2.2%
14.1-16	0.7%	8.2	0.01	>14	1.5%
16.1-20	0.8%	9.1	0.01	>16	0.8%
20.1-30	0.0%	0.0	0.00	>20	0.0%
30.1-50	0.0%	0.0	0.00	>30	0.0%
over 50	0.0%	0.0	0.00	>50	0.0%
Total	100.0%	1197.2	1.20		

Extreme Summary Tables

**Pioneer
Morgan Grist Mill
Maximum Grade Percentages**

First Segment Assessed Apr 22, 02

Last Segment Assessed May 7, 02

Grade %	Length ft	Location ft	mi	Cumulative Length (ft) and Grade
19.4 %	8.00	2264.0	0.43	
				8.0 >= 19.4 %
18.6 %	5.00	2307.0	0.44	
				13.0 >= 18.6 %
16.5 %	7.00	3127.0	0.59	
				20.0 >= 16.5 %
-16.3 %	10.00	3668.0	0.69	
				30.0 >= 16.3 %
15.4 %	6.00	2350.0	0.45	
				36.0 >= 15.4 %
15.3 %	6.00	3346.0	0.63	
				42.0 >= 15.3 %
14.1 %	15.00	433.0	0.08	
				57.0 >= 14.1 %
13.2 %	11.00	517.0	0.10	
				68.0 >= 13.2 %

TrailWare Calculations

Typical and extreme values for
Grade, Cross Slope and Width
Surface Category and Type
Tread and Vertical Obstructions

TAI Summary

Pioneer

Morgan Grist Mill

Trail Access Information Summary

page 1
first segment assessed Apr 22, 2002
last segment assessed May 7, 2002

Trail Length 0.7 mi (1.2 km)

Linear trail

Cumulative Elevation Change

Gain 61 ft (19 m)

Loss 32 ft (10 m)

Typical Grade is 2.4%

4% of the trail is between 8% and 20%

86 ft (26 m) is between 12% and 20%

8% grade is a standard ramp.

Locations and lengths can be found on the Maximum Grade Table Reports

Typical Cross Slope is 2.3%

1% of the trail is between 8% and 17%

39 ft (12 m) is between 10% and 17%

Locations and lengths can be found on the Maximum X-Slope Table Reports

Typical Tread Width is 54 in (138 cm)

Tread Width ranges from 45 in (114 cm) to 60 in (152 cm)

Minimum Clearance is 22 in (56 cm)

Locations and lengths can be found on the Minimum Tread Width Table and Minimum Clearance Width Report

Trail Surface is Soil

87% of the trail is Firm or better

525 ft (160 m) of the trail is Soft or worse

Locations and lengths can be found on the Surface Category Table Reports

Obstructions

Minimum Vertical Obstruction is 6 in (15 cm)

Locations and lengths can be found on the Minimum Vertical Obstructions Reports

Dropoff

Vertical

Steps

Trail Uses

Hiking

No Equestrians

No Motorized Vehicles

Disseminating Information to Users is Critical

Informed choice

User responsibility

Safety

Satisfaction

Accessible formats



On-Trail Information



Buckeye Bicycle Path

Length 0.4 mi (0.6 km)

 **Bicycling**

 **No Motorized Vehicles**

 **Grade**

Typical Grade 0.9%

143 ft of the trail is 2%

5% grade is a constant zero

 **X-Slope**

Typical Cross Slope 1.7%

50% of the trail is 3%

114 ft (35 m) is 4%

 **Tread Width**

Typical Tread Width 12 ft (3.6 m)

 **Surface Type**

Asphalt

100% is Paved

Disclaimer: Trail conditions may change rapidly. Users should use common sense and exercise caution. Buckeye Bicycle Path is a public facility and is not liable for any injuries or damages. Buckeye Bicycle Path is a public facility and is not liable for any injuries or damages.

 **Trail Access Information**

Trail Access Information Sheet

Trail Uses



Hiking



No Equestrians



No Motorized Vehicles

Hazards and Obstructions



Dropoff
10 ft



Vertical Overhanging Rock



Steps
32 Railroad Ties

Pioneer

Morgan Grist Mill

Trail Length 0.7 mi (1.2 km)

Linear trail

Pioneer Trail goes through a wooded area of Hickory, Maple, and Beech trees. Seasonal wildflowers are abundant in the spring and fall.

Cumulative Elevation Change Gain 61 ft (19 m)
Loss 32 ft (10 m)



Typical Grade is 2.4%

4% of the trail is between 8% and 20%
86 ft (26 m) is between 12% and 20%
8% grade is a standard ramp.



Typical Cross Slope is 2.3%

1% of the trail is between 8% and 17%
39 ft (12 m) is between 10% and 17%



Typical Tread Width is 54 in (138 cm)

Tread Width ranges from 45 in (114 cm) to 60 in (152 cm)
Minimum Clearance is 22 in (56 cm)



Trail Surface is Soil

87% of the trail is Firm or better
525 ft (160 m) of the trail is Soft or worse

Trailhead Location



Trail Access Information

Warning: Trail conditions may have changed since this trail was assessed. Temporary obstructions (e.g. fallen trees or land slides) may not have been mapped. Maximum grades and cross slopes may vary.

This report is generated by TrailWare which has been created by Beneficial Designs, Inc.

Riverview Park / Mexican Ditch Trail System

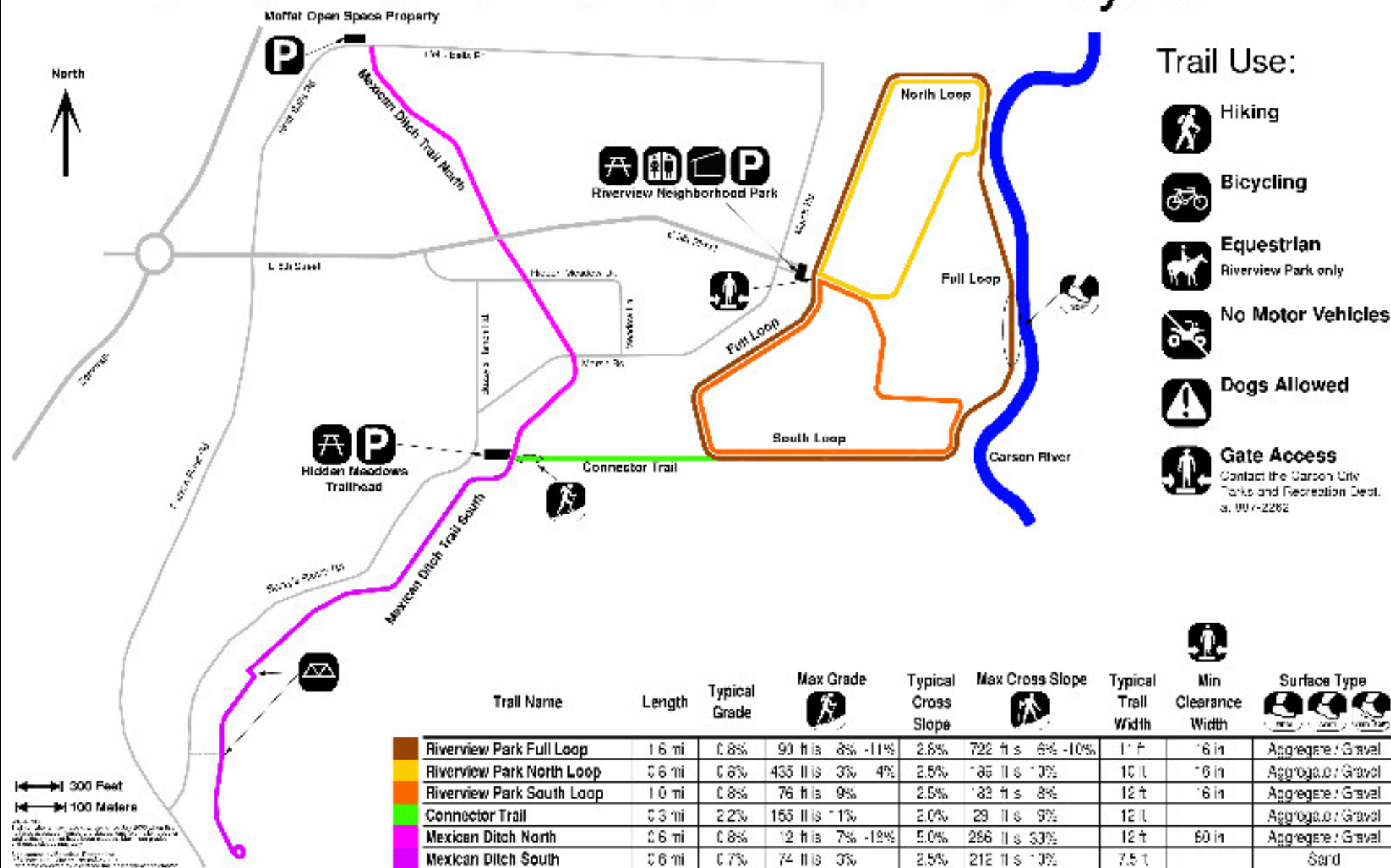

Computer Kiosk or Internet Site



TRAIL EXPLORER [HOME](#) [ABOUT US](#) [DEFINITIONS](#) [LINKS](#) [TRAIL ACCESS INFORMATION](#)

TRAIL FEATURES
Customize your search by trail use and features.

TRAIL ACCESS
Find a trail to suit your ability. Search by grade, cross-slope and surface.

TRAIL MANAGEMENT
Authorized trail managers may add or edit trail information. Contact Beneficial Designs.



QUICK TRAIL SEARCH

Type in (a few letters of) a park or trail name:

OR

View trails by state:

PICK OF THE MONTH



Big Basin Redwoods State Park
Boulder Creek, CA

Features 2,000 year-old redwoods and over 50 miles of trails. Reservations required for camping. Phone: 831.338.8860

Have you ever finished a three hour hike in one hour? Have you struggled on a "moderate" trail? Have you encountered barriers on an "easy" trail? The Trail Explorer website is unique because it uses [Trail Access Information](#) to help trail users make informed decisions about which public lands to visit, and which trails will best meet their interests, abilities and desired experiences. Trail Explorer benefits all users, but is particularly helpful for individuals with disabilities, older adults, parents with young children, and novice hikers.

[home](#) | [about us](#) | [definitions](#) | [trail access information](#) | [links](#) | [acknowledgments](#) | [disclaimer](#)

© Copyright 2001 Beneficial Designs 

TRAIL FEATURES

Customize your search by trail use and features.

TRAIL ACCESS

Find a trail to suit your ability. Search by grade, cross-slope and surface.

TRAIL MANAGEMENT

Authorized trail managers may add or edit trail information. Contact Beneficial Designs.

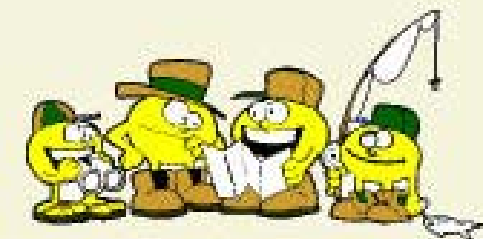

TRAIL FEATURE SEARCH - Find a trail that fits your interests and abilities by selecting your preferences from the options below. To broaden your search, remove preferences in categories of less importance. For the definition of a term, click on the term.

Choose a state:

Indiana ▼

Uses permitted:

hiking/walking/running ▼

Destination Feature:

No preference ▼

Desired trail length:

2.1 to 5.0 mi (3.3 to 8.0 km) ▼

Typical grade:

No preference ▼

Firmness required:

Firm or better ▼

Find Trails

Clear Form



TRAIL FEATURES

Customize your search by trail use and features.

TRAIL ACCESS

Find a trail to suit your ability. Search by grade, cross-slope and surface.

TRAIL MANAGEMENT

Authorized trail managers may add or edit trail information. Contact Beneficial Designs.

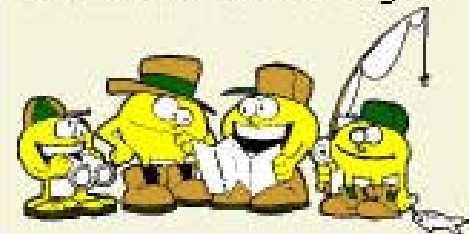

TRAIL ACCESS SEARCH - Use this advanced search to find a trail to match your abilities by selecting your preferences from the options below. To broaden your search, remove preferences in categories of less importance. For the definition of a term, click on the term.

Choose a state:

Desired trail length:

Firmness required:

Typical grade:

Typical cross-slope:

Typical tread width:

Min clearance width:





9 trails found. Use the "Back" button on your browser to refine your selection.
 Click on the trail name for more information.
 Click on the column heading to sort by column.

Trail	Park	State	Length	Typical Grade	Max Grade	Typical Xslope	Max Xslope	Typical Tread Width	Min Clear Width	Surface Firmness	Surface Mats
Trail 10	McCormick's Creek State Park	IN	0.7 miles (1.1 km)	3.3%	34%	3.5%	12%	50 in (126 cm)	na	Firm	Rock/Boulder
Trail 8	McCormick's Creek State Park	IN	0.7 miles (1.1 km)	2.3%	12%	1.1%	4%	60 in (152 cm)	na	Paved	Asphalt
Trail A	McCormick's Creek State Park	IN	0.2 miles (0.3 km)	2.2%	9%	1.3%	4%	58 in (148 cm)	na	Firm	Crushed Stone (Fines)
Trail 6	Spring Mill State Park	IN	0.4 miles (0.7 km)	2.3%	7%	2.2%	4%	60 in (152 cm)	na	Paved	Asphalt
Trail 7	Spring Mill State Park	IN	0.9 miles (1.5 km)	3.3%	23%	3.1%	8%	52 in (131 cm)	na	Firm	Soil
Trail 7 Spur to Trail 4	Spring Mill State Park	IN	0.4 miles (0.6 km)	3.9%	27%	2.8%	9%	49 in (125 cm)	na	Firm	Soil
Trail 10 Spur to Camels Back	Turkey Run State Park	IN	0.1 miles (0.2 km)	0.9%	2%	1.8%	5%	60 in (152 cm)	na	Firm	Crushed Stone (Fines)
Trail 11	Turkey Run State Park	IN	0.2 miles (0.3 km)	3.1%	9%	4.3%	11%	60 in (152 cm)	na	Firm	Crushed Stone (Fines)
Trail 7 Spur to Campground	Turkey Run State Park	IN	0.1 miles (0.2 km)	3.3%	6%	2.7%	5%	60 in (152 cm)	na	Firm	Soil



Trail 11

Turkey Run State Park

Route 1 Box 164
Marshall, IN 47859

County:

Phone: (765) 597-2635

FAX:

Email:

Website: <http://www.state.in.us/dnr/parklake/parks/turkeyrun.html>

Length: 0.2 miles (0.3 km)

Destination: Lieber Memorial & Log Church

Destination Type: Historical

Trail 11 starts from the Service Road besides the Turkey Run Inn. A short hike about Turkey Run Hollow to the Lieber Memorial and Log Church.

Cumulative Elevation Gain: 23 ft (7 m)

Cumulative Elevation Loss: 4 ft (1 m)

Uses: Hiking

Facilities: Historical

Features: Lieber Memorial
Log Church

Obstructions:



Typical Grade is 3.1%
7% of the trail is 6% to 9%
64 ft (20 m) is 8% to 9%
8% grade is a standard ramp.



Minimum Tread Width is 60 in (152 cm)
Maximum Tread Width is 60 in (152 cm)



Typical Cross Slope is 4.3%
18% of the trail is 6% to 11%
160 ft (49 m) is 10% to 11%



Trail Surface is Crushed Stone (Fines)
100% of the trail is Firm
0 ft (0 m) of the trail is Soft

What else could we do to improve trail access?

Develop standards for trail design

Obtain funding for UTAP assessments

Automate UTAP so one person can complete all measurements

Design a trail barrier that prevents vehicle access but can be used by people with mobility devices

ADA Compliance

Proposed guidelines available at
www.access-board.gov

Recreation trails

Outdoor recreation access routes

Picnic and campground facilities

Beach access

Research Funded by the National Center on Accessibility

Built test trails and surfaces with
different grade and cross slopes

Conducted human subject testing

Measured difficulty ratings in
comparison to existing standards

Made recommendations

ADA Recreation Trail

Grade

up to 30% of length $> 8.33\%$

5% for any distance

8.33% for 200 feet

10% for 30 feet

12.5% for 10 feet

14% for 5 feet in drains if cross slope $< 5\%$

ADA Outdoor Access Route

Grade

up to 30% of length $>$ 8.33%

5% for any distance

8.33% for 50 feet

10% for 30 feet

Cross Slope

3.3%

5% to ensure drainage

Develop standards for trail design

Designing Sidewalks
and Trails for Access
Part I and Part II

Access Board Negotiated Rulemaking
Committee

Feedback on US Forest Service
guidelines



Recreation Trail Program (RTP) National Funding Priorities

Goal to enhance trail access

RTP is state aid for trail development,
maintenance and
signage

Funding for motorized
and non-motorized
trails



**Tahoe Meadows
Interpretive
Trail**

Length 1.5 mi (2.3 km)

 Hiking

 Dogs On Leash

 Grade

Typical Grade 2.3%

7% of the trail is 6%

927 ft (283 m) is 7%

6% grade is a standard ramp.

 X-Slope

Typical Cross Slope 2.0%

98% of the trail is 3% to 5%

304 ft (93 m) is 6% to 10%

 Tread
Width

Typical Tread Width

7.5 ft (2.3 m)

Minimum Clearance Width

42 in (107 cm)

 Surface
Type

Aggregate / Gravel

82% is Firm or better

1408 ft (429 m) is Soft or worse

 Obstructions

Rock 2 inches high

Entrenchment 1 inch

deep

Road 2 inches high

WARNING: The conditions may have changed since any 2010 when this information was prepared. Temporary obstructions (e.g. fallen trees or dead animals) may not have been tagged. It is the user's responsibility to check for such conditions before using the trail.

This project is funded by Nevada Dept. of Conservation and Forestry, U.S. Forest Service, and Washoe County. For more information, contact the project manager.

 Trail Access
Information

Nevada Recreation Trails (NV NRT)

The NV NRT project has been ongoing since 2003. The NV NRT goal is to make Trail Access Information (TAI) widely available for a variety of trails in Northern NV. During 2006, priority trails were determined for Douglas, Washoe, Carson City, and Sparks Counties.



Trail Access Information for Northern Nevada

County	Trail Name	Length	Type of Trail
Washoe County			
	Rancho San Rafael Arboretum (pedestrian only)	1.5 miles	urban recreation
	Ophir Creek Trail (Davis Creek Park to Tahoe Meadows, trailhead both ends)	7 miles	urban shared-use path
	Tahoe Meadows Interpretive Trail (W451 just past Mt. Rose summit – Forest Service permission)		1 mile front-country recreation
	Mt. Rose Summit Loop Trail (Trailhead to be constructed 2003)	7 miles	urban shared-use path
	Whites/Jones Loop (Galena Regional Park)	9.5 miles	urban shared-use path
	Whites/Thomas Loop (Two trailheads to be constructed 2003)	5 miles	urban shared-use path
	Thomas Creek Trail (To be constructed 2003)	8 miles	urban shared-use path
	Truckee River Bike Path (Mayberry, Fishermen I & II Parks)	7 miles	urban shared-use path
	Rancho San Rafael Herma Pond		urban shared-use path

Perform UTAP

Clearly record the exact location of segments

Name segments descriptively (i.e. Rock Park to Glendale Park)



High Efficiency Trail Assessment Process

Automate UTAP
so one person
can complete all
measurements
at a speed of at
least 1 mph

















version 2.04a

Welcome to HETAP Pro 2.0

Created and distributed by Beneficial Designs
copyright © Beneficial Designs, Inc. 2007

www.beneficialdesigns.com



(Start) Data Collection

Calibrate Sensors Now

Change Database Login

PMD Setup



Last Station Recorded

55

Soft

Sand

10.4 Ft

11.8 %

-0.9 %

Copy Surf. Data ->

Tread Width:

Surface Category:

Surface Type:



Distance:



Grade:



Cross Slope:

Current Station To Record



in

Set MCW

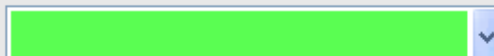

Offline

Offline

Offline

Record Station

Add Features

Return Home

Distance Hold

Manual Entry

View Data

Notes/Edit/New Segment

Alarm Settings

Current Segment:

4 Quail 2007-08-02

Outslope

Check Outslope Direction

<- Left

Right ->

Orientation

Forwards

Backwards



Settings

Cancel

Save Image

Compass Heading:



GPS Location and Status

Lat:

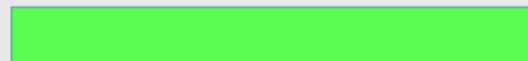

Lon:

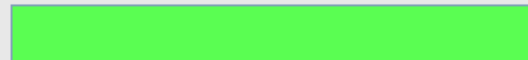

Apprx. Err:



Elev:

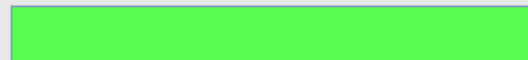

Error: Garmin GPS is not connected



Distance:

Type:

Description:

Copy from Previous Data

Record Feature

Stations

View Data

Zone

Trail Bed Visual

Dimensions

L W H

Units of Measure:

Remaining Tread:

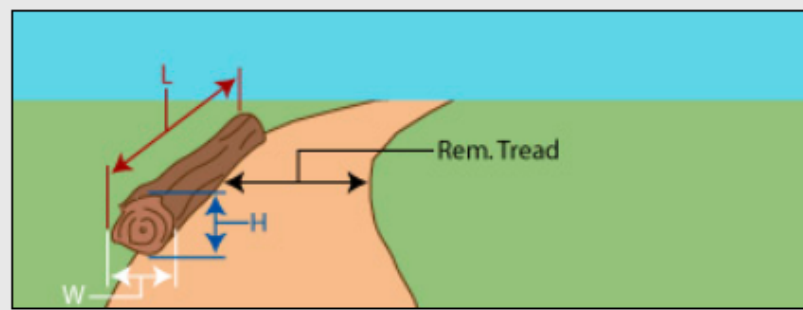

Qty: End

Optional Data

Recommended Action:

Materials Needed:

Is the Built Feature Accessible?

n/a Yes No

Notes are not auto-filled.

Add Notes

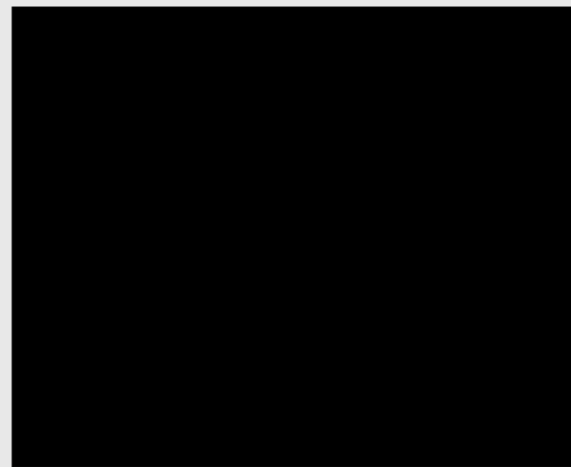

Settings

Cancel

Save Image

Alarm Settings



Enable Alarms and Set Alarm Thresholds

Distance

Alarm Enabled

Meters

Cross Slope

Alarm Enabled

Percent

Grade

Alarm Enabled

Percent

Inslope/Outslope

Slope Changes

Alarm Enabled

Done

Cancel

Accessible Trail Gate Barrier



Enable all permitted users, including those using mobility devices

Prevent trail access by motorized vehicles

Project Goals

Develop a trail gate that:

Allows all non-motorized users and hikers using personal mobility devices (PMDs)

Prevents motorized trail vehicle (MTV) access,

Is consistent with the spirit of accessibility legislation

Pedastrain Trail Users:

Hikers

Manual Wheelchair Users

Power Wheelchair Users

Scooter Users

Rollater Users

Human Transporter Users

Document performance characteristics of motorized trail vehicles (MTVs) and personal mobility devices (PMDs).

Motorcycle Front View

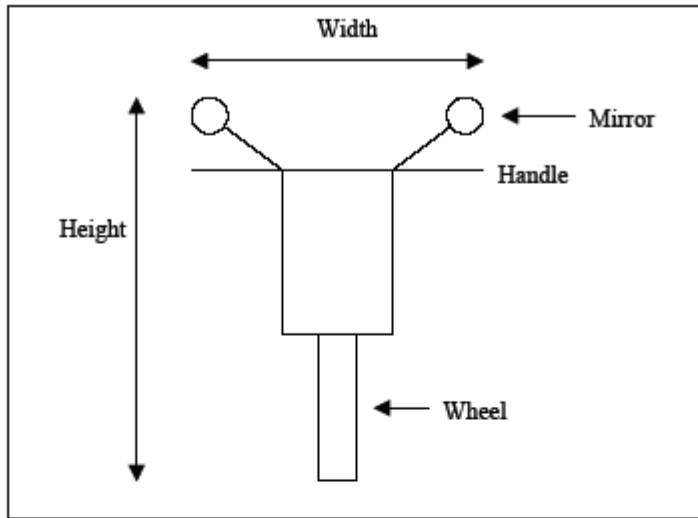

Motorcycle Side View

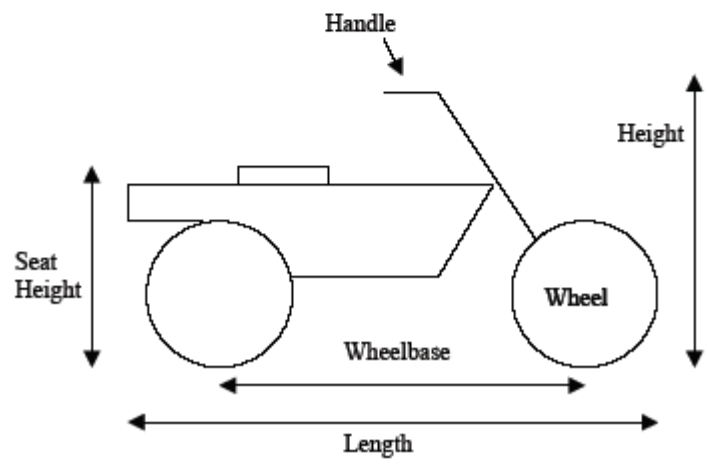

Scooter Side View

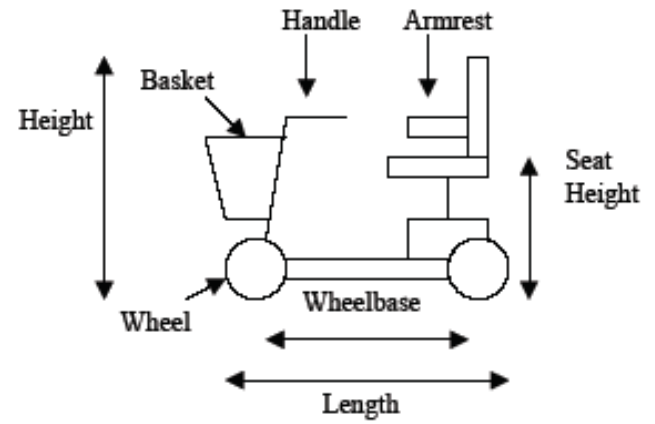

Scooter Front View

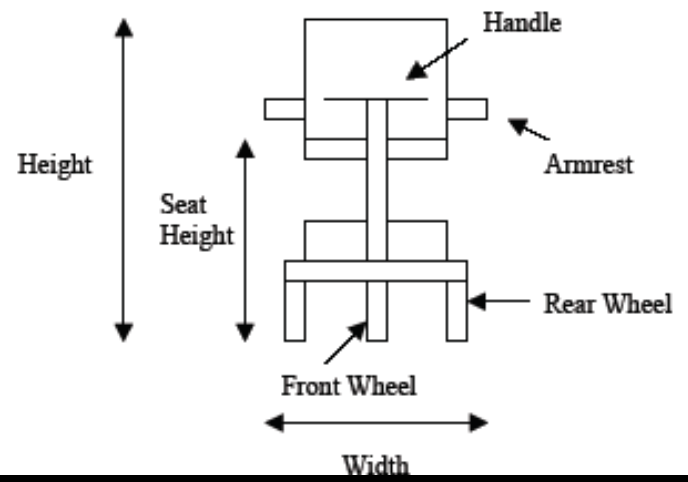





Install trail tread surface materials on new and existing trail segments

Rock causeways in wet areas

Minimize vegetation trampling

Reduce erosion runoff into stream

Channel users on to a designated pathway

Keep users safe and dry

Provide a stable and level trail tread surface material

Simple, interlocking installment

Durable and long lasting

ADA compliant material

Blend in nicely with natural
environment

Additional tread material in next
phase



GeoRunner



Molded Mini-Grid

Safety Deck II









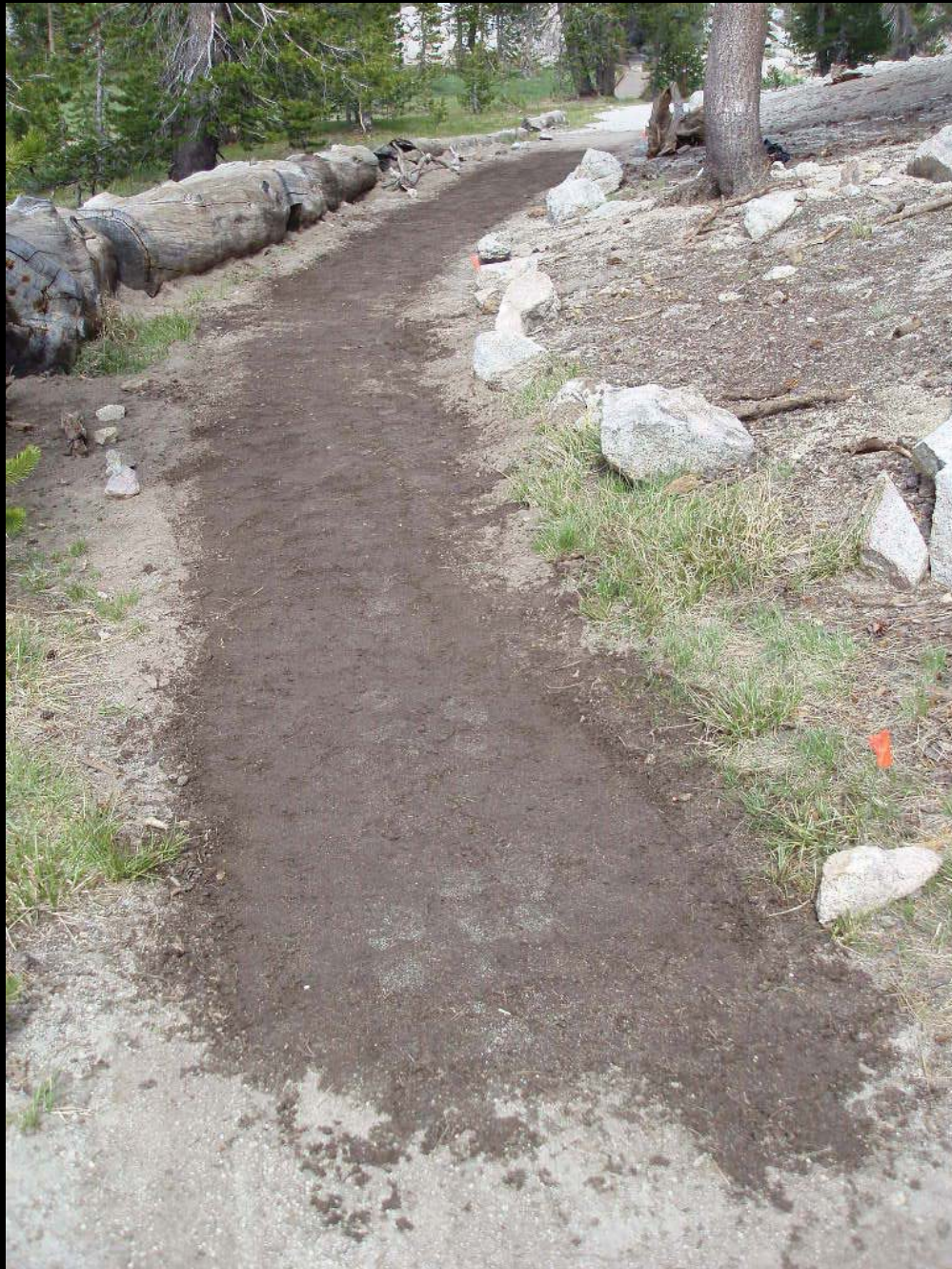

Rotational Penetrometer



Objective surface
measurement device

Draft Standard for
measure of firmness
and stability under
development

Available from
Beneficial Designs

Analyze the UTAP Information

Enter the data into
TrailWare

Second person
verifies data entry

Print all reports and
completed forms

Create a summary of
key trail issues

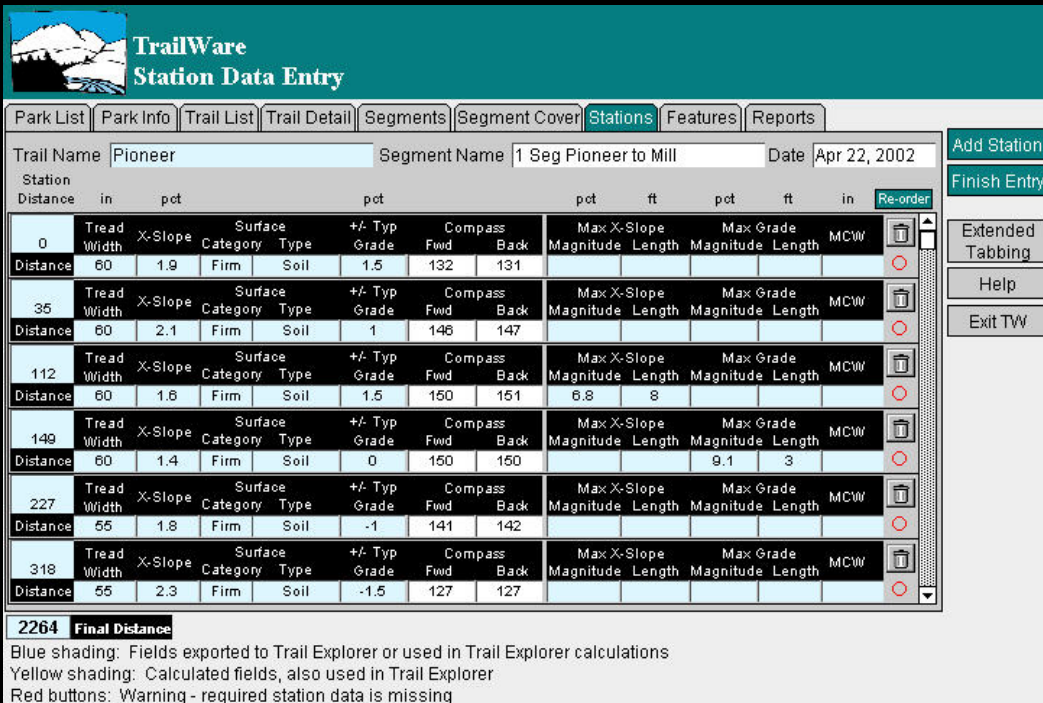

TrailWare
Station Data Entry

Park List | Park Info | Trail List | Trail Detail | Segments | Segment Cover | Stations | Features | Reports

Trail Name: Pioneer Segment Name: 1 Seg Pioneer to Mill Date: Apr 22, 2002

Station	Distance	in	pct	pct	pct	ft	pct	ft	in	Re-order
0	Tread Width	X-Slope	Surface Category	Type	+/- Typ Grade	Compass Fwd	Back	Max X-Slope Magnitude	Max Grade Length	MCW
Distance	60	1.9	Firm	Soil	1.5	132	131			
35	Tread Width	X-Slope	Surface Category	Type	+/- Typ Grade	Compass Fwd	Back	Max X-Slope Magnitude	Max Grade Length	MCW
Distance	60	2.1	Firm	Soil	1	146	147			
112	Tread Width	X-Slope	Surface Category	Type	+/- Typ Grade	Compass Fwd	Back	Max X-Slope Magnitude	Max Grade Length	MCW
Distance	60	1.6	Firm	Soil	1.5	150	151	6.8	8	
149	Tread Width	X-Slope	Surface Category	Type	+/- Typ Grade	Compass Fwd	Back	Max X-Slope Magnitude	Max Grade Length	MCW
Distance	60	1.4	Firm	Soil	0	150	150		9.1	3
227	Tread Width	X-Slope	Surface Category	Type	+/- Typ Grade	Compass Fwd	Back	Max X-Slope Magnitude	Max Grade Length	MCW
Distance	55	1.8	Firm	Soil	-1	141	142			
318	Tread Width	X-Slope	Surface Category	Type	+/- Typ Grade	Compass Fwd	Back	Max X-Slope Magnitude	Max Grade Length	MCW
Distance	55	2.3	Firm	Soil	-1.5	127	127			

2264 Final Distance

Blue shading: Fields exported to Trail Explorer or used in Trail Explorer calculations
Yellow shading: Calculated fields, also used in Trail Explorer
Red buttons: Warning - required station data is missing

Buttons: Add Station, Finish Entry, Extended Tabbing, Help, Exit TW

Meet with Agency Representatives

Collate the assessment
information in an agency
report

Provide a map of the trail segment layout

Review all data gathered

Discuss actions and timelines for key trail issues

Identify final signage locations



CARSON

River view
Trail

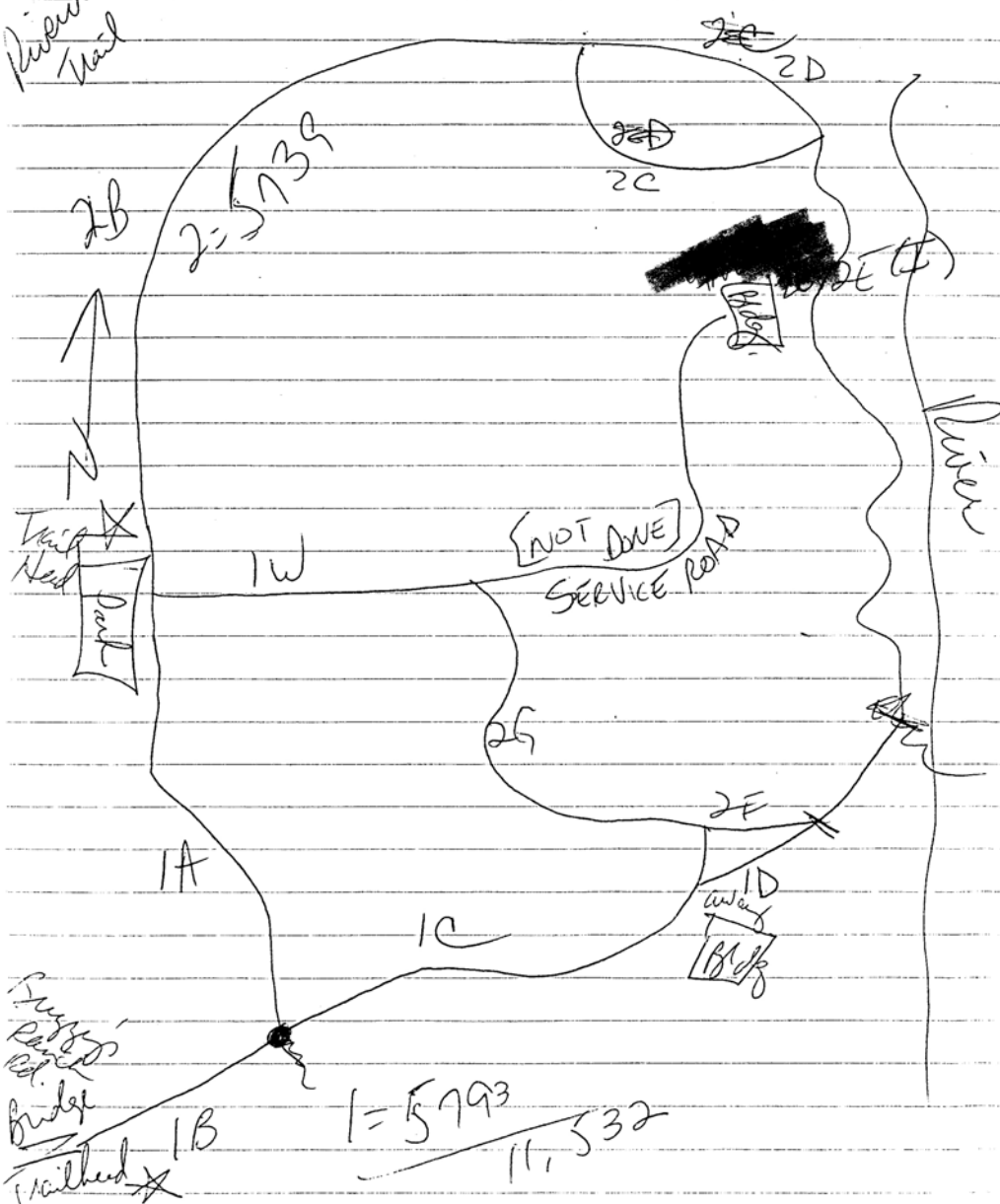

Sussex
Rabbit
Ct.
Bridg
walked X

1-5793
11.532

Riverview Park

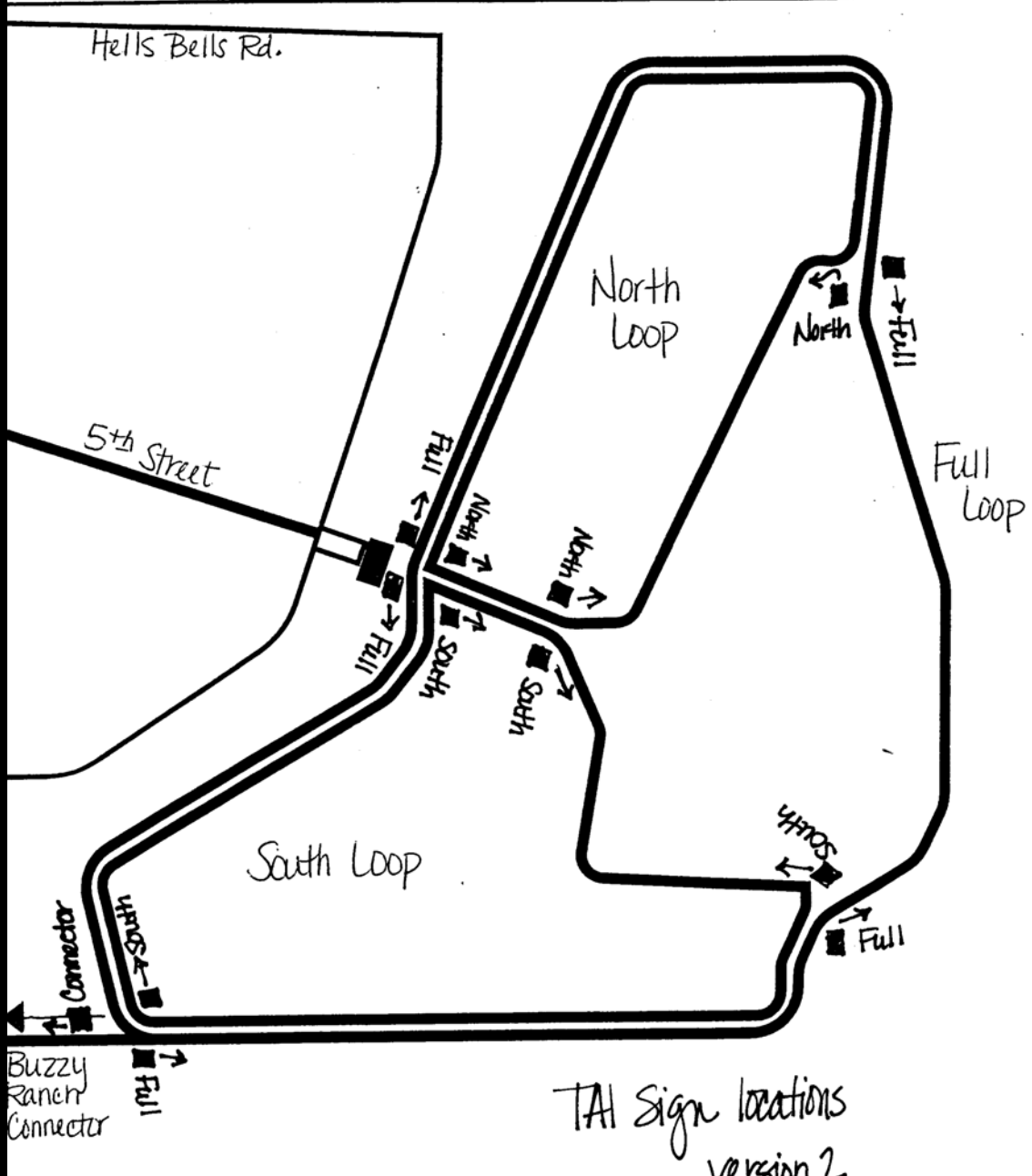

TAI Sign locations
version 2

Riverview Park / Mexican Ditch Trail System

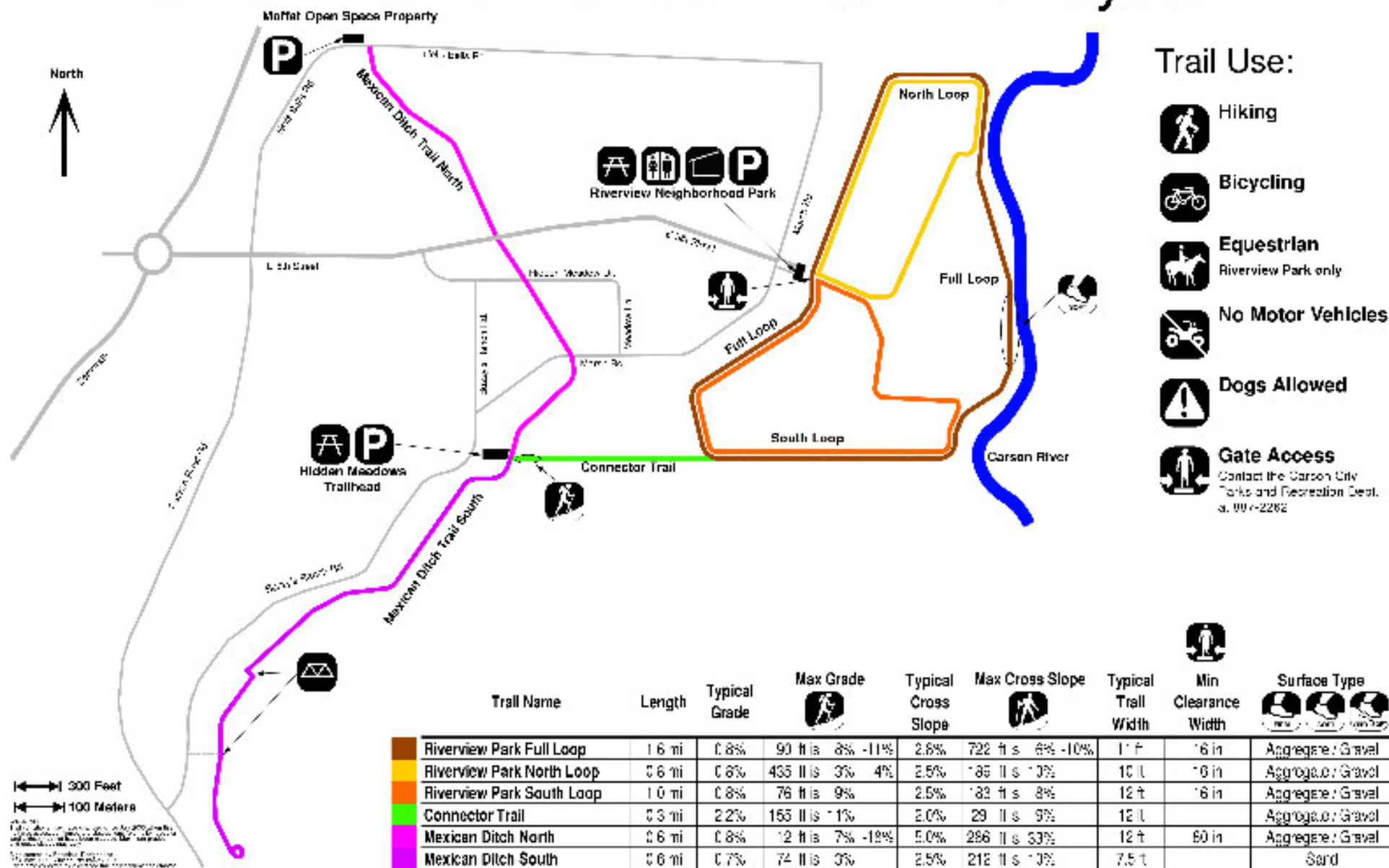

Install information signs

Demonstrative signs explaining project improvements & needed user cooperation

Objective information about trail conditions

Riverview Park / Mexican Ditch Trail System



Trail Use:

- Hiking
- Bicycling
- Equestrian
- Dogs Allowed
(on leash)
- No Motor Vehicles
Forest City Maintenance Vehicle
- 16" Minimum Clearance Width
Consult the Carrow City Parks and Recreation Dept. at 987-2232 for gate access.

Trail Access Information

Trail Name	Length	Typical Grade	Max Grade	Typical Max Cross Slope	Typical Trail Width	Clearance Width	Surface Type
Riverview Park (Full Loop)	1.8 mi	0.8%	30 R is 9% - 11%	2.8%	7-22 R is 8% - 10%	11R	Aggregate / Gravel
Riverview Park (North Loop)	0.8 mi	0.8%	4-35 R is 3% - 4%	2.5%	18-9 R is 10%	10 R	Aggregate / Gravel
Riverview Park (South Loop)	1.0 mi	0.8%	28 R is 9%	2.5%	18-9 R is 8%	12 R	Aggregate / Gravel
Connector Trail	0.3 mi	2.2%	15-8 R is 11%	2.0%	20 R is 8%	12 R	Aggregate / Gravel
Mexican Ditch Trail (North)	0.6 mi	0.8%	12 R is 7% - 18%	0.0%	2-8 R is 33%	12 R	Aggregate / Gravel
Mexican Ditch Trail (South)	0.8 mi	0.7%	7-4 R is 3%	2.5%	2-12 R is 10%	8 R	Aggregate / Gravel / Sand

A 16" x 12" sign is on all 8% grades.

The Nature Trail

Round Trip from
Parking Lot
Rancho San Rafael Park

Length 1.1 mi (1.8 km)



Hikers



Dogs on Leash
per posted restrictions



No Bikes



No Motorized
Vehicles



Grade

Typical Grade 5.9%

21% of the trail is 8% to 14%

424 ft (129 m) is 14% to 25%
0% grade is a standard ramp.



X-Slope

Typical Cross Slope 5.1%

827 ft (252 m) is 8% to 12%

311 ft (95 m) is 12% to 22%
0% grade is a standard ramp.



Tread
Width

Typical Tread Width
3.7 ft (1.1 m)

0.4 mi (0.6 km) is less than 32 in
0.1 mi (0.2 km) is less than 25 in



Surface
Type

Soil

Typical Firmness - 0.20
Minimum Firmness - 0.62



Typical Stability - 0.38
Minimum Stability - 1.15



98% is Firm or Better

131 ft (40 m) is Soft

Obstructions



3 in. Roots
Dist. from trailhead:
0.4 mi (0.65 km)
Remaining tread: 12"



7 in. Rocks
Dist. from trailhead:
0.4 mi (0.65 km)
Remaining tread: 22"

NO TRAIL: Trail closed due to fire. Reopened on August 12, 2008. For more info visit us at www.nps.gov. Trail closed 12/18/08. For more info visit us at www.nps.gov. For more info visit us at www.nps.gov.

Copyrighted Beneficial Design Inc. P.O. Box 0069, Mintier, NV 89423-0069 using data collected by a certified trail assessment coordinator.

A Trail Access
Information

The Nature Trail

Round Trip from
Parking Lot
Rancho San Rafael Park

Length 1.1 mi (1.8 km)



Hikers



Dogs on Leash
per posted restrictions



No Bikes



No Motorized
Vehicles



Grade

Typical Grade 5.9%

21% of the trail is 8% to 14%

424 ft (129 m) is 14% to 25%
8% grade is a standard ramp.



X-Slope

Typical Cross Slope 5.1%

827 ft (252 m) is 8% to 12%

311 ft (95 m) is 12% to 22%
8% grade is a standard ramp.



Tread
Width



Tread
Width

Typical Tread Width
3.7 ft (1.1 m)

0.4 mi (0.6 km) is less than 32 in
0.1 mi (0.2 km) is less than 25 in



Surface
Type

Soil

Typical Firmness - 0.20
Minimum Firmness - 0.62



Typical Stability - 0.38
Minimum Stability - 1.15

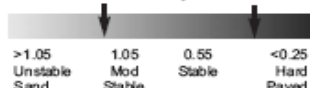

98% is Firm or Better

131 ft (40 m) is Soft

Obstructions



3 in. Roots
Dist. from trailhead:
0.4 mi (0.68 km)
Remaining tread: 12"



7 in. Rocks
Dist. from trailhead:
0.4 mi (0.69 km)
Remaining tread: 22"

WARNING: Trail conditions may have changed since August 2008 when this trail was assessed. Temporary obstacles such as fallen trees and land slides were not mapped.

Sign created by Beneficial Design Inc., P.O. Box 0069, Mintier, NV 89423-0069 using data collected by a certified trail assessment coordinator.



Trail Access
Information

Bureau of Land Management
Silver Saddle Ranch
Trails



A detailed map of the Silver Saddle Ranch trails, showing a network of paths in various colors (blue for paved, green for dirt, red for gravel) and terrain features like a creek and a reservoir. The map includes labels for 'Paved Path', 'Dirt Path', 'Gravel Path', 'Creek', 'Reservoir', and 'Trailhead'. A scale bar and a north arrow are located below the map.

Legend:

- Blue line: Paved Path
- Green line: Dirt Path
- Red line: Gravel Path
- Blue area: Creek
- Blue circle: Reservoir
- Black square: Trailhead
- Black line: Boundary
- Black line: Road
- Black line: Railroad
- Black line: Power Line

- 1.1
- 1.2
- 1.3
- 1.4
- 1.5
- 1.6
- 1.7
- 1.8

Beneficial Designs, Inc.

Minden, Nevada

www.beneficialdesigns.com

trails@beneficialdesigns.com

775.783.8822 voice

775.783.8823 fax

*Working toward universal access
through research, design & education*