

# Interframe coding of video signals

---

- Adaptive intra-interframe prediction
- Conditional replenishment
- Rate-distortion optimized mode selection
- Motion-compensated prediction
- Hybrid coding: combining interframe prediction and intraframe transform coding



# Interframe coding of video signals

. . . exploits similarity of successive pictures



[Second Edition.]

## PATENT SPECIFICATION



Convention Date (United States) : April 25, 1929.

341,811

Application Date (in United Kingdom) : April 25, 1930. No. 12,805 / 30.

Complete Specification Accepted : Jan. 22, 1931.

COMPLETE SPECIFICATION.

### Improvements relating to Electric Picture Transmission Systems.

We, THE BRITISH THOMSON-HOUSTON COMPANY LIMITED, a British Company, having its registered office at Crown House, Aldwych, London, W.C. 2, (Assignees of  
5 RAY DAVIS KELL, of 111, Sanders Avenue, Scotia, County of Schenectady, State of New York, United States of America, a citizen of the United States of America), do hereby declare the nature of this invention and in what manner the same is to  
10 be performed, to be particularly described and ascertained in and by the following

55 fineness of detail is limited only by the speed of the action to be transmitted.

The invention will be better understood from the following description when considered in connection with the accompanying drawings in which Fig. 1 illustrates a picture transmitting apparatus wherein  
60 the invention has been embodied; and Figs. 2 to 5 illustrate various details of an apparatus which may be utilised to receive the difference between the successive images of a picture or moving object.  
65

“It has been customary in the past to transmit successive complete images of the transmitted picture.”

[...]

“In accordance with this invention, this difficulty is avoided by transmitting only the difference between successive images of the object.”

# Adaptive intra-interframe Prediction

Predictor is switched between two states:

A: Intraframe prediction for moving or changed areas.

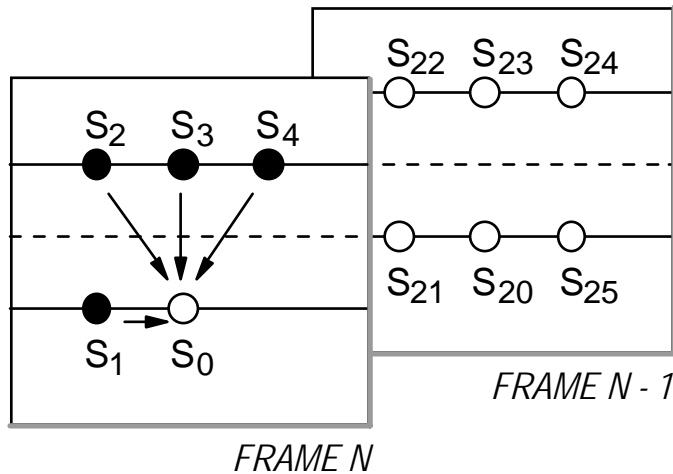

B: Interframe prediction (previous frame prediction) for still areas of the picture.

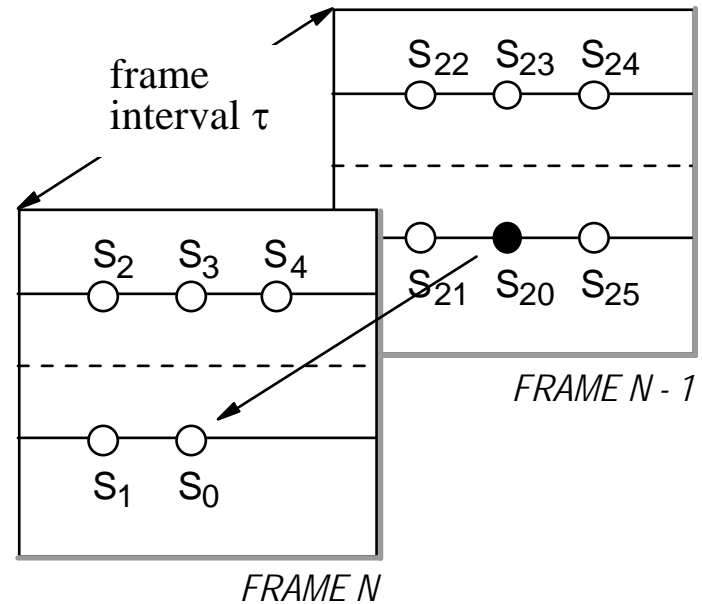

$$\hat{S}_{\text{intra}} = a_1 S_1 + a_2 S_2 + a_3 S_3 + a_4 S_4$$

$$\hat{S}_{\text{inter}} = S_{20}$$



# Intra-interframe DPCM: feedback adaptation

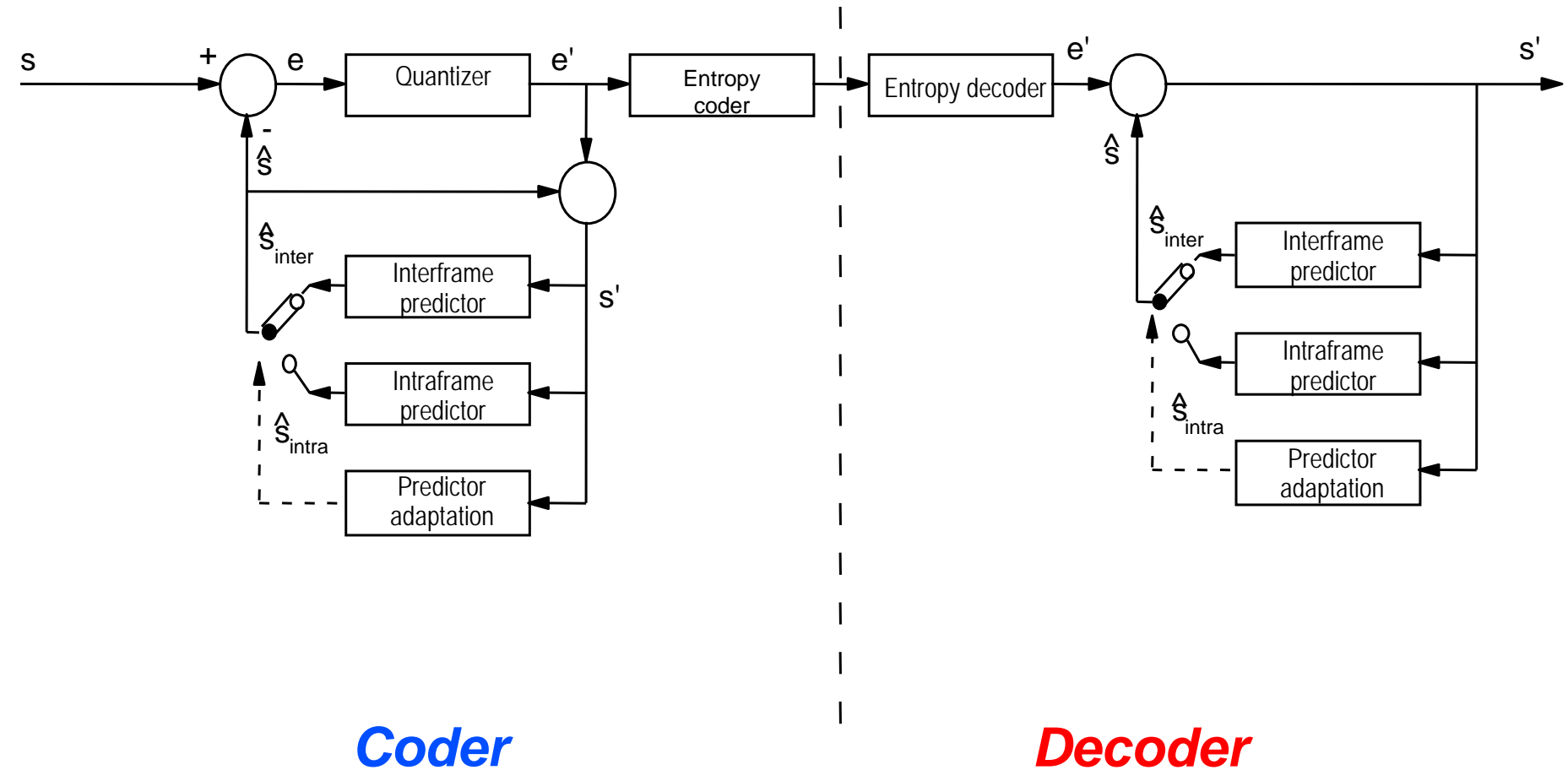

# Intra-interframe DPCM: feedforward adaptation

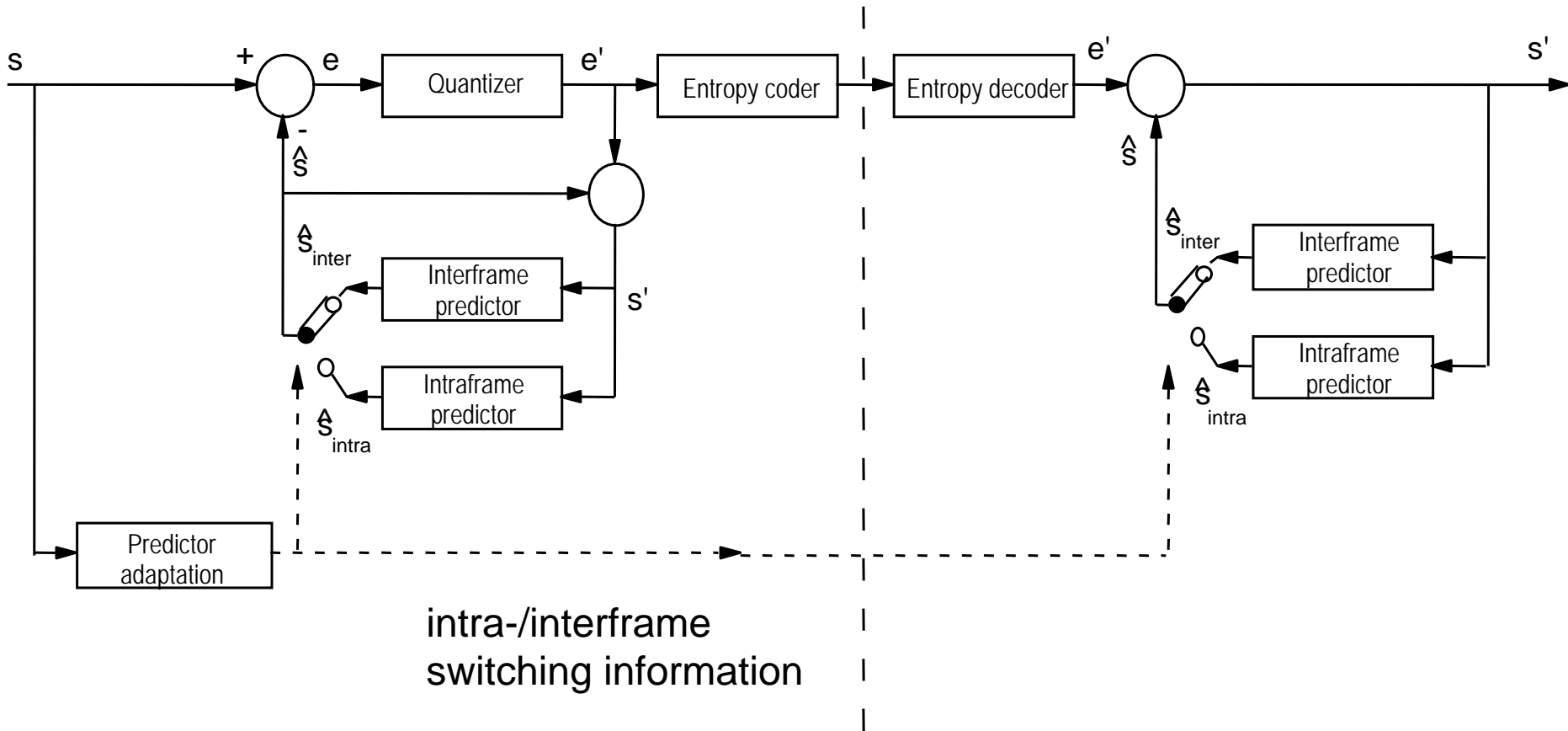

**Coder**

**Decoder**



# Conditional replenishment

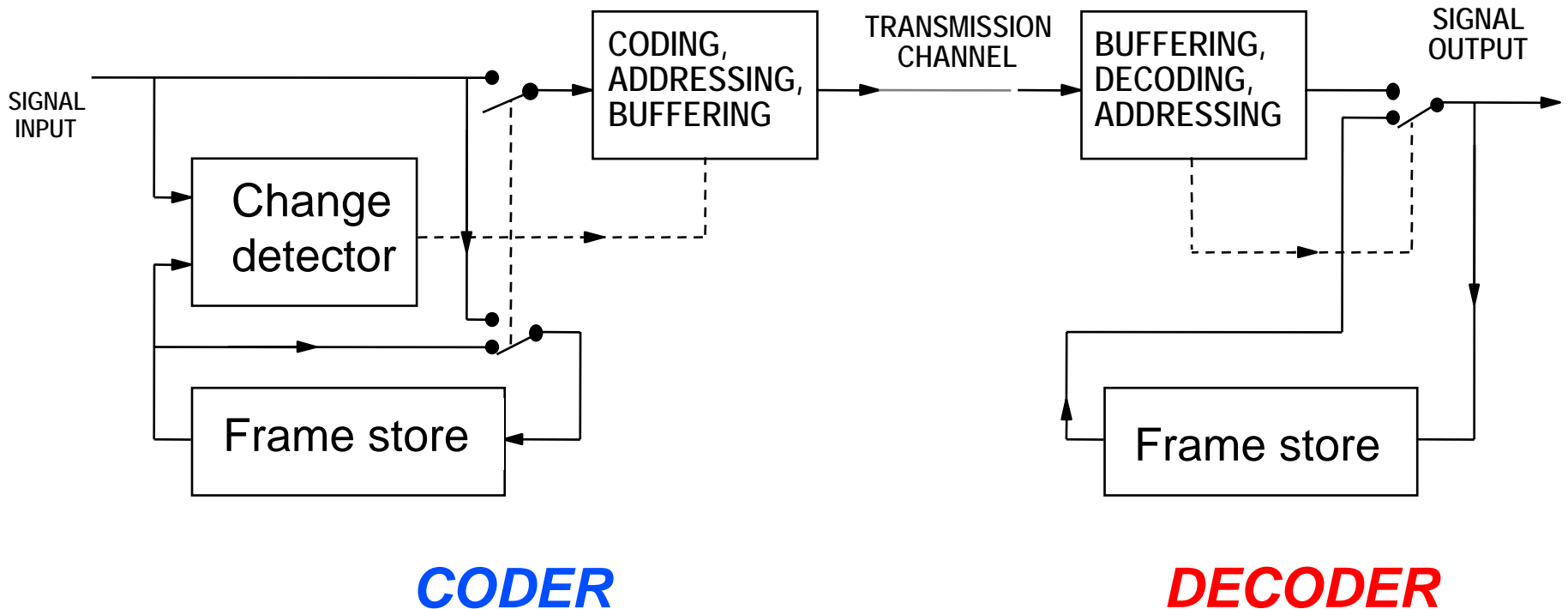

- Still areas: repeat from frame store
- Moving areas: encode and transmit address and waveform



# Change detection

## ■ Example of a pixel-wise change detector

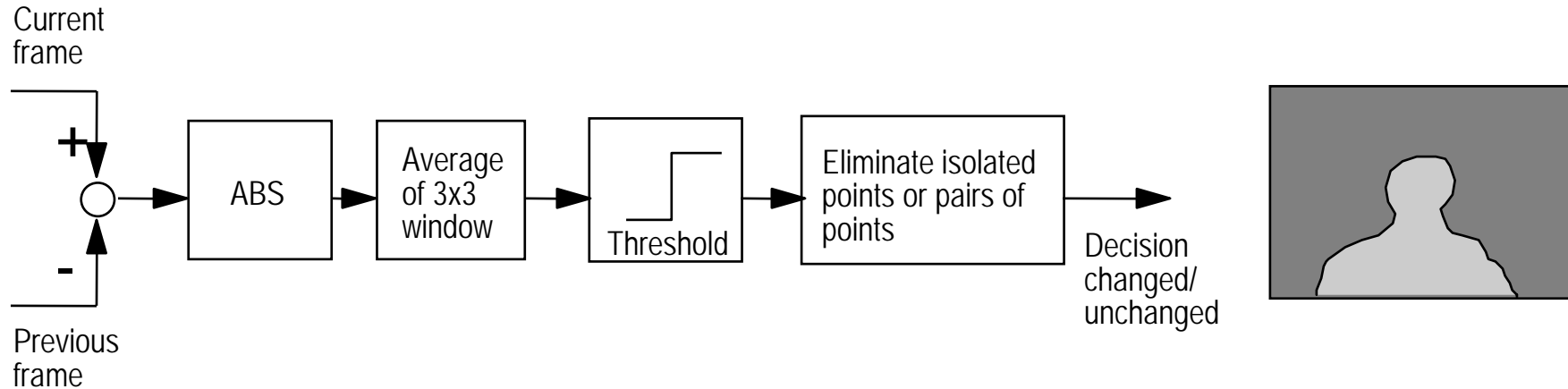

## ■ Example of a block-wise change detector

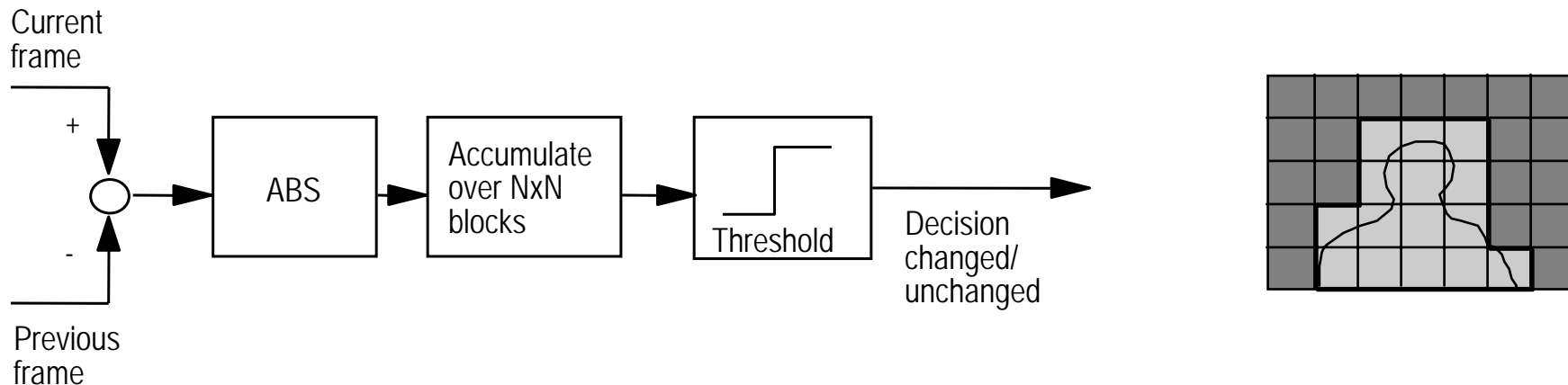

# Example: pixel-wise change detection



Two successive video frames



Change  
detection  
mask



[Xinqiao Liu, EE368B class project, 2000]

# Crawford noise reduction filter

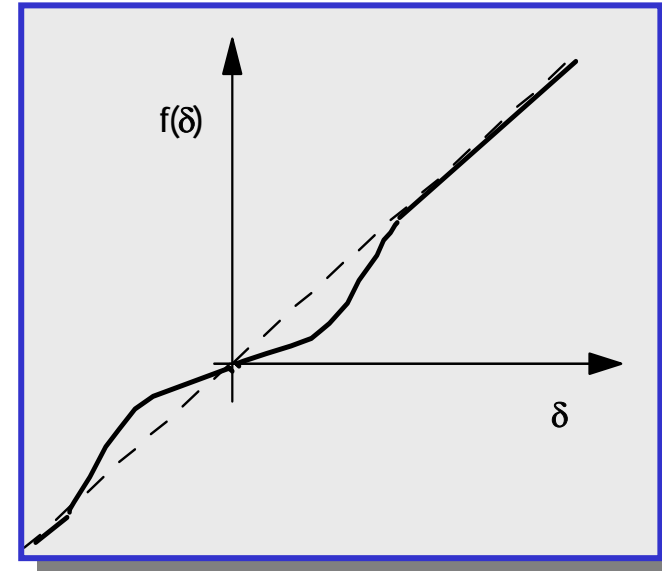
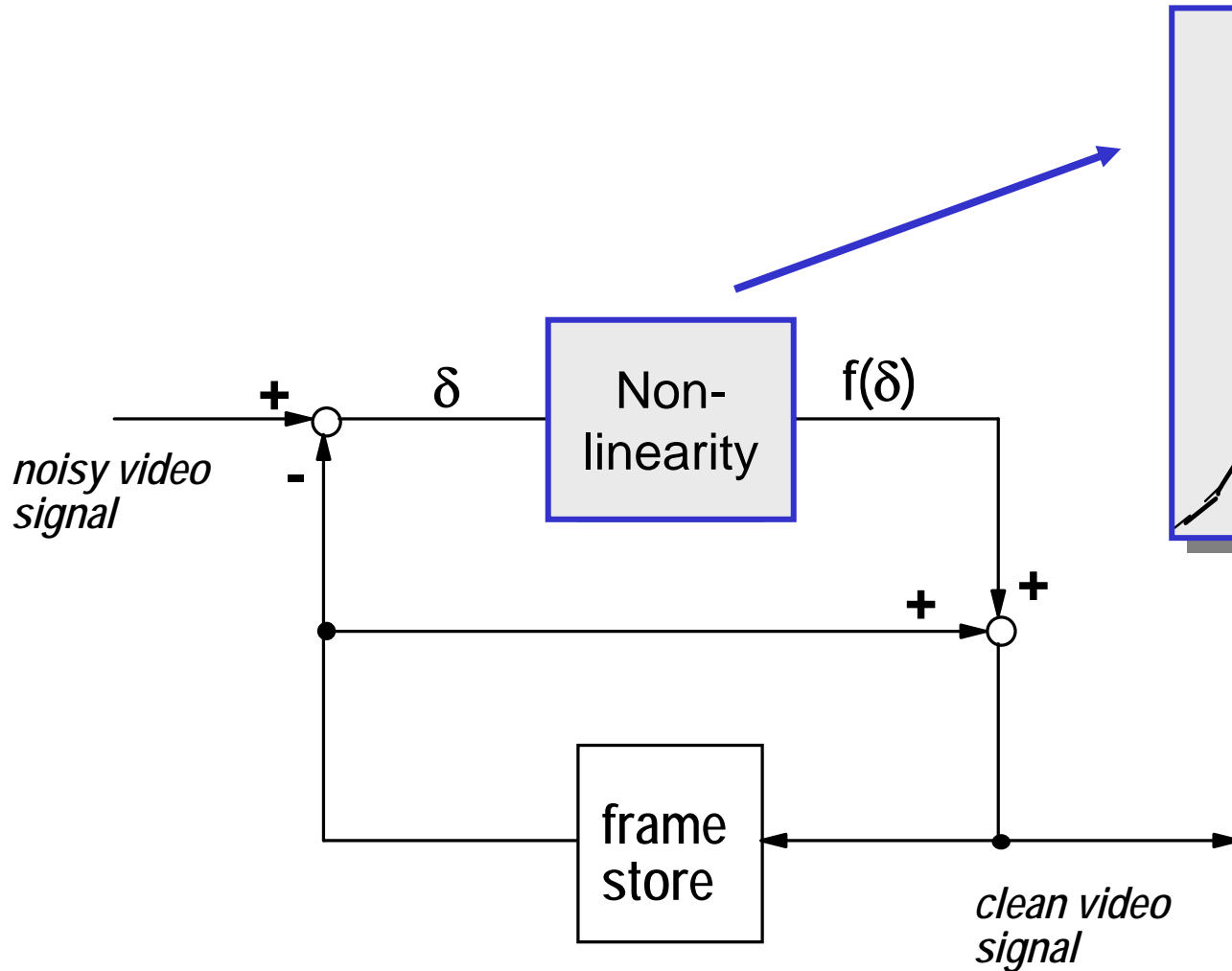

# The “Dirty Window” effect

- Conditional replenishment scheme with change detection threshold set too high leads to the subjective impression of looking through a dirty window.

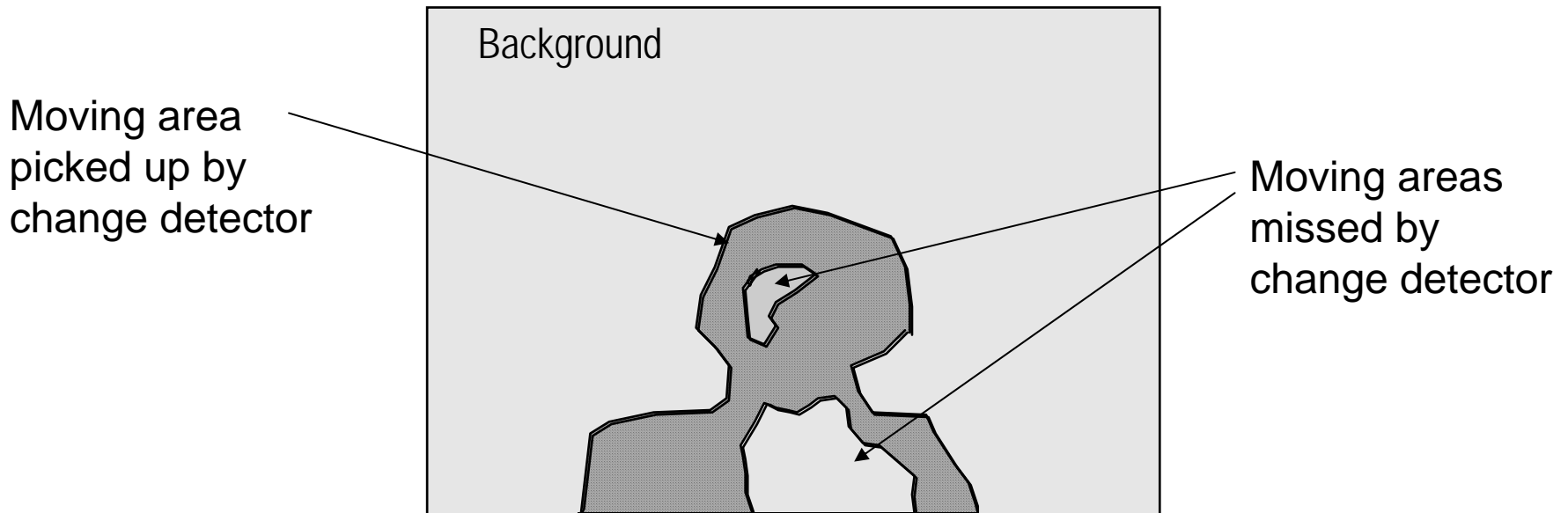

# Rate-distortion optimized mode selection

- How to choose the decision threshold, if distortion  $D$  shall be minimized for a given rate  $R$ ?
- Assumptions
  - Blockwise mode selection, block index  $i$
  - Additive overall distortion  $D = \sum_i D_i$  and rate  $R = \sum_i R_i$
- Lagrangian cost function

$$J = D + \lambda R = \sum_i D_i + \lambda R_i = \sum_i J_i$$

- Strategy: minimize  $J_i$  for each block  $i$  separately, using a common Lagrange multiplier  $\lambda$



# Rate-distortion optimized mode selection (cont.)

- Consider 2 blocks with  $D(R) = D_1(R_1) + D_2(R_2)$
- Intra-coding only

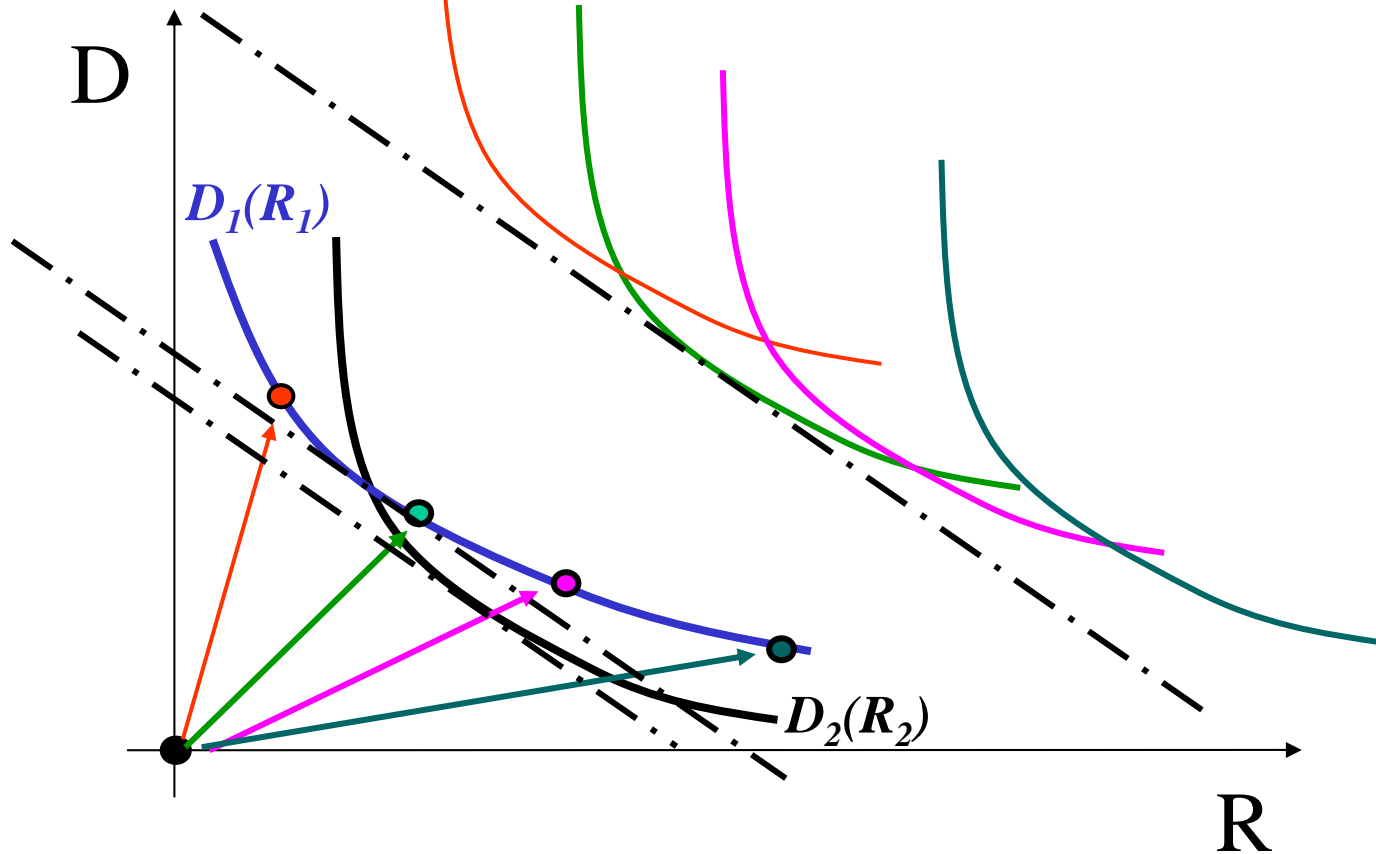

# Rate-distortion optimized mode selection (cont.)

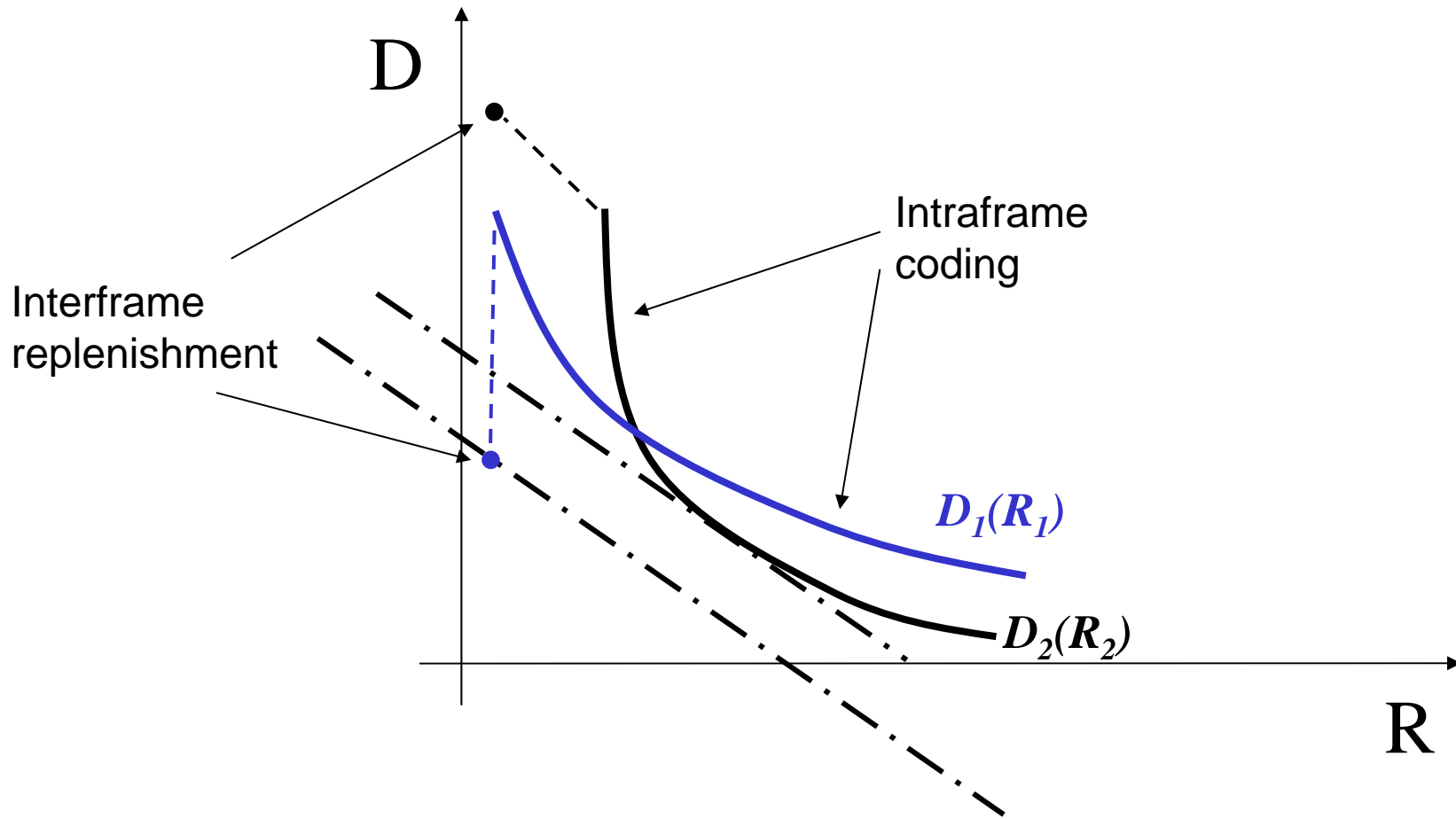

# Motion-compensated prediction

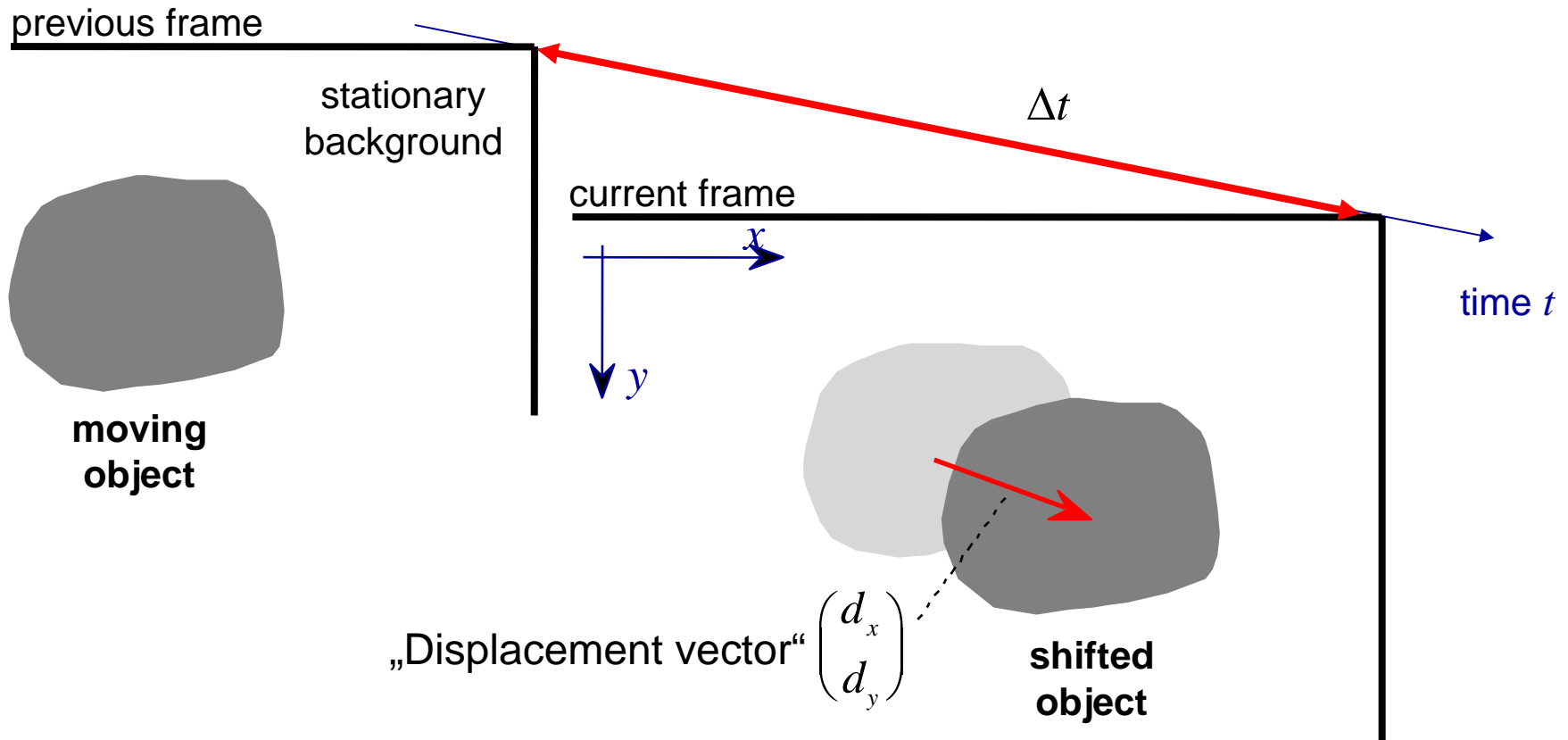

Prediction for the luminance signal  $S(x, y, t)$  within the moving object:

$$\hat{S}(x, y, t) = S(x - d_x, y - d_y, t - \Delta t)$$



# Combining transform coding and prediction

Transform domain prediction

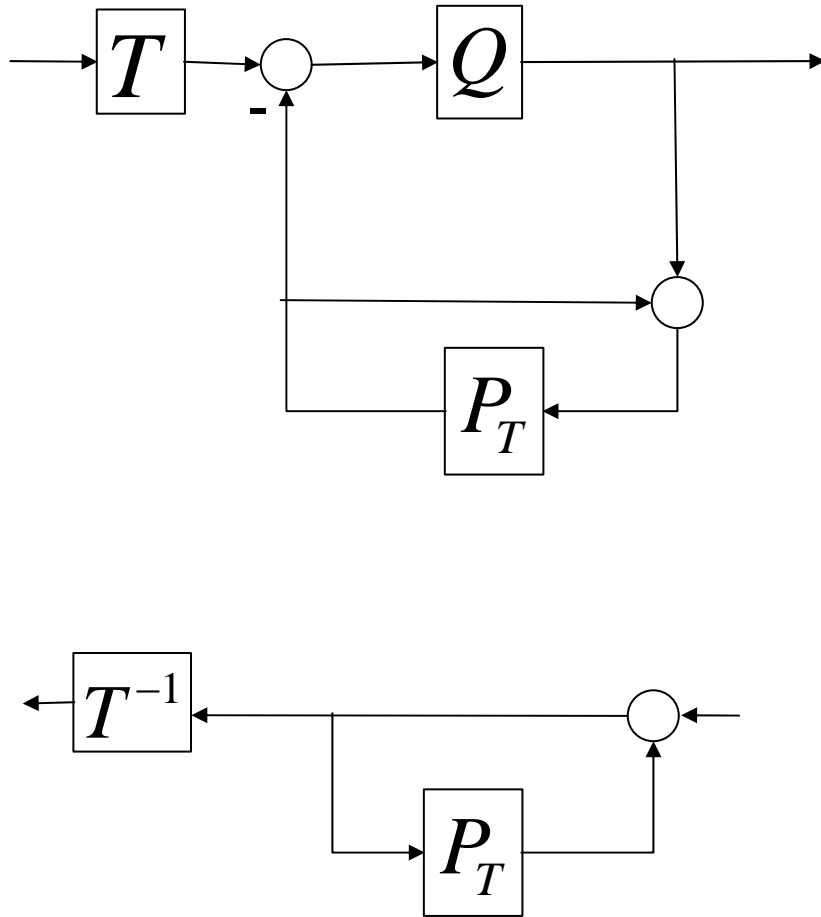

Space domain prediction

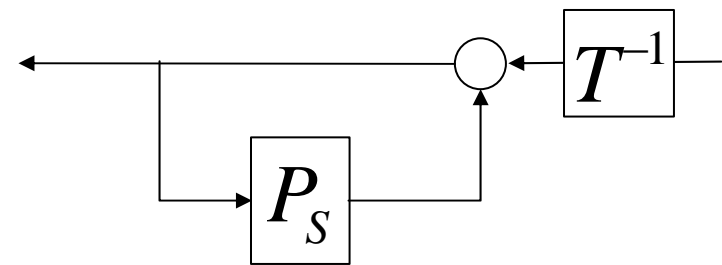

# Motion-compensated hybrid coder

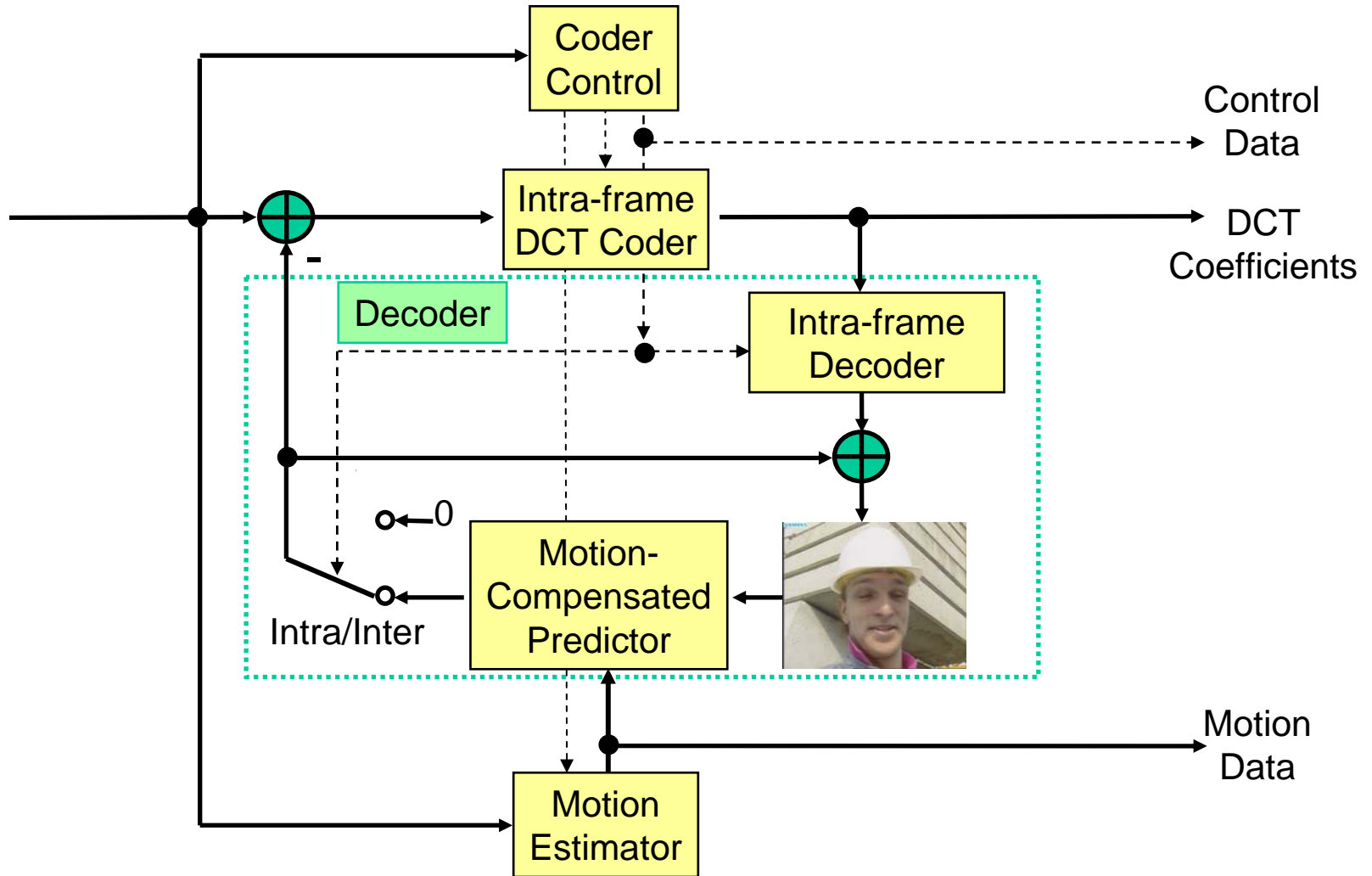

# Motion-compensated hybrid decoder

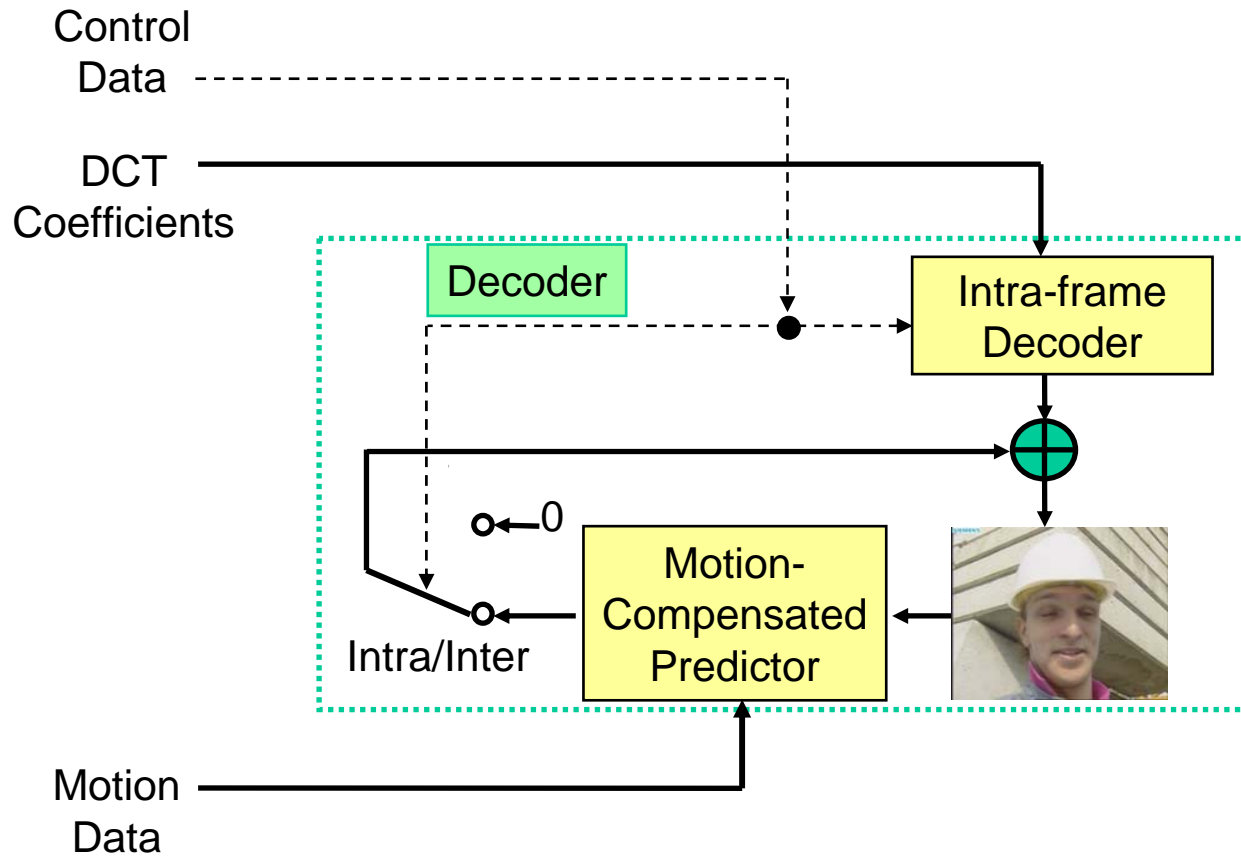

# Reading

---

- B. Girod, H. Almer, L. Bengtsson, B. Christensson, P. Weiss, “A Subjective Evaluation of Noise-Shaping Quantization for Adaptive Intra-/Interframe DPCM Coding of Color Television Signals,” *IEEE Trans. Communications*, vol. 36, no. 3, pp. 332-346, March 1988.
- B. Haskell, P. Gordon, R. Schmidt, J. Scattaglia, “Interframe Coding of 525-Line, Monochrome Television at 1.5 Mbits/s,” *IEEE Trans. Communications*, vol. 25, no. 11, pp. 1339-1348, Nov. 1977.
- S. Ericsson, “Fixed and Adaptive Predictors for Hybrid Predictive/Transform Coding,” *IEEE Trans. Communications*, vol. 33, no. 12, pp. 1291-1302, Dec. 1985.

