

# Lecture 11

## Eigenvectors and diagonalization

- eigenvectors
- dynamic interpretation: invariant sets
- complex eigenvectors & invariant planes
- left eigenvectors
- diagonalization
- modal form
- discrete-time stability

# Eigenvectors and eigenvalues

$\lambda \in \mathbf{C}$  is an *eigenvalue* of  $A \in \mathbf{C}^{n \times n}$  if

$$\mathcal{X}(\lambda) = \det(\lambda I - A) = 0$$

equivalent to:

- there exists nonzero  $v \in \mathbf{C}^n$  s.t.  $(\lambda I - A)v = 0$ , *i.e.*,

$$Av = \lambda v$$

any such  $v$  is called an *eigenvector* of  $A$  (associated with eigenvalue  $\lambda$ )

- there exists nonzero  $w \in \mathbf{C}^n$  s.t.  $w^T(\lambda I - A) = 0$ , *i.e.*,

$$w^T A = \lambda w^T$$

any such  $w$  is called a *left eigenvector* of  $A$

- if  $v$  is an eigenvector of  $A$  with eigenvalue  $\lambda$ , then so is  $\alpha v$ , for any  $\alpha \in \mathbf{C}$ ,  $\alpha \neq 0$
- even when  $A$  is real, eigenvalue  $\lambda$  and eigenvector  $v$  can be complex
- when  $A$  and  $\lambda$  are real, we can always find a real eigenvector  $v$  associated with  $\lambda$ : if  $Av = \lambda v$ , with  $A \in \mathbf{R}^{n \times n}$ ,  $\lambda \in \mathbf{R}$ , and  $v \in \mathbf{C}^n$ , then

$$A\Re v = \lambda\Re v, \quad A\Im v = \lambda\Im v$$

so  $\Re v$  and  $\Im v$  are real eigenvectors, if they are nonzero (and at least one is)

- *conjugate symmetry*: if  $A$  is real and  $v \in \mathbf{C}^n$  is an eigenvector associated with  $\lambda \in \mathbf{C}$ , then  $\bar{v}$  is an eigenvector associated with  $\bar{\lambda}$ : taking conjugate of  $Av = \lambda v$  we get  $\overline{Av} = \overline{\lambda v}$ , so

$$A\bar{v} = \bar{\lambda}\bar{v}$$

**we'll assume  $A$  is real from now on . . .**

# Scaling interpretation

(assume  $\lambda \in \mathbf{R}$  for now; we'll consider  $\lambda \in \mathbf{C}$  later)

if  $v$  is an eigenvector, effect of  $A$  on  $v$  is very simple: scaling by  $\lambda$

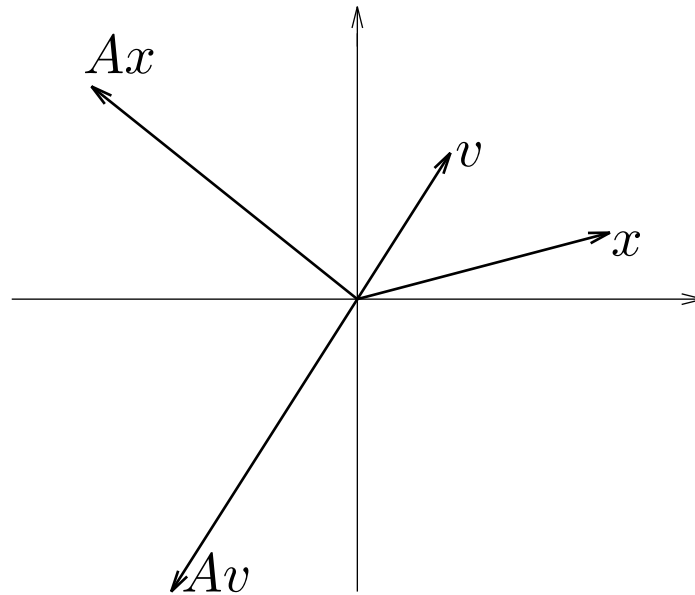

(what is  $\lambda$  here?)

- $\lambda \in \mathbf{R}, \lambda > 0$ :  $v$  and  $Av$  point in same direction
- $\lambda \in \mathbf{R}, \lambda < 0$ :  $v$  and  $Av$  point in opposite directions
- $\lambda \in \mathbf{R}, |\lambda| < 1$ :  $Av$  smaller than  $v$
- $\lambda \in \mathbf{R}, |\lambda| > 1$ :  $Av$  larger than  $v$

(we'll see later how this relates to stability of continuous- and discrete-time systems. . . )

## Dynamic interpretation

suppose  $Av = \lambda v$ ,  $v \neq 0$

if  $\dot{x} = Ax$  and  $x(0) = v$ , then  $x(t) = e^{\lambda t}v$

several ways to see this, *e.g.*,

$$\begin{aligned}x(t) = e^{tA}v &= \left( I + tA + \frac{(tA)^2}{2!} + \dots \right) v \\ &= v + \lambda tv + \frac{(\lambda t)^2}{2!}v + \dots \\ &= e^{\lambda t}v\end{aligned}$$

(since  $(tA)^k v = (\lambda t)^k v$ )

- for  $\lambda \in \mathbf{C}$ , solution is complex (we'll interpret later); for now, assume  $\lambda \in \mathbf{R}$
- if initial state is an eigenvector  $v$ , resulting motion is very simple — always on the line spanned by  $v$
- solution  $x(t) = e^{\lambda t}v$  is called *mode* of system  $\dot{x} = Ax$  (associated with eigenvalue  $\lambda$ )
  
- for  $\lambda \in \mathbf{R}$ ,  $\lambda < 0$ , mode contracts or shrinks as  $t \uparrow$
- for  $\lambda \in \mathbf{R}$ ,  $\lambda > 0$ , mode expands or grows as  $t \uparrow$

# Invariant sets

a set  $S \subseteq \mathbf{R}^n$  is *invariant* under  $\dot{x} = Ax$  if whenever  $x(t) \in S$ , then  $x(\tau) \in S$  for all  $\tau \geq t$

*i.e.*: once trajectory enters  $S$ , it stays in  $S$

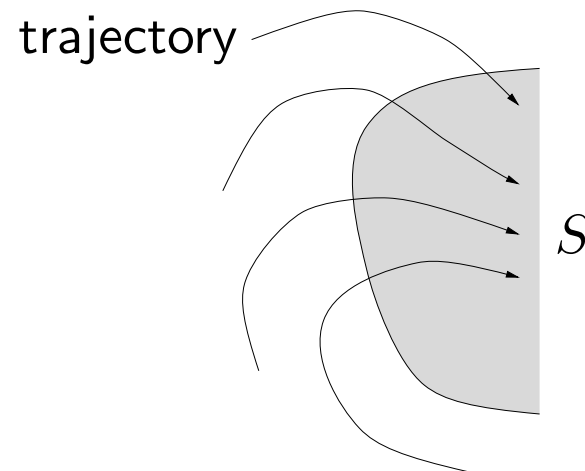

**vector field interpretation:** trajectories only cut *into*  $S$ , never out

suppose  $Av = \lambda v$ ,  $v \neq 0$ ,  $\lambda \in \mathbf{R}$

- line  $\{ tv \mid t \in \mathbf{R} \}$  is invariant  
(in fact, ray  $\{ tv \mid t > 0 \}$  is invariant)
- if  $\lambda < 0$ , line segment  $\{ tv \mid 0 \leq t \leq a \}$  is invariant

## Complex eigenvectors

suppose  $Av = \lambda v$ ,  $v \neq 0$ ,  $\lambda$  is complex

for  $a \in \mathbf{C}$ , (complex) trajectory  $ae^{\lambda t}v$  satisfies  $\dot{x} = Ax$

hence so does (real) trajectory

$$\begin{aligned}x(t) &= \Re(ae^{\lambda t}v) \\ &= e^{\sigma t} \begin{bmatrix} v_{\text{re}} & v_{\text{im}} \end{bmatrix} \begin{bmatrix} \cos \omega t & \sin \omega t \\ -\sin \omega t & \cos \omega t \end{bmatrix} \begin{bmatrix} \alpha \\ -\beta \end{bmatrix}\end{aligned}$$

where

$$v = v_{\text{re}} + jv_{\text{im}}, \quad \lambda = \sigma + j\omega, \quad a = \alpha + j\beta$$

- trajectory stays in *invariant plane*  $\text{span}\{v_{\text{re}}, v_{\text{im}}\}$
- $\sigma$  gives logarithmic growth/decay factor
- $\omega$  gives angular velocity of rotation in plane

## Dynamic interpretation: left eigenvectors

suppose  $w^T A = \lambda w^T$ ,  $w \neq 0$

then

$$\frac{d}{dt}(w^T x) = w^T \dot{x} = w^T A x = \lambda(w^T x)$$

*i.e.*,  $w^T x$  satisfies the DE  $d(w^T x)/dt = \lambda(w^T x)$

hence  $w^T x(t) = e^{\lambda t} w^T x(0)$

- even if trajectory  $x$  is complicated,  $w^T x$  is simple
- if, *e.g.*,  $\lambda \in \mathbf{R}$ ,  $\lambda < 0$ , halfspace  $\{ z \mid w^T z \leq a \}$  is invariant (for  $a \geq 0$ )
- for  $\lambda = \sigma + j\omega \in \mathbf{C}$ ,  $(\Re w)^T x$  and  $(\Im w)^T x$  both have form

$$e^{\sigma t} (\alpha \cos(\omega t) + \beta \sin(\omega t))$$

# Summary

- *right eigenvectors* are initial conditions from which resulting motion is simple (*i.e.*, remains on line or in plane)
- *left eigenvectors* give linear functions of state that are simple, for any initial condition

**example 1:**  $\dot{x} = \begin{bmatrix} -1 & -10 & -10 \\ 1 & 0 & 0 \\ 0 & 1 & 0 \end{bmatrix} x$

block diagram:

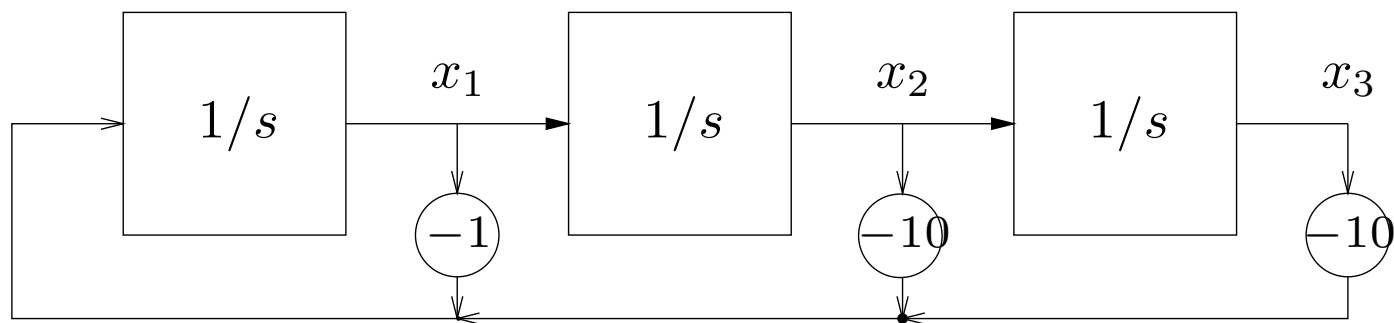

$$\mathcal{X}(s) = s^3 + s^2 + 10s + 10 = (s + 1)(s^2 + 10)$$

eigenvalues are  $-1, \pm j\sqrt{10}$

trajectory with  $x(0) = (0, -1, 1)$ :

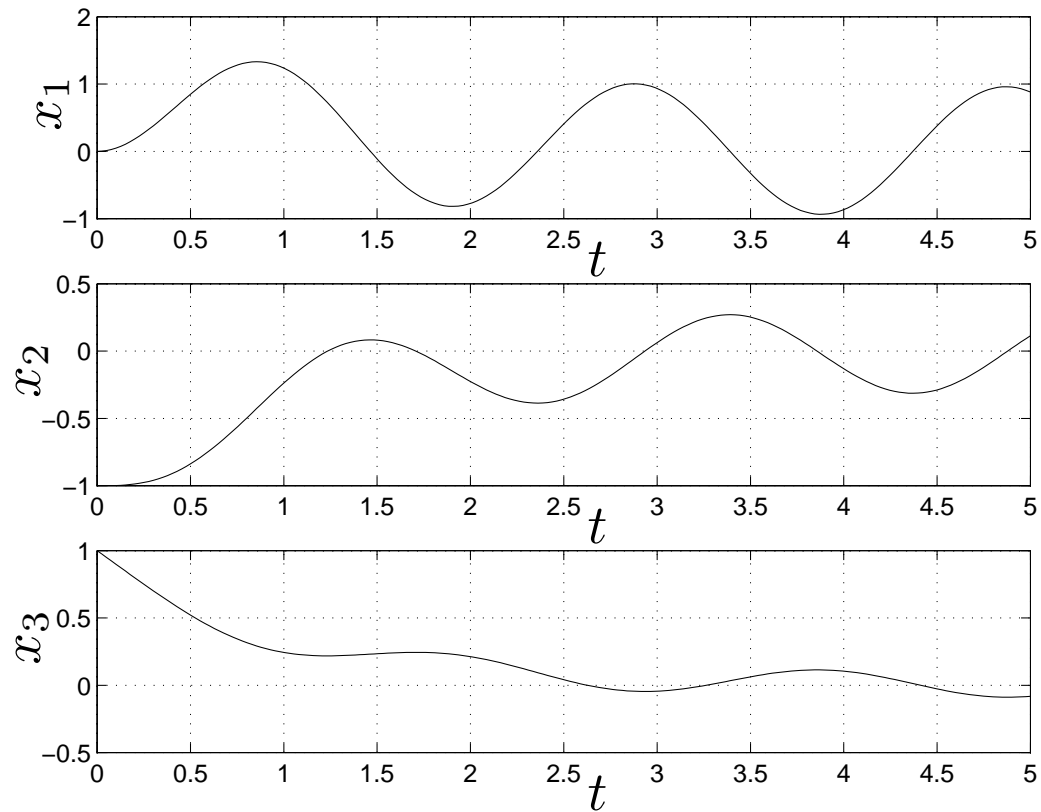

left eigenvector associated with eigenvalue  $-1$  is

$$g = \begin{bmatrix} 0.1 \\ 0 \\ 1 \end{bmatrix}$$

let's check  $g^T x(t)$  when  $x(0) = (0, -1, 1)$  (as above):

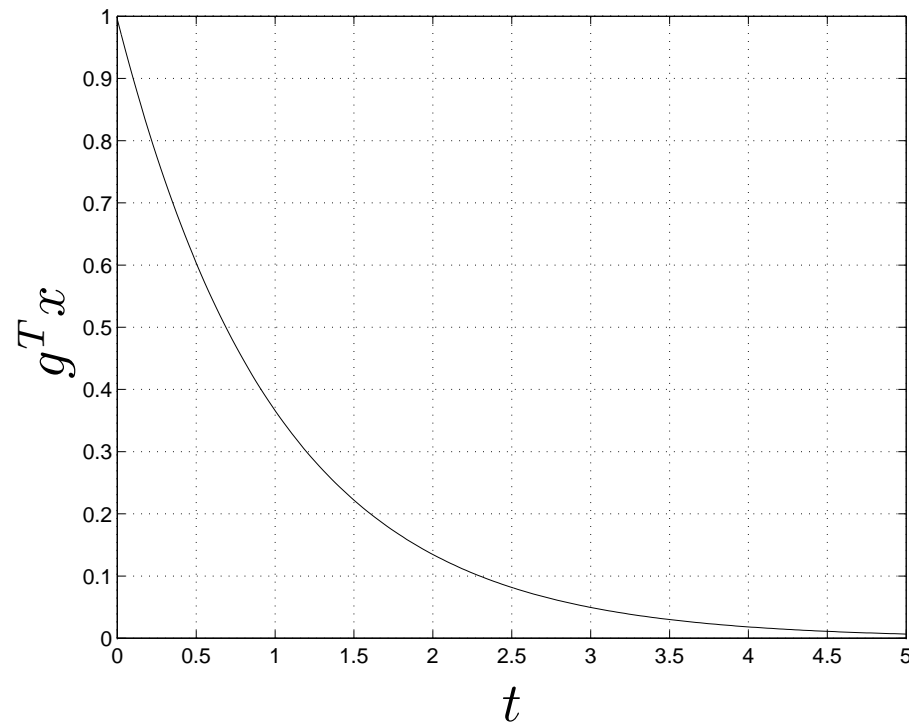

eigenvector associated with eigenvalue  $j\sqrt{10}$  is

$$v = \begin{bmatrix} -0.554 + j0.771 \\ 0.244 + j0.175 \\ 0.055 - j0.077 \end{bmatrix}$$

so an invariant plane is spanned by

$$v_{\text{re}} = \begin{bmatrix} -0.554 \\ 0.244 \\ 0.055 \end{bmatrix}, \quad v_{\text{im}} = \begin{bmatrix} 0.771 \\ 0.175 \\ -0.077 \end{bmatrix}$$

for example, with  $x(0) = v_{re}$  we have

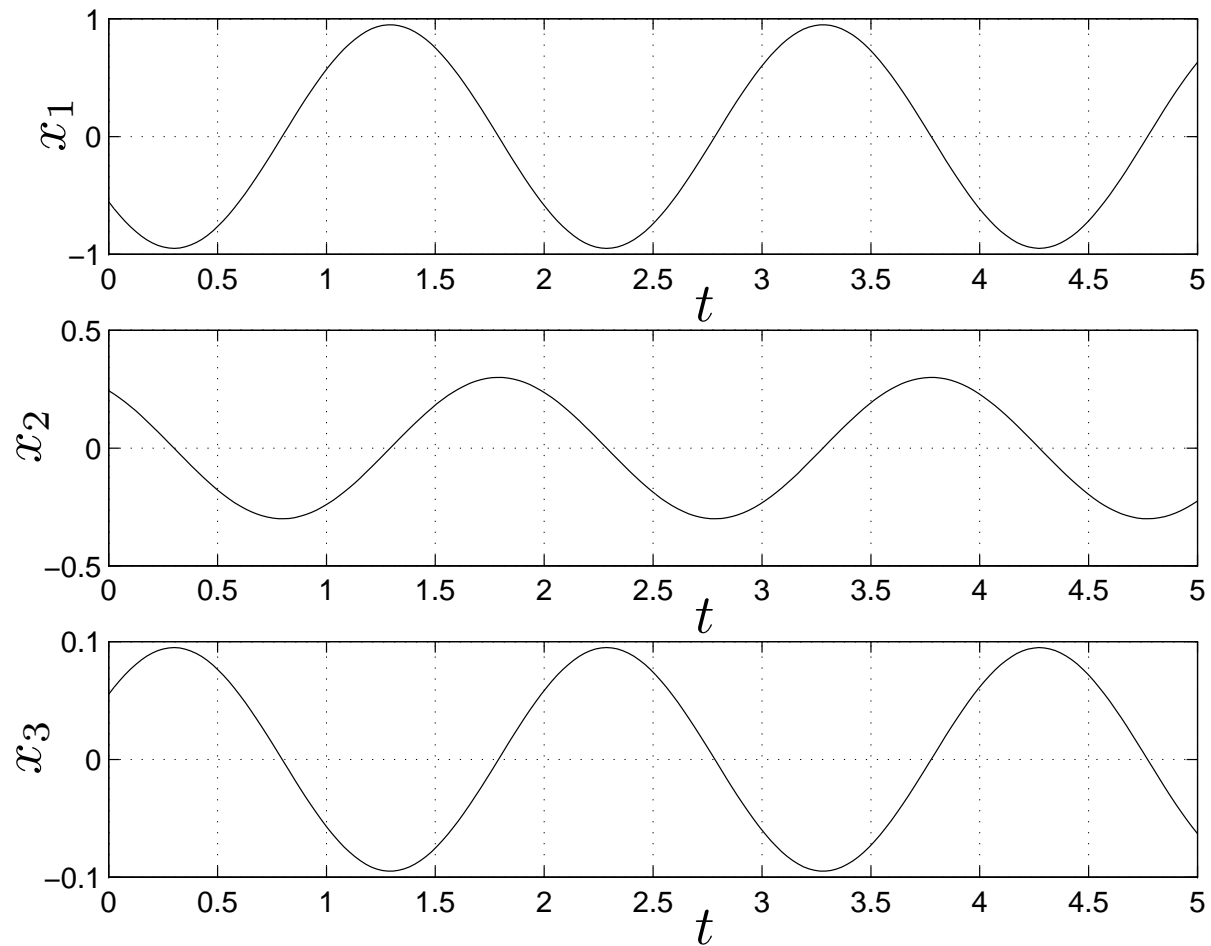

## Example 2: Markov chain

probability distribution satisfies  $p(t + 1) = Pp(t)$

$p_i(t) = \mathbf{Prob}( z(t) = i )$  so  $\sum_{i=1}^n p_i(t) = 1$

$P_{ij} = \mathbf{Prob}( z(t + 1) = i \mid z(t) = j )$ , so  $\sum_{i=1}^n P_{ij} = 1$   
(such matrices are called *stochastic*)

rewrite as:

$$[1 \ 1 \ \cdots \ 1]P = [1 \ 1 \ \cdots \ 1]$$

*i.e.*,  $[1 \ 1 \ \cdots \ 1]$  is a left eigenvector of  $P$  with e.v. 1

hence  $\det(I - P) = 0$ , so there is a right eigenvector  $v \neq 0$  with  $Pv = v$

it can be shown that  $v$  can be chosen so that  $v_i \geq 0$ , hence we can normalize  $v$  so that  $\sum_{i=1}^n v_i = 1$

**interpretation:**  $v$  is an *equilibrium distribution*; *i.e.*, if  $p(0) = v$  then  $p(t) = v$  for all  $t \geq 0$

(if  $v$  is unique it is called the *steady-state distribution* of the Markov chain)

# Diagonalization

suppose  $v_1, \dots, v_n$  is a *linearly independent* set of eigenvectors of  $A \in \mathbf{R}^{n \times n}$ :

$$Av_i = \lambda_i v_i, \quad i = 1, \dots, n$$

express as

$$A \begin{bmatrix} v_1 & \cdots & v_n \end{bmatrix} = \begin{bmatrix} v_1 & \cdots & v_n \end{bmatrix} \begin{bmatrix} \lambda_1 & & \\ & \cdots & \\ & & \lambda_n \end{bmatrix}$$

define  $T = \begin{bmatrix} v_1 & \cdots & v_n \end{bmatrix}$  and  $\Lambda = \mathbf{diag}(\lambda_1, \dots, \lambda_n)$ , so

$$AT = T\Lambda$$

and finally

$$T^{-1}AT = \Lambda$$

- $T$  invertible since  $v_1, \dots, v_n$  linearly independent
- similarity transformation by  $T$  diagonalizes  $A$

conversely if there is a  $T = [v_1 \ \cdots \ v_n]$  s.t.

$$T^{-1}AT = \Lambda = \mathbf{diag}(\lambda_1, \dots, \lambda_n)$$

then  $AT = T\Lambda$ , *i.e.*,

$$Av_i = \lambda_i v_i, \quad i = 1, \dots, n$$

so  $v_1, \dots, v_n$  is a linearly independent set of  $n$  eigenvectors of  $A$

we say  $A$  is *diagonalizable* if

- there exists  $T$  s.t.  $T^{-1}AT = \Lambda$  is diagonal
- $A$  has a set of  $n$  linearly independent eigenvectors

(if  $A$  is not diagonalizable, it is sometimes called *defective*)

## Not all matrices are diagonalizable

**example:**  $A = \begin{bmatrix} 0 & 1 \\ 0 & 0 \end{bmatrix}$

characteristic polynomial is  $\mathcal{X}(s) = s^2$ , so  $\lambda = 0$  is only eigenvalue

eigenvectors satisfy  $Av = 0v = 0$ , *i.e.*

$$\begin{bmatrix} 0 & 1 \\ 0 & 0 \end{bmatrix} \begin{bmatrix} v_1 \\ v_2 \end{bmatrix} = 0$$

so all eigenvectors have form  $v = \begin{bmatrix} v_1 \\ 0 \end{bmatrix}$  where  $v_1 \neq 0$

thus,  $A$  cannot have two independent eigenvectors

## Distinct eigenvalues

**fact:** if  $A$  has distinct eigenvalues, *i.e.*,  $\lambda_i \neq \lambda_j$  for  $i \neq j$ , then  $A$  is diagonalizable

(the converse is false —  $A$  can have repeated eigenvalues but still be diagonalizable)

## Diagonalization and left eigenvectors

rewrite  $T^{-1}AT = \Lambda$  as  $T^{-1}A = \Lambda T^{-1}$ , or

$$\begin{bmatrix} w_1^T \\ \vdots \\ w_n^T \end{bmatrix} A = \Lambda \begin{bmatrix} w_1^T \\ \vdots \\ w_n^T \end{bmatrix}$$

where  $w_1^T, \dots, w_n^T$  are the rows of  $T^{-1}$

thus

$$w_i^T A = \lambda_i w_i^T$$

*i.e.*, the rows of  $T^{-1}$  are (lin. indep.) left eigenvectors, normalized so that

$$w_i^T v_j = \delta_{ij}$$

(*i.e.*, left & right eigenvectors chosen this way are *dual bases*)

# Modal form

suppose  $A$  is diagonalizable by  $T$

define new coordinates by  $x = T\tilde{x}$ , so

$$T\dot{\tilde{x}} = AT\tilde{x} \quad \Leftrightarrow \quad \dot{\tilde{x}} = T^{-1}AT\tilde{x} \quad \Leftrightarrow \quad \dot{\tilde{x}} = \Lambda\tilde{x}$$

in new coordinate system, system is diagonal (decoupled):

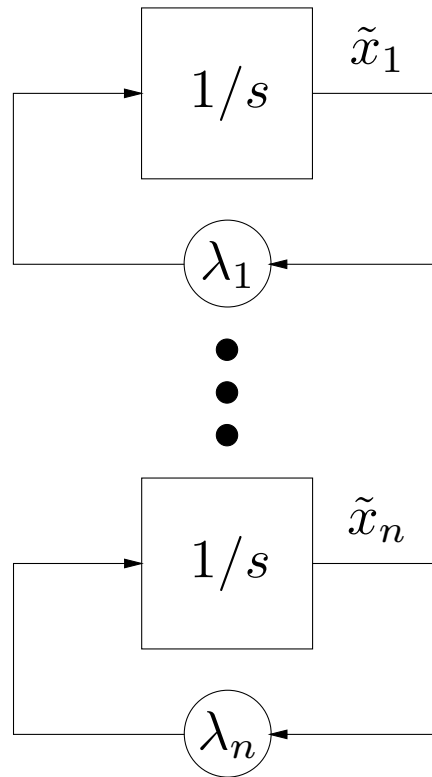

trajectories consist of  $n$  independent modes, *i.e.*,

$$\tilde{x}_i(t) = e^{\lambda_i t} \tilde{x}_i(0)$$

hence the name *modal form*

# Real modal form

when eigenvalues (hence  $T$ ) are complex, system can be put in *real modal form*:

$$S^{-1}AS = \mathbf{diag}(\Lambda_r, M_{r+1}, M_{r+3}, \dots, M_{n-1})$$

where  $\Lambda_r = \mathbf{diag}(\lambda_1, \dots, \lambda_r)$  are the real eigenvalues, and

$$M_i = \begin{bmatrix} \sigma_i & \omega_i \\ -\omega_i & \sigma_i \end{bmatrix}, \quad \lambda_i = \sigma_i + j\omega_i, \quad i = r+1, r+3, \dots, n$$

where  $\lambda_i$  are the complex eigenvalues (one from each conjugate pair)

block diagram of 'complex mode':

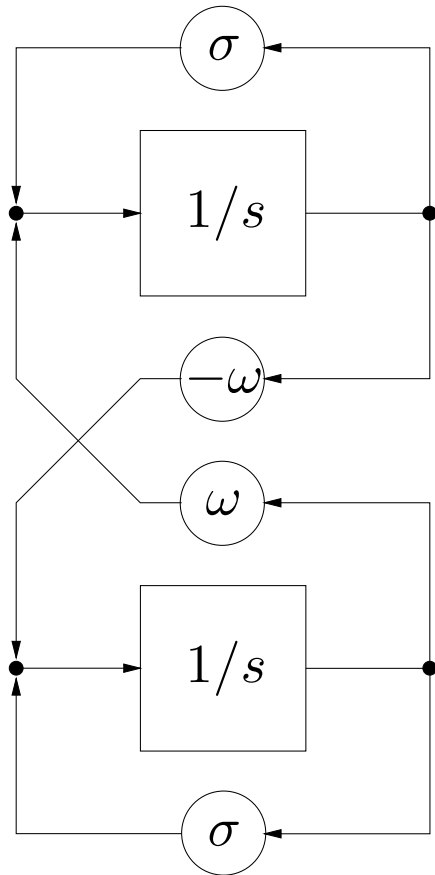

diagonalization simplifies many matrix expressions

*e.g.*, resolvent:

$$\begin{aligned}(sI - A)^{-1} &= (sTT^{-1} - T\Lambda T^{-1})^{-1} \\ &= (T(sI - \Lambda)T^{-1})^{-1} \\ &= T(sI - \Lambda)^{-1}T^{-1} \\ &= T \mathbf{diag} \left( \frac{1}{s - \lambda_1}, \dots, \frac{1}{s - \lambda_n} \right) T^{-1}\end{aligned}$$

powers (*i.e.*, discrete-time solution):

$$\begin{aligned}A^k &= (T\Lambda T^{-1})^k \\ &= (T\Lambda T^{-1}) \cdots (T\Lambda T^{-1}) \\ &= T\Lambda^k T^{-1} \\ &= T \mathbf{diag}(\lambda_1^k, \dots, \lambda_n^k) T^{-1}\end{aligned}$$

(for  $k < 0$  only if  $A$  invertible, *i.e.*, all  $\lambda_i \neq 0$ )

exponential (*i.e.*, continuous-time solution):

$$\begin{aligned} e^A &= I + A + A^2/2! + \dots \\ &= I + T\Lambda T^{-1} + (T\Lambda T^{-1})^2 / 2! + \dots \\ &= T(I + \Lambda + \Lambda^2/2! + \dots)T^{-1} \\ &= Te^{\Lambda}T^{-1} \\ &= T \mathbf{diag}(e^{\lambda_1}, \dots, e^{\lambda_n})T^{-1} \end{aligned}$$

## Analytic function of a matrix

for any analytic function  $f : \mathbf{R} \rightarrow \mathbf{R}$ , *i.e.*, given by power series

$$f(a) = \beta_0 + \beta_1 a + \beta_2 a^2 + \beta_3 a^3 + \dots$$

we can define  $f(A)$  for  $A \in \mathbf{R}^{n \times n}$  (*i.e.*, overload  $f$ ) as

$$f(A) = \beta_0 I + \beta_1 A + \beta_2 A^2 + \beta_3 A^3 + \dots$$

substituting  $A = T\Lambda T^{-1}$ , we have

$$\begin{aligned} f(A) &= \beta_0 I + \beta_1 A + \beta_2 A^2 + \beta_3 A^3 + \dots \\ &= \beta_0 T T^{-1} + \beta_1 T \Lambda T^{-1} + \beta_2 (T \Lambda T^{-1})^2 + \dots \\ &= T (\beta_0 I + \beta_1 \Lambda + \beta_2 \Lambda^2 + \dots) T^{-1} \\ &= T \mathbf{diag}(f(\lambda_1), \dots, f(\lambda_n)) T^{-1} \end{aligned}$$

## Solution via diagonalization

assume  $A$  is diagonalizable

consider LDS  $\dot{x} = Ax$ , with  $T^{-1}AT = \Lambda$

then

$$\begin{aligned}x(t) &= e^{tA}x(0) \\ &= Te^{\Lambda t}T^{-1}x(0) \\ &= \sum_{i=1}^n e^{\lambda_i t} (w_i^T x(0)) v_i\end{aligned}$$

thus: any trajectory can be expressed as linear combination of modes

## interpretation:

- (left eigenvectors) decompose initial state  $x(0)$  into modal components  $w_i^T x(0)$
- $e^{\lambda_i t}$  term propagates  $i$ th mode forward  $t$  seconds
- reconstruct state as linear combination of (right) eigenvectors

**application:** for what  $x(0)$  do we have  $x(t) \rightarrow 0$  as  $t \rightarrow \infty$ ?

divide eigenvalues into those with negative real parts

$$\Re\lambda_1 < 0, \dots, \Re\lambda_s < 0,$$

and the others,

$$\Re\lambda_{s+1} \geq 0, \dots, \Re\lambda_n \geq 0$$

from

$$x(t) = \sum_{i=1}^n e^{\lambda_i t} (w_i^T x(0)) v_i$$

condition for  $x(t) \rightarrow 0$  is:

$$x(0) \in \text{span}\{v_1, \dots, v_s\},$$

or equivalently,

$$w_i^T x(0) = 0, \quad i = s + 1, \dots, n$$

(can you prove this?)

# Stability of discrete-time systems

suppose  $A$  diagonalizable

consider discrete-time LDS  $x(t + 1) = Ax(t)$

if  $A = T\Lambda T^{-1}$ , then  $A^k = T\Lambda^k T^{-1}$

then

$$x(t) = A^t x(0) = \sum_{i=1}^n \lambda_i^t (w_i^T x(0)) v_i \rightarrow 0 \quad \text{as } t \rightarrow \infty$$

for all  $x(0)$  if and only if

$$|\lambda_i| < 1, \quad i = 1, \dots, n.$$

we will see later that this is true even when  $A$  is not diagonalizable, so we have

**fact:**  $x(t + 1) = Ax(t)$  is stable if and only if all eigenvalues of  $A$  have magnitude less than one