

## EE183 LAB 3

### 12-bit RISC Microprocessor

#### Purpose

The third project consists of implementing a pipelined processor. This project illustrates many of the datapath and control design issues you have faced in the previous projects. It is complex enough to be interesting, but simple enough to be done in two weeks.

#### Assignment

Here are the requirements:

1. Design and implement your processor on one Xilinx FPGA.
2. Demonstrate your working processor by running our test programs and showing the key results either on the VGA display or the 7-segment LED.
3. Add a memory-mapped VGA graphics device.
4. Add a timer either as an external condition or a memory-mapped device.
5. Write a test program of your own which draws to the VGA device in an “interesting” manner using the timer.
6. Demonstrate your working processor by running your test programs.
7. Turn in a write-up.

#### System Description

There are three main parts to the design: 1) the processor, 2) the instruction ROM, 3) the data RAM. The processor is the only part that you will have to design; the other two parts are generated from CoreGen. Details about each part will follow. Below is a description of the primary inputs and outputs of the system. Figure 6 shows the block diagram of this system. (Note that the memory-mapped VGA interface and timer interface are not shown in this diagram.)

Figure 1: System Block Diagram

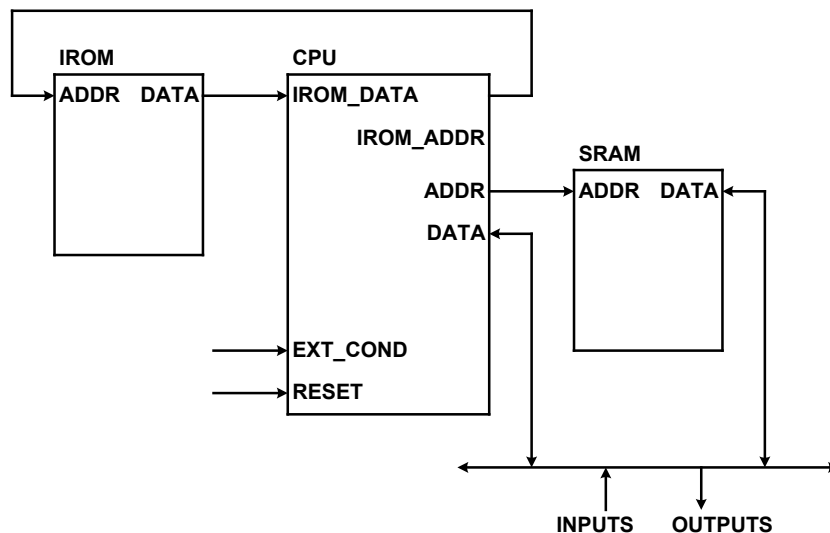

#### Primary Inputs

CLK	System clock
EXT_COND	Pushbutton which specifies an external condition for conditional branches.
SW_DATA[11:0]	Set of external switches for data input to the processor.

### **The Processor**

The processor is to be designed by you. You must follow the specifications exactly so that programs written for this instruction set will run on your completed hardware. In other words, you cannot modify the instruction set architecture.

The entire processor must fit on a single FPGA. There is plenty of room to fit everything if you are efficient, but a careless design may overflow the part. The boolean part of the ALU, the register file, and the top-level pipeline stages with a crude memory-mapped input for the DIP switches are provided. Be sure to look at all the files we give you so you don't re-implement these. You must fill in the rest. (That basically means the PC and jump control, the ALU logic and muxes, the write-back logic, and the forwarding logic.)

### **The Instruction ROM**

The instruction ROM is emulated in the FPGA. We will be using the Xilinx CORE generator to create this element. A sample IROM is included in the starter files (but may be out-of-date), but you will have to generate a separate IROM for each program you wish to run. To load a program into the ROM you first need to compile it from assembly using the provided `asm183.pl` assembler running in Perl. This will work on any unix machine or under windows if Perl is installed. Once you have run the assembler simply load the generated `.coe` file as the default values for your IROM to run the program. Note that the ROM generated by the CORE Generator is pipelined and provides the data on the following clock edge. This means that the address provided in the I stage will yield corresponding data at the beginning of the R stage. (In effect you already have one of your pipeline registers built in to the IROM.)

### **The Data RAM**

The data RAM is a 12-bit wide memory that you can implement using a CORE Generator module. This module has been provided for you in the starter files (but may be out-of-date). It is worth noting that this device is synchronous so the output data for a read operation is available on the following clock edge. This means that if you provide the address in the E stage the data is not ready until the W stage. (Again this means you've in effect got one of your pipeline registers built in to the RAM.)

### **Important notes**

- Make sure that you switch out the ROMs when you want to run a different program. This means you will have to generate a separate bit file for each program. When you are ready to demo it would be nice to have all of these generated and ready to display at once.
- You will need to devise a method for displaying your results to the outside world. For the provided test programs it is best to hack the register file to get the appropriate register to display on the LEDs.
- Remember that the VGA runs at 50MHz. You can get your whole design running at 50MHz but it will be hard. We expect you to get it running at at least 25MHz (you can divide the clock down for everything but the VGA), but below that is not good.

### **Processor Description**

Figure 2 shows a block diagram of the processor you are to design. The top level schematic of the processor is very similar to the block diagram.

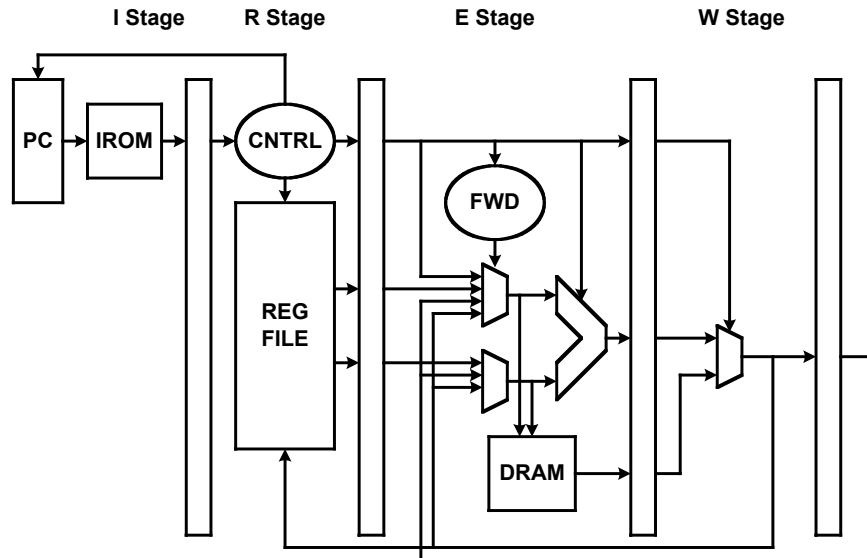

**Figure 2: Processor Block Diagram**

The processor you are to design is a 12-bit RISC microprocessor. It features 8 general purpose registers, 43 instructions, and a 4 stage pipeline. The external interface signals are listed below. You will be provided with a "template" schematic for the processor design which contains the pipeline registers and the DIP switch inputs.

CPU_IROM_ADDR_I[11:0]	This output is the address of the instruction to be fetched from the IROM.
IROM_CPU_DATA_D[15:0]	This input is the instruction word at the address specified by IROM_ADDR[11:0].
CPU_DRAM_ADDR_E[11:0]	This output is the address of the data RAM location being accessed.
CPU_DRAM_DATA_E[11:0]	This is the data to be written on a STORE
DRAM_CPU_DATA_M[11:0]	This is the data that has been read on a LOAD
DRAM_WE	This output is the data RAM write enable.
CLK	This input is the system clock
EXT_COND	This input specifies an external condition for conditional branches.
RESET	This input sets the PC to zero and clears out all the pipeline flops.

## Instruction Set

Several fields occur frequently in the instruction set encodings. These fields are the destination register (WC), the A source register (RA), and the B source register (RB). The interpretation of other fields depends on the instruction class.

### ALU Instruction Format

15	14	13	12	11	10	9	8	7	6	5	4	3	2	1	0
0	1														
0	1	WC			OP				RA			RB			

### ALU Instructions

<u>OP Field</u>	<u>Operation</u>	<u>Mnemonic</u>	
00	$C = A + B$	ADD	C, A, B
01	$C = A + B + 1$	ADDINC	C, A, B
02	$C = A$	PASSA	C, A
03	$C = A + 1$	INCA	C, A
04	$C = A - B - 1$	SUBDEC	C, A, B
05	$C = A - B$	SUB	C, A, B
06	$C = A - 1$	DECA	C, A
07	$C = A$	PASSA	C, A
08	$C = \text{Logical Shift Left (A)}$	LSL	C, A
09	$C = \text{Arithmetic Shift Right (A)}$	ASR	C, A
10	$C = 0$	ZEROES	C
11	$C = A \cdot B$	AND	C, A, B
12	$C = A' \cdot B$	ANDNOTA	C, A, B
13	$C = B$	PASSB	C, B
14	$C = A \cdot B'$	ANDNOTB	C, A, B
15	$C = A$	PASSA	C, A
16	$C = A \text{ xor } B$	XOR	C, A, B
17	$C = A + B$	OR	C, A, B
18	$C = A' \cdot B'$	NOR	C, A, B
19	$C = A \text{ xor } B'$	XNOR	C, A, B
1A	$C = A'$	PASSNOTA	C, A
1B	$C = A' + B$	ORNOTA	C, A, B
1C	$C = B'$	PASSNOTB	C, B
1D	$C = A + B'$	ORNOTB	C, A, B
1E	$C = A' + B'$	NAND	C, A, B
1F	$C = 1$	ONES	C

Note that the Boolean section (0x10 through 0x1F) is provided for you in the bool.v file. Take a look at how efficient it is. Also, please note that there is a very regular pattern in the arithmetic instructions. For example, every instruction which has a +1 on it also has the LSB of the OP Field set to 1. Since your critical path will probably go through the ALU it would be worth your time to consider optimizing this part of the data path with the above in mind.

### Literal Instruction Format

15	14	13	12	11	10	9	8	7	6	5	4	3	2	1	0
1															
1	L	WC			LITERAL										

**Literal Instruction**

<u>OP Field</u>	<u>Operation</u>	<u>Mnemonic</u>	
1	C = literal	LOADLIT	C, literal

In the literal instruction, the literal data is not in a contiguous bit field. The most significant bit of the literal is in the L field. Originally this instruction only supported 8-bit literals, but it was extended to 12 bits to make it more useful.

**Memory Instruction Format**

15	14	13	12	11	10	9	8	7	6	5	4	3	2	1	0
0	1														
0	1	WC			OP				RA			RB			

**Memory Instructions**

<u>OP Field</u>	<u>Operation</u>	<u>Mnemonic</u>	
0A	C = Mem[A]	LOAD	C, A
0B	Mem[A] = B	STORE	A,B

**Control Transfer Instruction Formats**

15	14	13	12	11	10	9	8	7	6	5	4	3	2	1	0
0	0														
0		OP		COND				JUMP ADDRESS							

15	14	13	12	11	10	9	8	7	6	5	4	3	2	1	0
0	0														
0		OP		JUMP ADDRESS											

**Control Transfer Instructions**

<u>OP Field</u>	<u>Operation</u>	<u>Mnemonic</u>	
0	Jump false	JF.cond	JPC
1	Jump true	JT.cond	JPC
2	Jump	J	JPC

<u>COND Field</u>	<u>Operation</u>	<u>Mnemonic</u>
0	Always true	.TRUE
4	Result < 0	.NEG
5	Result = 0	.ZERO
6	Carry = 1	.CARRY
7	Result <= 0	.NEGZERO
8	Ext Cond = 1	.EXT

The NOP instruction is implemented by using the jump false on condition true instruction (JF.TRUE). The encoding of this instruction results in an instruction word of all zeros.

Except for the external and always true conditions, the other conditions are set as a result of ALU operations. In your design, assume that conditional jumps always follow an ALU instruction. In other words, you do not need to save the condition codes from the ALU. Placing a conditional jump after a non-ALU instruction will result in unspecified behavior. Avoid this while writing programs.

If you decide to implement the timer as an external condition you will need to decide how to encode it (i.e., as EXT1) above and modify the assembler to include it. If you do it as a memory-mapped device you won't need to do this.

## Hazards Created By Pipelining

In a non-pipelined processor, the execution of each instruction is completed before the next instruction is begun. Consider the cycle diagram for a non-pipelined, multi-cycle version of the processor:

### Cycle number

Instruction i  
Instruction i+1  
Instruction i+2

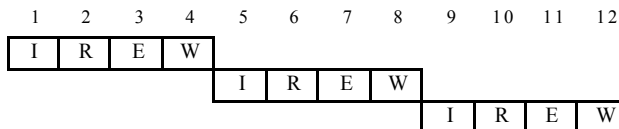

Each instruction takes four cycles to complete, and the machine throughput is 0.25 instructions per cycle. Now consider the cycle diagram for a four-stage pipelined version of the processor (which you will build):

### Cycle number

Instruction i  
Instruction i+1  
Instruction i+2  
Instruction i+3

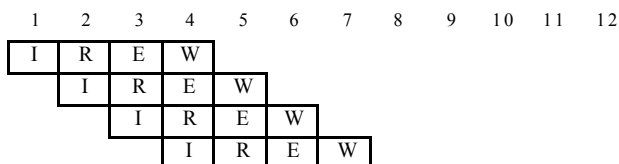

Each instruction still takes four cycles to complete, but the machine throughput is now (ideally) 1.0 instructions per cycle during sustained execution (see cycles 4 and 5). Pipelining improves performance by increasing instruction throughput. This is important because real programs do not consist of three or four instructions, but billions of instructions.

Unfortunately, nothing in this world is free (incidentally, though, pipelining is the closest thing to a free lunch in digital design). By overlapping instruction execution in a pipeline, *hazards* are created. There are two significant types, control hazards and data hazards.

### Control Hazards—Consider the following code fragment:

```

ADD      R1, R2, R3
JT.ZERO  _TAKEN
SUB      R4, R5, R6
AND      R7, R8, R1
...
...
_TAKEN   NOR      R7, R8, R1
    
```

Due to the fact that the condition code (CC) for the conditional jump is not known until the ADD completes the execution stage, the instruction following the conditional jump will enter the pipeline. (Arrow signifies condition code being set)

### Jump Not Taken

#### Cycle number

ADD R1, R2, R3  
JT.ZERO \_TAKEN  
SUB R4, R5, R6  
AND R7, R8, R1

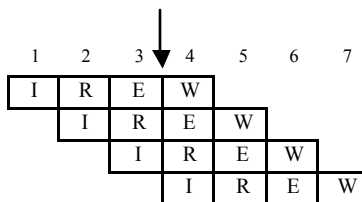

Since the jump was not taken, the instruction following the conditional jump is meant to be executed and is already in the pipeline. This is not a problem.

## Jump Taken

### Cycle number

```
ADD R1, R2, R3
JT.ZERO_TAKEN
SUB R4, R5, R6
NOR R7, R8, R1
```

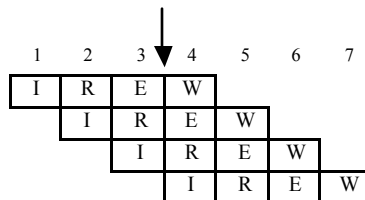

In this case, however, the instruction following the conditional jump is not meant to be executed. There are several ways to deal with this, including flushing the pipeline or inserting bubbles. However, this requires additional control logic. For the purposes of this lab, simply follow all jumps in your program with a NOP instruction. This way, the unwanted execution is harmless.

## Data Hazards

Consider the following code fragment:

```
_START    ADD      R1, R2, R3
          SUB      R4, R1, R5
          NOR      R6, R1, R7
```

This code fragment results in the cycle diagram shown below. Note that the source operand of the SUB and NOR instructions (R1) depends on the result of the ADD instruction.

### Cycle number

```
ADD R1, R2, R3
SUB R4, R1, R5
NOR R6, R1, R7
```

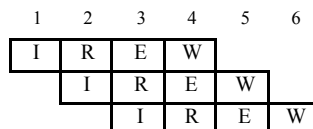

From the above diagram, you can see that the SUB and NOR instructions will attempt to read their operands from the register file in cycles 3 and 4, before the ADD writes back the correct data value into the register file. The data written back by the ADD instruction is not available until the beginning of cycle 5. This will result in incorrect execution of the program.

Conceptually, the write data from the AND must be forwarded to the SUB and NOR instructions to ensure correct execution. Depending on the implementation of the processor, there may be more than one way to achieve this effect. In this implementation of the processor, all data is forwarded to the E stage, as shown in the block diagram of the processor. This requires a copy of the destination register address and data to be saved after the W stage for possible use in the E stage (note the "extra" pipe segment after the W stage in the block diagram).

It is entirely possible to forward from the W stage to the R stage instead of the above arrangement. However, the schematic template you will be given is not arranged this way, so if you implement this method, you will need to alter the template.

Do not forget that the memory instructions also transfer data to and from the register file (in fact, the LOAD and STORE instructions are encoded as ALU operations). You are responsible for implementing complete data forwarding logic so that inserting NOP instructions is not necessary for correct program execution.

## Asm183

You will be provided with a perl script called asm183 which will help you with the task of assembling the programs you write. You could do this by hand using the information you have on the instruction set, but this course of action has been reported to be excessively painful. Since asm183 is written in perl, you can run it anywhere you have access to perl. Invoke asm183 by typing "perl asm183.pl my\_prog.asm". ASM183 provides several output formats. The two that you will find useful are .coe and .lis. The .coe

file can be used by the CORE Generator program to preload your IROM with a program. The .lis file contains the address, machine code, and assembly for each line to make debugging easier to follow.

### **Timer**

The timer is simply a free-running counter which generates a signal every so many cycles. This is used for timing within your code. For example, if you wanted to do an animation every second you could either count 25 million NOPs between each animation or have a free running counter which generated a signal every second and just wait for that signal. You should choose the speed of your counter (extra points for making it programmable if you do it as a memory-mapped I/O device) and decide to either connect it as a second external condition or a memory-mapped device.

### **Memory-mapped I/O**

You are required to add on a memory-mapped VGA display to your processor. This is basically one (or more) BRAMs which draw to the VGA just as in labs 1 and 2, but now you access the by issuing a STORE instruction to a special address. You then have to implement the logic which intercepts that STORE to the special address and disables the WE on the DRAM and instead enables a WE on the VGA's BRAM. Of course it isn't quite this simple. Since you have a 12-bit word you will have to figure out how to send both the X and Y coordinates (6 bits each) and the color. You can do this one of two ways: either have two special addresses (one for color, one for location) or a FSM in the VGA module which takes the first write as the location and latches it and then the second one as the color. It's also nice to provide the ability to read from the VGA BRAM, but this isn't essential.

I am assuming you are familiar with memory-mapped I/O from 182, so if this is not clear please come see me soon!