19.

Concluding Remarks

CS227

Spring 2011

Outline

- Summary of Key Ideas
 - Limitations of Symbolic Representations
 - Syllabus for the Final
 - Next Steps
-

Four Clusters of Topics

- Object-oriented representations, description logics, ontologies
 - Logic programming, defaults, negation, answer set programs
 - Constraint satisfaction, abductive reasoning, qualitative reasoning
 - Actions and Planning
-

Object Oriented Representations

- Key Representation Constructs
 - class, individual, slot and facet
 - subclass-of, instance-of
 - domain, range, cardinality, numeric-minimum, etc
 - Key Reasoning Operations
 - Inheritance
 - Default values
-

Structured Descriptions

- Key Representation Constructs
 - Class, individual, role
 - Concept forming constructors (AND, ALL, EXISTS, FILLS...)
 - Role forming constructors (RESTR, ...)
 - Key Reasoning Operations
 - Subsumption
 - Classification
-

Key Questions in KR&R Research

- Why restrict the representation language?
 - Why not represent anything that needs to be represented using whatever representation language is needed?
 - Why not use English as a representation language?
-

Approach to KR&R System Development

- Given a problem identify a combination of representation and reasoning methods that can solve the problem
 - Design a way of combining them into one mechanism
 - Hybrid reasoning
-

Ontologies

- Everyone uses and has an ontology regardless of whether they know it
 - Ontology provides a representation that is somewhere in between an un-interpreted logical representation and the natural language
 - There are some upper level distinctions and design tools available to help guide the process
 - The ontology construction is an engineering process no different than any other software artifact
 - Ontologies should be evaluated just like any other software system
-

Different Flavors of Rule Languages

- Reasoning with Horn Clauses
 - Foundation for logic programming family of languages
 - Procedural control of reasoning
 - Negation as Failure - a practical alternative to classical negation
 - Production Systems
 - Foundation of expert systems / rule-based systems
 - Advanced logics
 - Combining rules with object-oriented and structured representations, higher order logic, modal logic
 - Non Monotonic Reasoning
 - Representing default knowledge, answer set programming
-

Answer Set Programming

- Ability to deal with
 - Disjunction
 - Mixing classical and default negation
 - Formulate many search problems as answer set programs
 - Answer set solvers
-

Expressive Overlaps among KRs

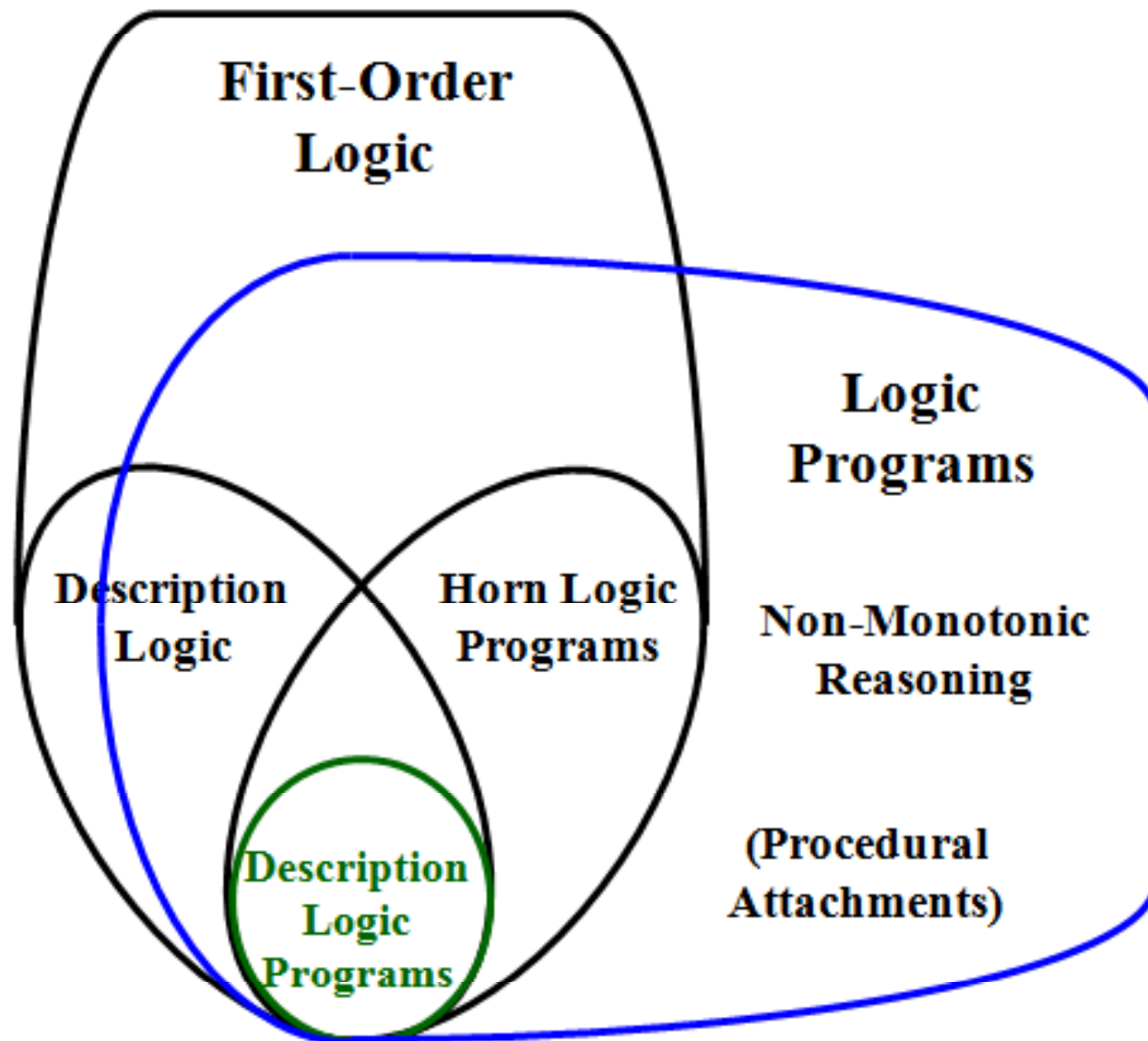

Combining Description Logics and Logic Programs

We considered F-Logic and its implementation Flora
Combining formalisms is an active area of research

Reasoning in the OWL 2 Full Ontology Language using First-Order Automated Theorem Proving

Michael Schneider^{1*} and Geoff Sutcliffe²

¹ FZI Research Center for Information Technology, Germany

² University of Miami, USA

Abstract. OWL 2 has been standardized by the World Wide Web Consortium (W3C) as a family of ontology languages for the Semantic Web. The most expressive of these languages is OWL 2 Full, but to date no reasoner has been implemented for this language. Consistency and entailment checking are known to be undecidable for OWL 2 Full. We have translated a large fragment of the OWL 2 Full semantics into first-order logic, and used automated theorem proving systems to do reasoning based on this theory. The results are promising, and indicate that this approach can be applied in practice for effective OWL reasoning, beyond the capabilities of current Semantic Web reasoners.

Key words: Semantic Web, OWL, First-order logic, ATP

Combining Production Systems and Ontologies

Martin Rezk and Werner Nutt

KRDB Research Centre, Faculty of Computer Science

Free University of Bozen-Bolzano, Italy

{rezk,nutt}@inf.unibz.it

Abstract. Production systems are an established paradigm in knowledge representation, while ontologies are widely used to model and reason about the domain of an application. Description logics, underlying for instance the Web ontology language OWL, are a well-studied formalism to express ontologies. In this work we combine production systems (PS) and Description Logics (DL) in such a way that allows one to express both, facts and rules, using an ontology language. We explore the space of design options for combining the traditional closed world semantics of PS with the open world semantics of DL. We propose a generic semantics, independent of the specific DL, where states are akin to *ABoxes* in DLs and negation is interpreted as fact removal. A rule fires if (i) its conditions are entailed by the current state, (ii) its actions change the current state and (iii) are consistent with it. Thus a rule engine can be created, using technologies for conjunctive query answering and satisfiability tests for DLs. We encode our semantics in a fixpoint extension of first-order logic. We show that in special cases (monotonic and light PS) the encoding reduces to μ -calculus, which makes static analysis tasks such as termination checking decidable.

Specialized Reasoning Methods

- Constraints, qualitative, abductive

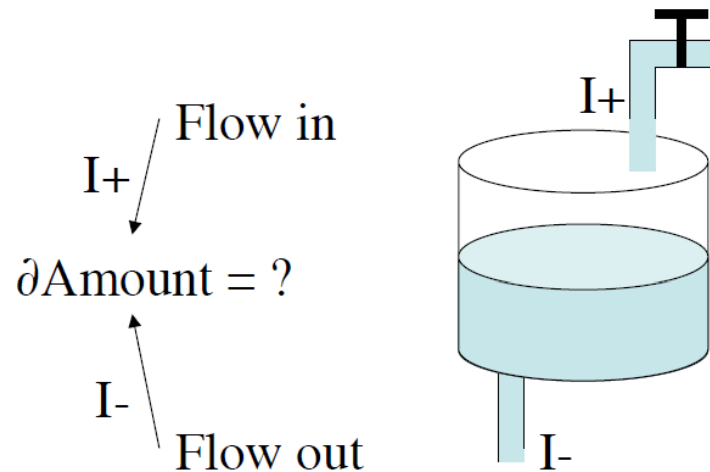
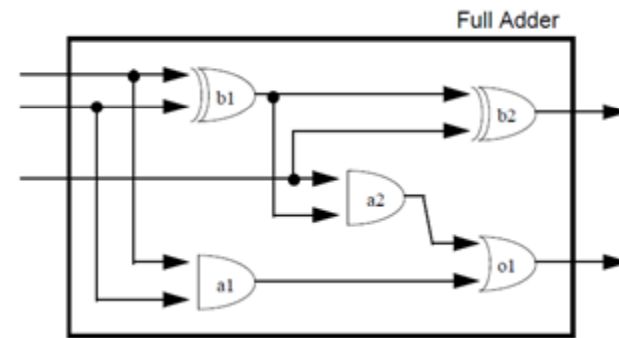

Actions

- Situation calculus as a mechanism to represent change
 - Representation of pre-conditions and effects
 - Successor state axioms
 - Reasoning check legality of a sequence of actions and temporal projection
-

Planning

- Classical planning techniques
 - STRIPS, Graph Plan, Heuristics
- Using knowledge during planning
 - HTN Planning
- CSP, SAT, ASP for planning

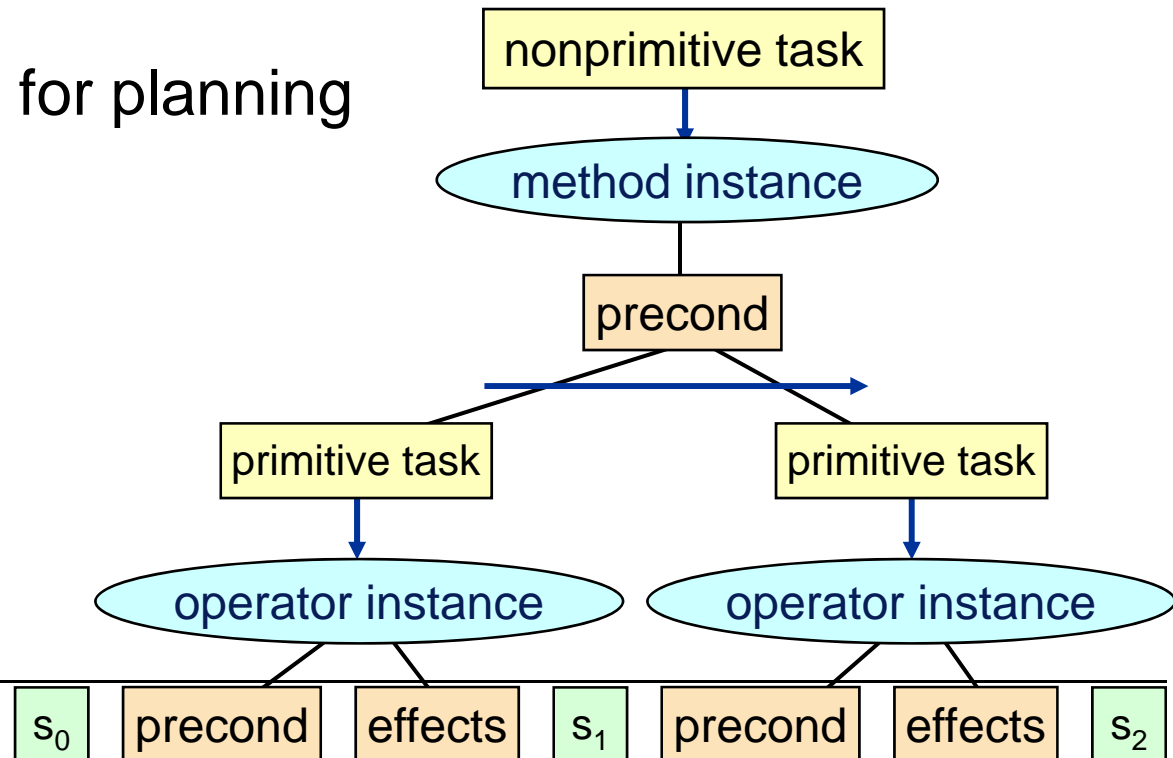

Abstraction, Reformulation, Approximation

- Abstraction, reformulation and approximation concepts are pervasive in
 - Conceptual representation of knowledge
 - Problem solving
 - (Oversimplified) characterization of ARA concepts
 - abstraction- ignoring some details
 - reformulation- changing the ontology
 - Approximation – concepts that defy complete definitions
 - While there is substantial work in using ARA techniques in CSP and planning, little work in knowledge acquisition and explanation generation
-

Applications and Impact Areas



Computer reading books



Learn to repair a robot on Mars



ENCYCLOPEDIA
On Demand



Military
Logistics



Game
Playing

Practical Skills

- Ontology languages and tools
 - Protégé, OWL
 - Exposure to Semantic Web, RDF
 - Rule languages and tools
 - FLORA
 - Planning languages and tools
 - PDDL, FF
 - (Optionally) Constraint reasoning tools
 - Gecode
-

Outline

- Summary of Key Ideas
 - **Limitations of Symbolic Representations**
 - Syllabus for the Final
 - Next Steps
-

Logic as the Foundation of KR&R

- In this course, we used logic as the foundation for representing knowledge
- There are, however, criticisms of this approach:
 - Deductive reasoning is not enough
 - Deductive reasoning is too expensive
 - Writing down all the knowledge is infeasible
 - Other approaches do it better and cheaper

Addressing Criticism of Logic

- Deductive reasoning is not enough
 - Non-monotonic reasoning and defaults
 - Inductive logic programming (See <http://ilp2010.dsi.unifi.it/>)
 - Abductive reasoning
 - Deductive reasoning is too expensive
 - Tractable subsets of logic
 - Progress on SAT solver techniques
 - Writing down all the knowledge is not feasible
 - Focusing on explicitly written down knowledge
 - Other approaches do it better and cheaper
 - Find ways to combine logic with other methods
-

Probabilistic Representations

- Probabilistic representations were omitted from this course by design, but are covered in-depth in:
 - CS228: Probabilistic Graphical Models
-

Outline

- Summary of Key Ideas
 - Limitations of Symbolic Representations
 - Syllabus for the Final
 - Next Steps
-

Syllabus for the Final

- Lecture 11 onwards
 - Answer set programming, Abductive reasoning, constraint satisfaction, representation and reasoning with actions, STRIPS Planning, HTN Planning, CSP for planning, abstraction, reformulation, approximation
-

Outline

- Summary of Key Ideas
 - Limitations of Symbolic Representations
 - Syllabus for the Final
 - **Next Steps**
-

Next Steps

- This course can be followed by
 - CS223: Rational Agency and Intelligent Interaction
 - CS224: Multi-agent systems
 - CS227B: General Game Playing
 - Application of techniques in your respective projects
 - Research opportunities in symbolic representation and reasoning
 - Research / Internship opportunities
-

Emphasis on Content

- “Writing knowledge base content should be front right and center in a KR &R course
 - If I were to have a life threatening event, I will like to be rushed to medical department because they have knowledge, and not to the math department because they have Field medal worthy reasoners”
 - Ed Feigenbaum
-