

Instantaneous Kinematics

Differential Motion

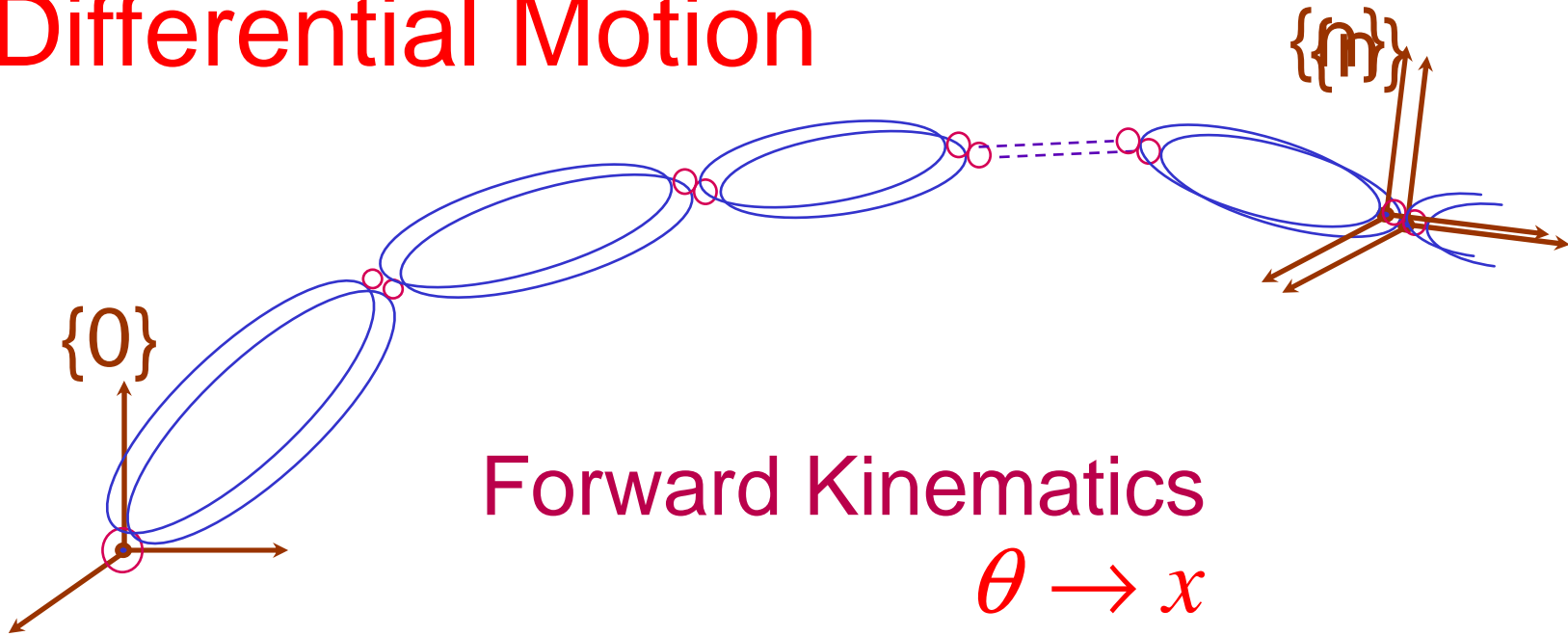

Forward Kinematics

$$\theta \rightarrow x$$

Instantaneous Kinematics

$$\theta + \delta\theta \rightarrow x + \delta x$$

Relationship: $\delta\theta \leftrightarrow \delta x$

$$\dot{\theta} \leftrightarrow \dot{x}$$

Linear Velocity

Angular Velocity

J a c o b i a n

- Differential Motion
- Linear & Angular Motion
- Velocity Propagation
- Explicit Form
- Static Forces

Joint Coordinates

$$\text{coordinate } -i : \begin{cases} \theta_i & \text{revolute} \\ d_i & \text{prismatic} \end{cases}$$

Joint coordinate-i:

$$q_i = \bar{\varepsilon}_i \theta_i + \varepsilon_i d_i$$

with $\varepsilon_i = \begin{cases} 0 & \text{revolute} \\ 1 & \text{prismatic} \end{cases}$

and $\bar{\varepsilon}_i = 1 - \varepsilon_i$

Joint Coordinate Vector:

$$q = (q_1 q_2 \dots q_n)^T$$

Jacobians: Direct Differentiation

$$x = f(q); \quad \begin{pmatrix} x_1 \\ x_2 \\ \vdots \\ x_m \end{pmatrix} = \begin{pmatrix} f_1(q) \\ f_2(q) \\ \vdots \\ f_m(q) \end{pmatrix}$$

$$\begin{aligned} \delta x_1 &= \frac{\partial f_1}{\partial q_1} \delta q_1 + \dots + \frac{\partial f_1}{\partial q_n} \delta q_n \\ \vdots & \\ \delta x_m &= \frac{\partial f_m}{\partial q_1} \delta q_1 + \dots + \frac{\partial f_m}{\partial q_n} \delta q_n \end{aligned} \quad \delta x = \begin{bmatrix} \frac{\partial f_1}{\partial q_1} & \dots & \frac{\partial f_1}{\partial q_n} \\ \vdots & \vdots & \vdots \\ \frac{\partial f_m}{\partial q_1} & \dots & \frac{\partial f_m}{\partial q_n} \end{bmatrix} \cdot \delta q$$

$$\delta x_{(m \times 1)} = J_{(m \times n)}(q) \delta q_{(n \times 1)}$$

Jacobian

$$\delta x_{(m \times 1)} = J_{(m \times n)}(q) \delta q_{(n \times 1)}$$

$$\dot{x}_{(m \times 1)} = J_{(m \times n)}(q) \dot{q}_{(n \times 1)}$$

where

$$J_{ij}(q) = \frac{\partial}{\partial q_j} f_i(q)$$

Example

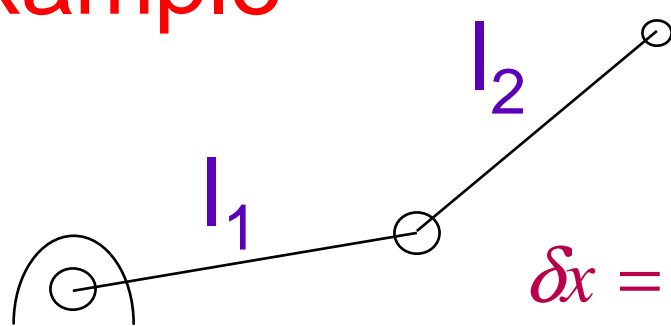

$$(x, y) \quad x = l_1 c_1 + l_2 c_{12}$$

$$y = l_1 s_1 + l_2 s_{12}$$

$$\delta x = -(l_1 s_1 + l_2 s_{12}) \delta \theta_1 - l_2 s_{12} \delta \theta_2$$

$$\delta y = (l_1 c_1 + l_2 c_{12}) \delta \theta_1 + l_2 c_{12} \delta \theta_2$$

$$\delta X = \begin{bmatrix} \delta x \\ \delta y \end{bmatrix} = \begin{bmatrix} -y & -l_2 s_{12} \\ x & l_2 c_{12} \end{bmatrix} \begin{pmatrix} \delta \theta_1 \\ \delta \theta_2 \end{pmatrix}$$

$$\delta x = J(\theta) \delta \theta$$

$$\dot{x} = J(\theta) \dot{\theta}$$

$$J \equiv \begin{pmatrix} \frac{\partial x}{\partial \theta_1} & \frac{\partial x}{\partial \theta_2} \\ \frac{\partial y}{\partial \theta_1} & \frac{\partial y}{\partial \theta_2} \end{pmatrix} = \begin{bmatrix} -y & -l_2 s_{12} \\ x & l_2 c_{12} \end{bmatrix}$$

Stanford Scheinman Arm

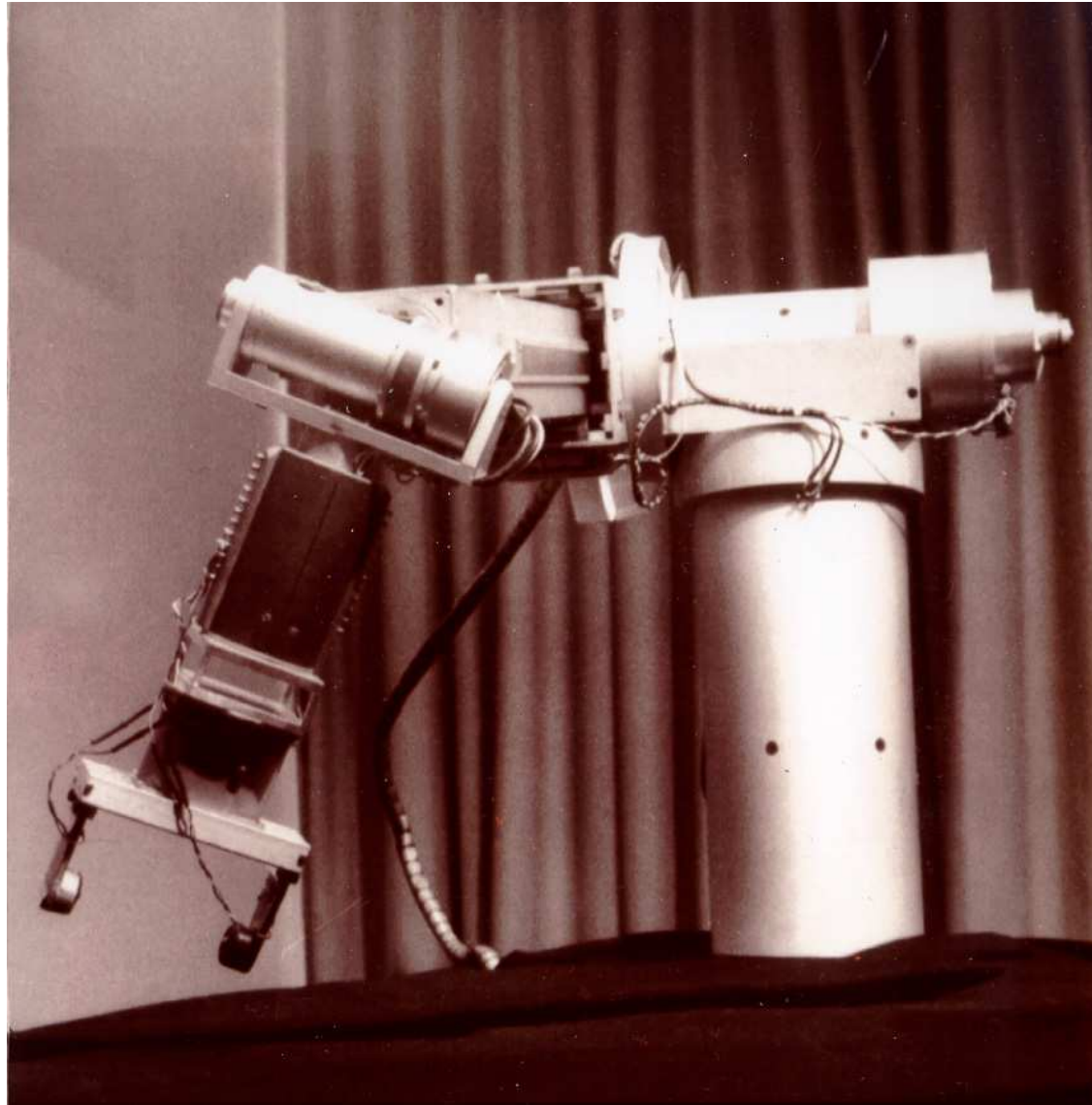

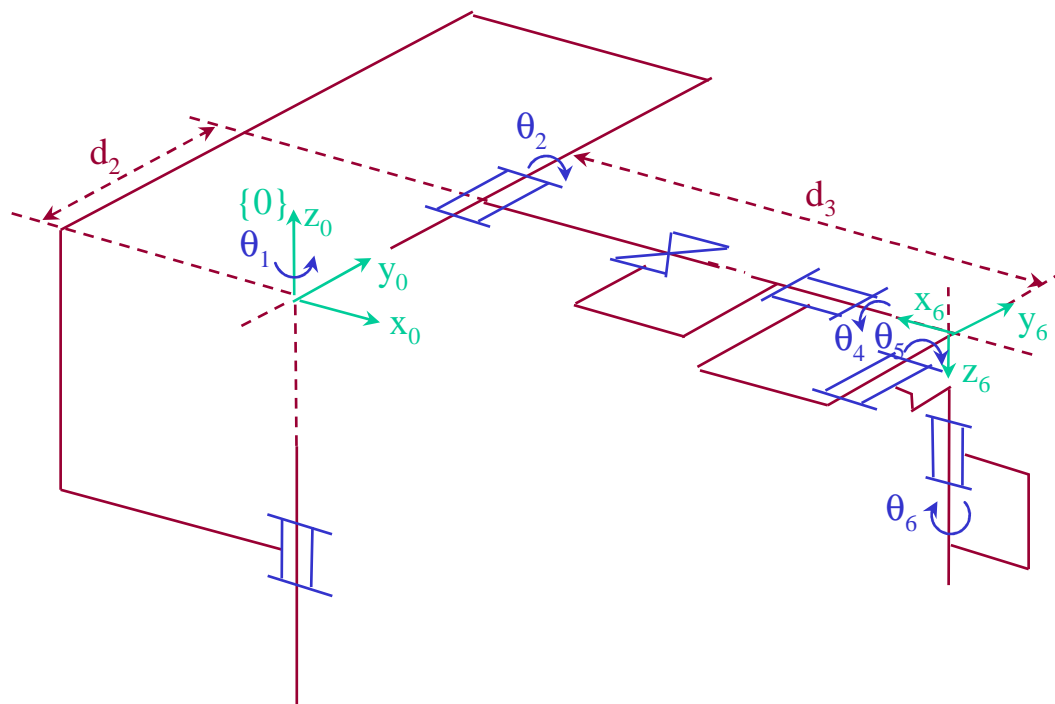

i	α_{i-1}	a_{i-1}	d_i	θ_i
1	0	0	0	θ_1
2	-90	0	d_2	θ_2
3	90	0	d_3	0
4	0	0	0	θ_4
5	-90	0	0	θ_5
6	90	0	0	θ_6

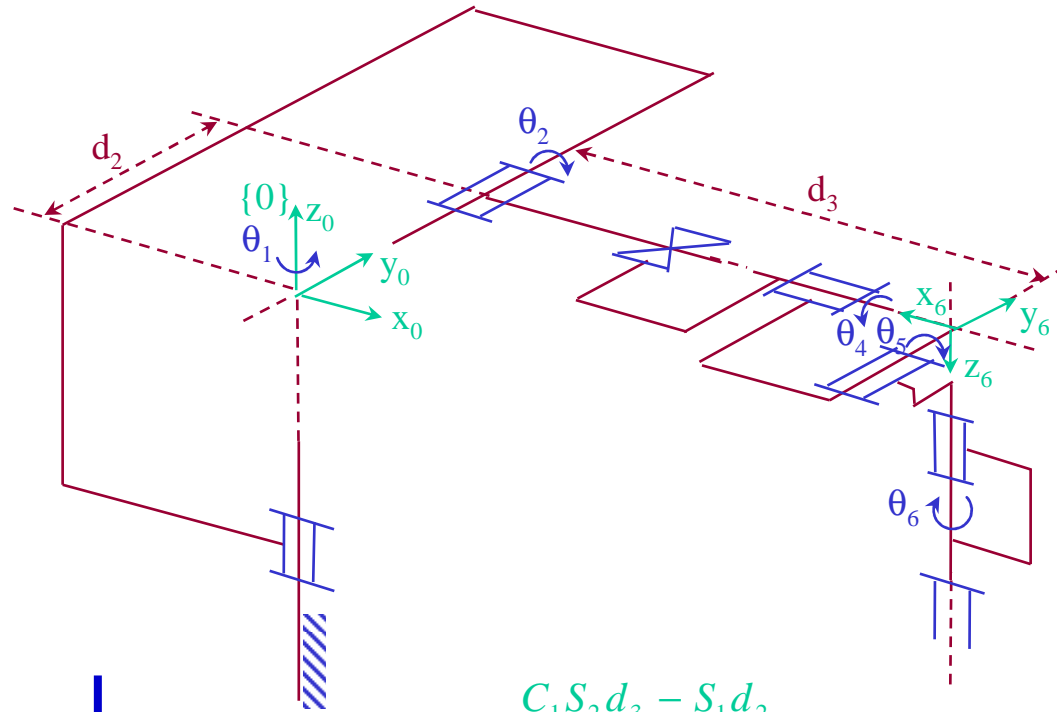

$$x = \begin{pmatrix} x_P \\ r_1 \\ r_2 \\ r_3 \end{pmatrix} =$$

$$\begin{aligned} &C_1 S_2 d_3 - S_1 d_2 \\ &S_1 S_2 d_3 + C_1 d_2 \\ &C_2 d_3 \end{aligned}$$

$$\begin{aligned} &C_1 [C_2 (C_4 C_5 C_6 - S_4 S_6) - S_2 S_5 C_6] - S_1 (S_4 C_5 C_6 + C_4 S_6) \\ &S_1 [C_2 (C_4 C_5 C_6 - S_4 S_6) - S_2 S_5 C_6] + C_1 (S_4 C_5 C_6 + C_4 S_6) \\ &\quad - S_2 (C_4 C_5 C_6 - S_4 S_6) - C_2 S_5 C_6 \\ &C_1 [-C_2 (C_4 C_5 S_6 + S_4 C_6) + S_2 S_5 S_6] - S_1 (-S_4 C_5 S_6 + C_4 C_6) \\ &S_1 [-C_2 (C_4 C_5 S_6 + S_4 C_6) + S_2 S_5 S_6] + C_1 (-S_4 C_5 S_6 + C_4 C_6) \\ &\quad S_2 (C_4 C_5 S_6 + S_4 C_6) + C_2 S_5 S_6 \\ &C_1 (C_2 C_4 S_5 + S_2 C_5) - S_1 S_4 S_5 \\ &S_1 (C_2 C_4 S_5 + S_2 C_5) + C_1 S_4 S_5 \\ &\quad - S_2 C_4 S_5 + C_2 C_5 \end{aligned}$$

Stanford Scheinman Arm

Position

$$x_p = \begin{bmatrix} c_1 s_2 d_3 - s_1 d_2 \\ s_1 s_2 d_3 + c_1 d_2 \\ c_2 d_3 \end{bmatrix}$$

$$\dot{x}_p = \begin{pmatrix} \dot{x} \\ \dot{y} \\ \dot{z} \end{pmatrix} = \begin{bmatrix} \phantom{\dot{x}} & \phantom{\dot{y}} & \phantom{\dot{z}} & \phantom{\dot{x}} & \phantom{\dot{y}} & \phantom{\dot{z}} \\ \phantom{\dot{x}} & \phantom{\dot{y}} & \phantom{\dot{z}} & \phantom{\dot{x}} & \phantom{\dot{y}} & \phantom{\dot{z}} \\ \phantom{\dot{x}} & \phantom{\dot{y}} & \phantom{\dot{z}} & \phantom{\dot{x}} & \phantom{\dot{y}} & \phantom{\dot{z}} \end{bmatrix} \begin{bmatrix} \dot{q}_1 \\ \dot{q}_2 \\ \dot{q}_3 \\ \dot{q}_4 \\ \dot{q}_5 \\ \dot{q}_6 \end{bmatrix}$$

$$\dot{x}_{p(3 \times 1)} = J_{x_p(3 \times 6)}(q) \dot{q}_{(6 \times 1)}$$

Linear Velocity **V**

Orientation: Direction Cosines

$$\dot{x}_R = J_{X_R}(q)\dot{q} \quad x_R = \begin{bmatrix} r_1(q) \\ r_2(q) \\ r_3(q) \end{bmatrix}$$

$$\dot{x}_R = \begin{pmatrix} \dot{r}_1 \\ \dot{r}_2 \\ \dot{r}_3 \end{pmatrix}_{(9 \times 1)} = \begin{pmatrix} \frac{\partial r_1}{\partial q_1} & \dots & \frac{\partial r_1}{\partial q_6} \\ \frac{\partial r_2}{\partial q_1} & \dots & \frac{\partial r_2}{\partial q_6} \\ \frac{\partial r_3}{\partial q_1} & \dots & \frac{\partial r_3}{\partial q_6} \\ \frac{\partial r_1}{\partial q_1} & \dots & \frac{\partial r_1}{\partial q_6} \end{pmatrix}_{(9 \times 6)} \begin{pmatrix} \dot{q}_1 \\ \dot{q}_2 \\ \vdots \\ \dot{q}_6 \end{pmatrix}_{(6 \times 1)}$$

$$\mathbf{x}_R = \begin{pmatrix} C_1[C_2(C_4C_5C_6 - S_4S_6) - S_2S_5C_6] - S_1(S_4C_5C_6 + C_4S_6) \\ S_1[C_2(C_4C_5C_6 - S_4S_6) - S_2S_5C_6] + C_1(S_4C_5C_6 + C_4S_6) \\ -S_2(C_4C_5C_6 - S_4S_6) - C_2S_5C_6 \\ C_1[-C_2(C_4C_5S_6 + S_4C_6) + S_2S_5S_6] - S_1(-S_4C_5S_6 + C_4C_6) \\ S_1[-C_2(C_4C_5S_6 + S_4C_6) + S_2S_5S_6] + C_1(-S_4C_5S_6 + C_4C_6) \\ S_2(C_4C_5S_6 + S_4C_6) + C_2S_5S_6 \\ C_1(C_2C_4S_5 + S_2C_5) - S_1S_4S_5 \\ S_1(C_2C_4S_5 + S_2C_5) + C_1S_4S_5 \\ -S_2C_4S_5 + C_2C_5 \end{pmatrix}$$

$$\dot{\mathbf{x}}_R = \begin{pmatrix} \dot{r}_1 \\ \dot{r}_2 \\ \dot{r}_3 \end{pmatrix}_{(9 \times 1)} = \begin{pmatrix} \frac{\partial r_1}{\partial q_1} & \dots & \frac{\partial r_1}{\partial q_6} \\ \frac{\partial r_2}{\partial q_1} & \dots & \frac{\partial r_2}{\partial q_6} \\ \frac{\partial r_3}{\partial q_1} & \dots & \frac{\partial r_3}{\partial q_6} \\ \frac{\partial q_1}{\partial q_1} & \dots & \frac{\partial q_1}{\partial q_6} \\ \frac{\partial q_2}{\partial q_1} & \dots & \frac{\partial q_2}{\partial q_6} \\ \vdots \\ \frac{\partial q_6}{\partial q_1} & \dots & \frac{\partial q_6}{\partial q_6} \end{pmatrix}_{(9 \times 6)} \begin{pmatrix} \dot{q}_1 \\ \dot{q}_2 \\ \vdots \\ \dot{q}_6 \end{pmatrix}_{(6 \times 1)}$$

Representations

$$X = \begin{bmatrix} x_P \\ x_R \end{bmatrix}$$

- Cartesian
- Spherical
- Cylindrical
-
- Euler Angles
- Direction Cosines
- Euler Parameters

Jacobian for X

$$\begin{aligned}\dot{x}_P &= J_{X_P}(q)\dot{q} \\ \dot{x}_R &= J_{X_R}(q)\dot{q}\end{aligned}\quad \begin{pmatrix} \dot{x}_P \\ \dot{x}_R \end{pmatrix} = \begin{pmatrix} J_{X_P}(q) \\ J_{X_R}(q) \end{pmatrix} \dot{q}$$

Cartesian & Direction Cosines

$$\dot{X}_{(12 \times 1)} = J_X(q)_{(12 \times 6)} \dot{q}_{(6 \times 1)}$$

The Jacobian is dependent on the representation

Basic Jacobian

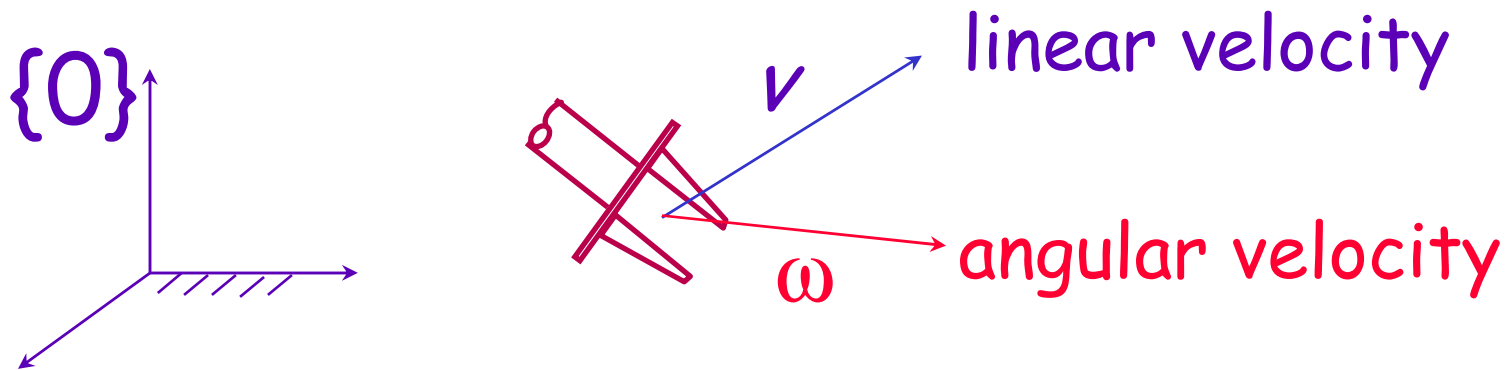

$$\begin{pmatrix} v \\ \omega \end{pmatrix}_{(6 \times 1)} = J_0(q)_{(6 \times n)} \dot{q}_{(n \times 1)}$$

$$\dot{x}_P = E_P(x_P)v$$

$$\dot{x}_R = E_R(x_R)\omega$$

Examples

$$* \quad x_R = \begin{pmatrix} \alpha \\ \beta \\ \gamma \end{pmatrix}; E_R(x_R) = \begin{pmatrix} -\frac{s\alpha \cdot c\beta}{s\beta} & \frac{c\alpha \cdot c\beta}{s\beta} & 1 \\ c\alpha & s\alpha & 0 \\ \frac{s\alpha}{s\beta} & -\frac{c\alpha}{s\beta} & 0 \end{pmatrix}$$

$$* \quad x_P = \begin{pmatrix} x \\ y \\ z \end{pmatrix}; E_P(x_P) = \begin{pmatrix} 1 & 0 & 0 \\ 0 & 1 & 0 \\ 0 & 0 & 1 \end{pmatrix}$$

Jacobian for X

Given a representation $x = \begin{bmatrix} x_P \\ x_R \end{bmatrix}$

$$\dot{x} = J_x(q) \dot{q}$$

$$J_x(q) = E(x) J_0(q)$$

Basic Jacobian $\begin{pmatrix} v \\ w \end{pmatrix} = J_0(q) \dot{q}$

Jacobian and Basic Jacobian

$$\begin{pmatrix} v \\ \omega \end{pmatrix} = J_0(q) \dot{q}$$

$$\begin{pmatrix} v \\ \omega \end{pmatrix} = \begin{pmatrix} J_v \\ J_\omega \end{pmatrix} \dot{q}$$

$$\begin{cases} v = J_v \dot{q} \\ \omega = J_\omega \dot{q} \end{cases}$$

$$\dot{x}_P = E_P \cdot v \Rightarrow \dot{x}_P = (E_P \cdot J_v) \dot{q}$$

$$\dot{x}_R = E_R \cdot \omega \Rightarrow \dot{x}_R = (E_R \cdot J_\omega) \dot{q}$$

$$\begin{cases} J_{X_P} = E_P \cdot J_v \\ J_{X_R} = E_R \cdot J_\omega \end{cases}$$

$$J = \begin{pmatrix} J_{XP} \\ J_{XR} \end{pmatrix} = \left(\begin{array}{c|c} E_P & 0 \\ \hline 0 & E_R \end{array} \right) \begin{pmatrix} J_v \\ J_w \end{pmatrix}$$



$$J(q) = E(X) J_0(q)$$

$$\begin{pmatrix} v \\ w \end{pmatrix} = J_0(q) \dot{q}$$

With Cartesian Coordinates

$$E_P = I_3 ; J_{XP} = J_v ; \text{ and } E = \left(\begin{array}{c|c} I & 0 \\ \hline 0 & E_R \end{array} \right)$$

Position Representations

Cartesian Coordinates (x, y, z)

$$E_P(X) = I_3$$

Cylindrical Coordinates (ρ, θ, z)

Using $(x \ y \ z)^T = (\rho \cos \theta \ \rho \sin \theta \ z)^T$

$$E_P(X) = \begin{pmatrix} \cos \theta & \sin \theta & 0 \\ -\sin \theta / \rho & \cos \theta / \rho & 0 \\ 0 & 0 & 1 \end{pmatrix}$$

Spherical Coordinates (ρ, θ, ϕ)

Using

$$(x \ y \ z)^T = (\rho \cos \theta \sin \phi \quad \rho \sin \theta \sin \phi \quad \rho \cos \theta)^T$$

$$E_P(X) = \begin{pmatrix} \cos \theta \sin \phi & \sin \theta \sin \phi & \cos \phi \\ -\sin \theta / (\rho \sin \phi) & \cos \theta / (\rho \sin \phi) & 0 \\ \cos \theta \cos \phi / \rho & \sin \theta \cos \phi / \rho & -\sin \phi / \rho \end{pmatrix}$$

Euler Angles

$$x_R = \begin{pmatrix} \alpha \\ \beta \\ \gamma \end{pmatrix}; E_R(x_R) = \begin{pmatrix} -\frac{s\alpha.c\beta}{s\beta} & \frac{c\alpha.c\beta}{s\beta} & 1 \\ c\alpha & s\alpha & 0 \\ \frac{s\alpha}{s\beta} & -\frac{c\alpha}{s\beta} & 0 \end{pmatrix}$$

Singularity of the representation
for $\beta = k\pi$

Jacobian for X

Given a representation $x = \begin{bmatrix} x_P \\ x_R \end{bmatrix}$

$$\dot{x} = J_x(q) \dot{q}$$

$$J_x(q) = E(x) J_0(q)$$

Basic Jacobian $\begin{pmatrix} v \\ w \end{pmatrix} = J_0(q) \dot{q}$

Jacobian

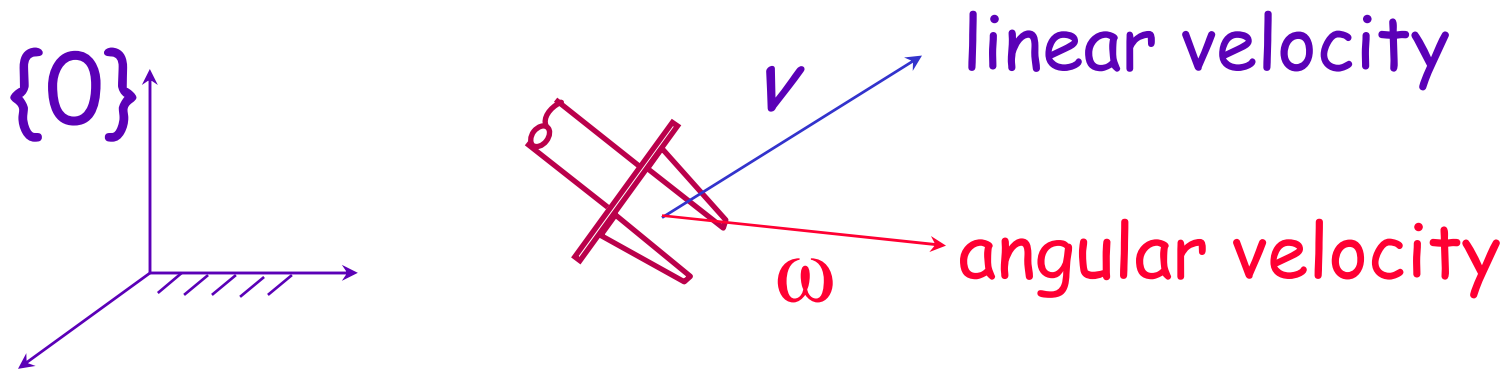

$$\begin{pmatrix} v \\ \omega \end{pmatrix}_{(6 \times 1)} = J(q)_{(6 \times n)} \dot{q}_{(n \times 1)}$$

Linear & Angular Velocities

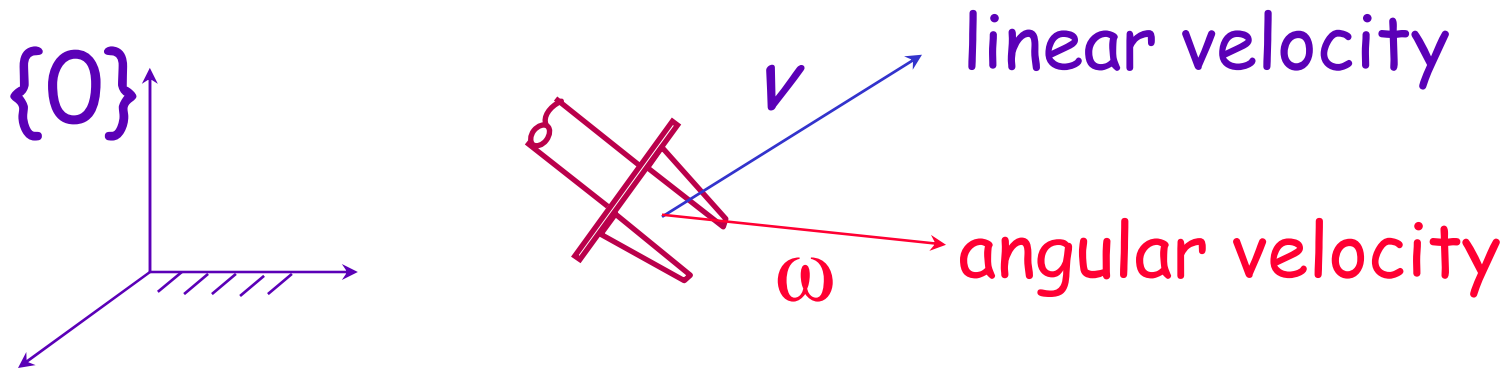

Linear Velocity

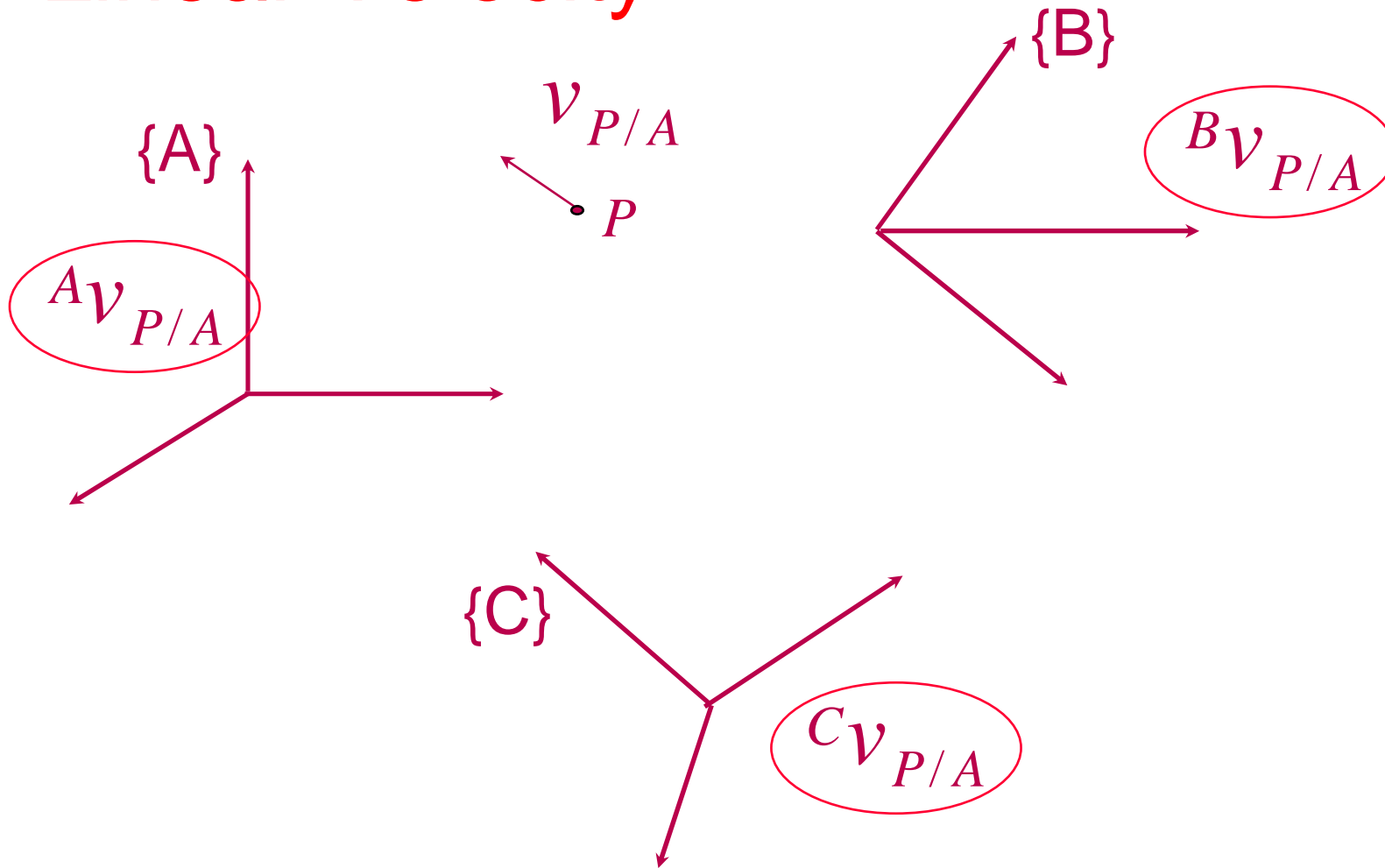

Pure Translation

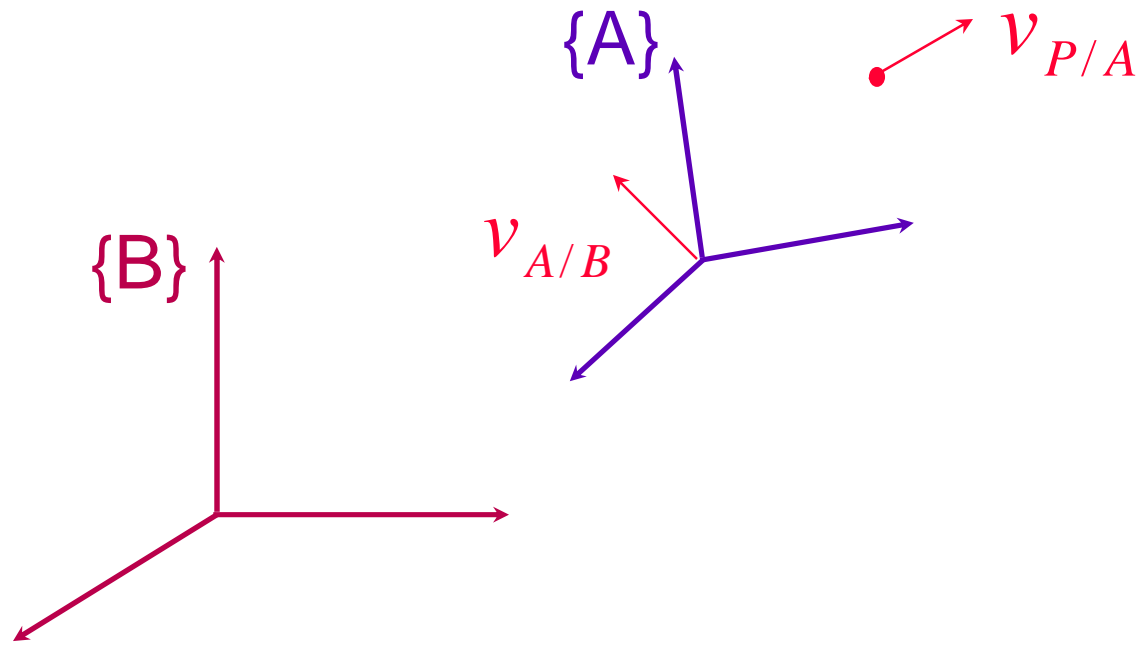

Pure Translation

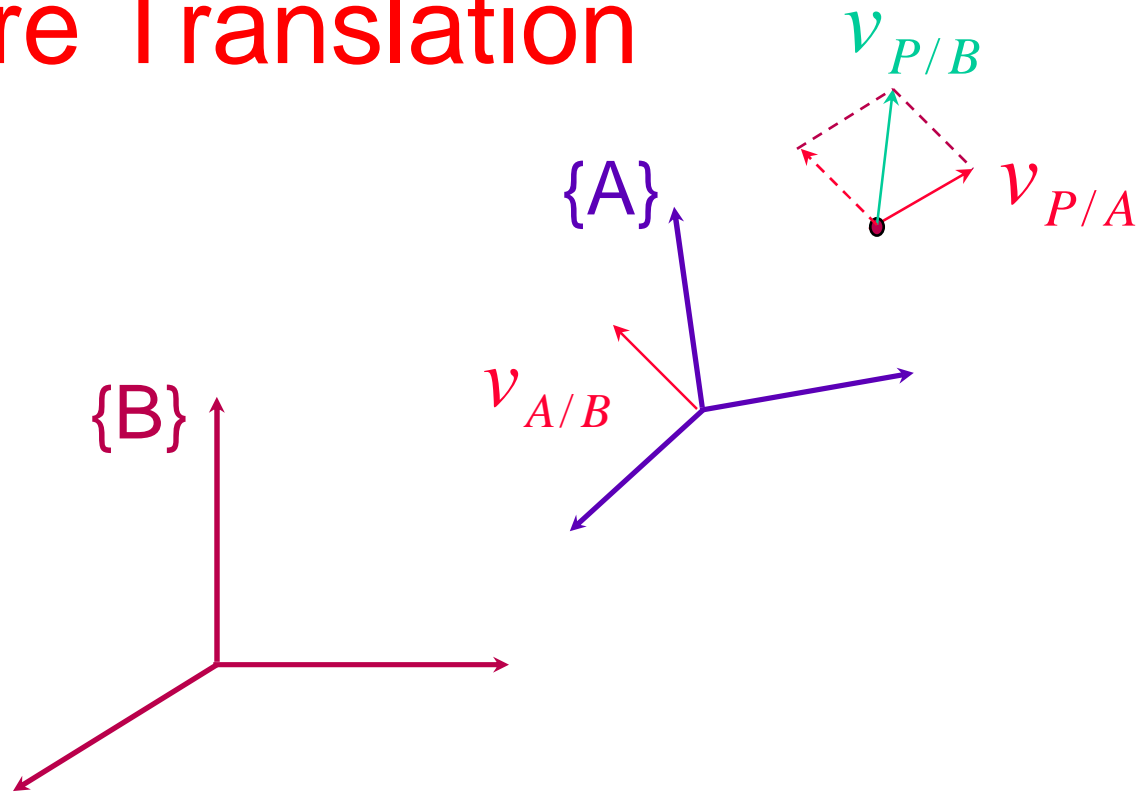

$$v_{P/B} = v_{A/B} + v_{P/A}$$

Rotational Motion

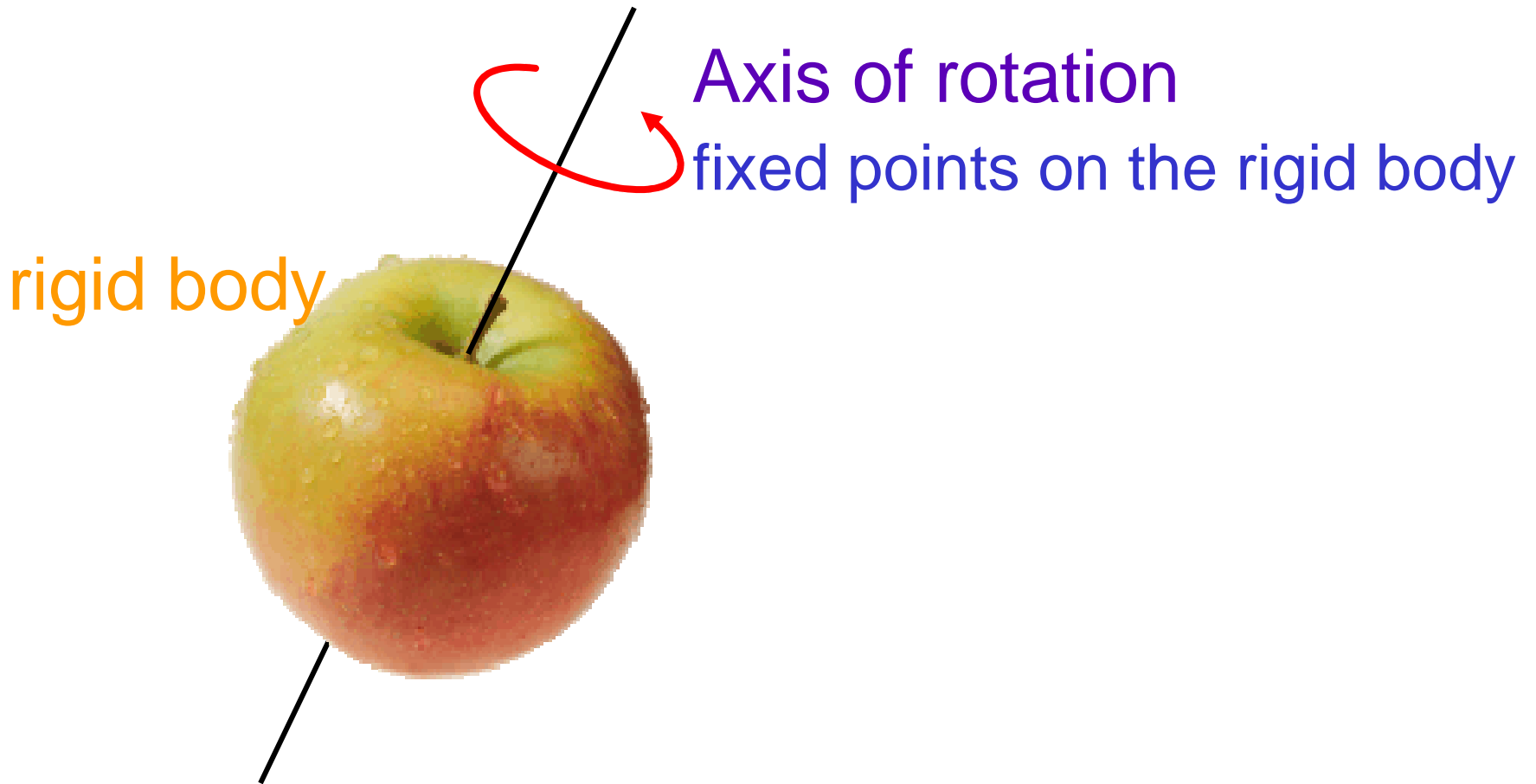

Rotational Motion

Ω Angular Velocity

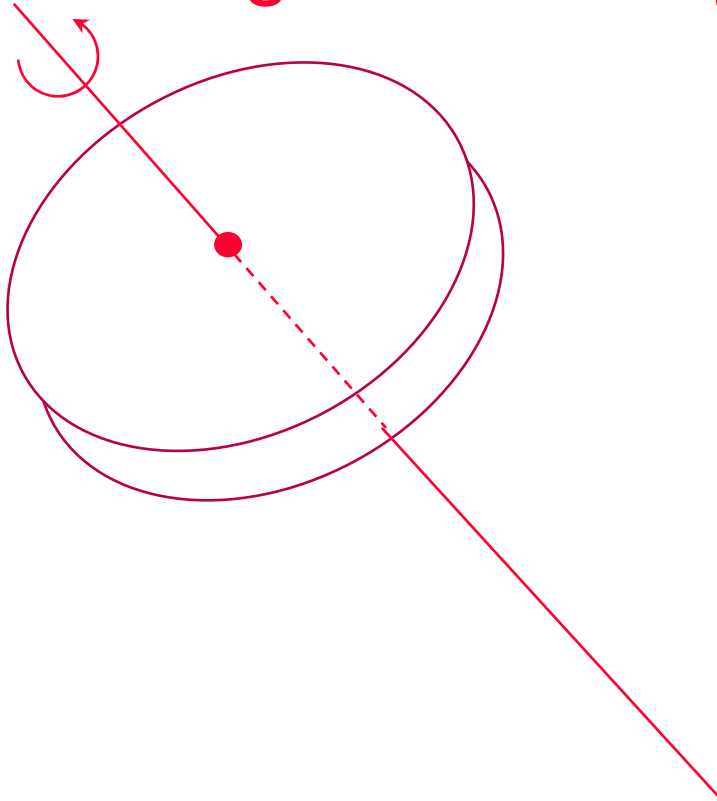

Rotational Motion

Ω Angular Velocity

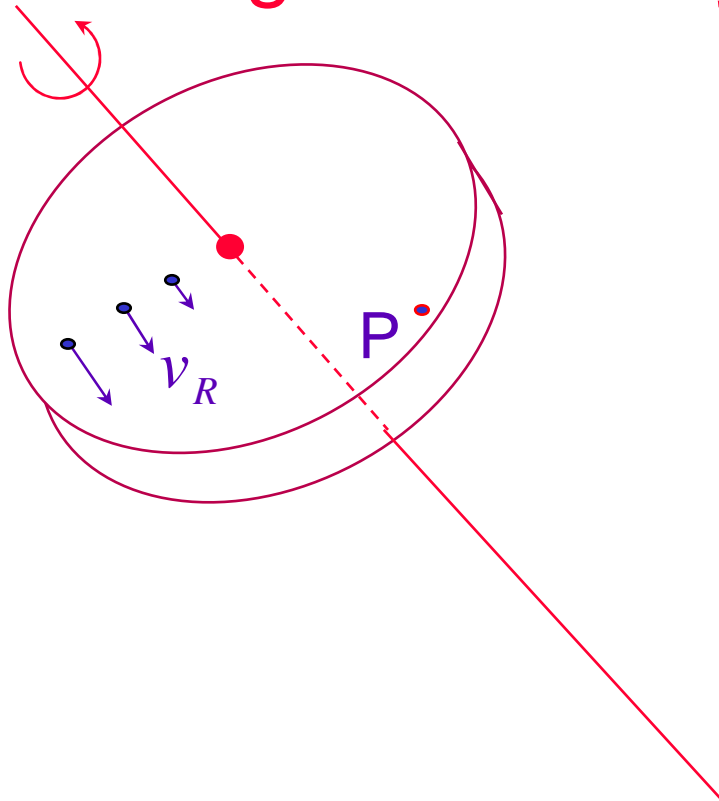

Rotational Motion

Ω Angular Velocity

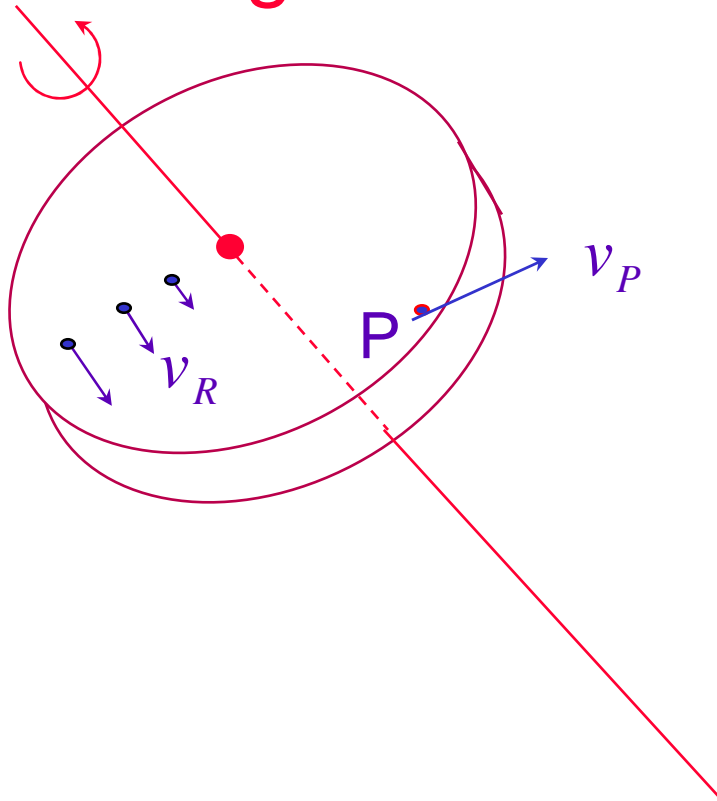

$$v_P = ?$$

Rotational Motion

Ω Angular Velocity

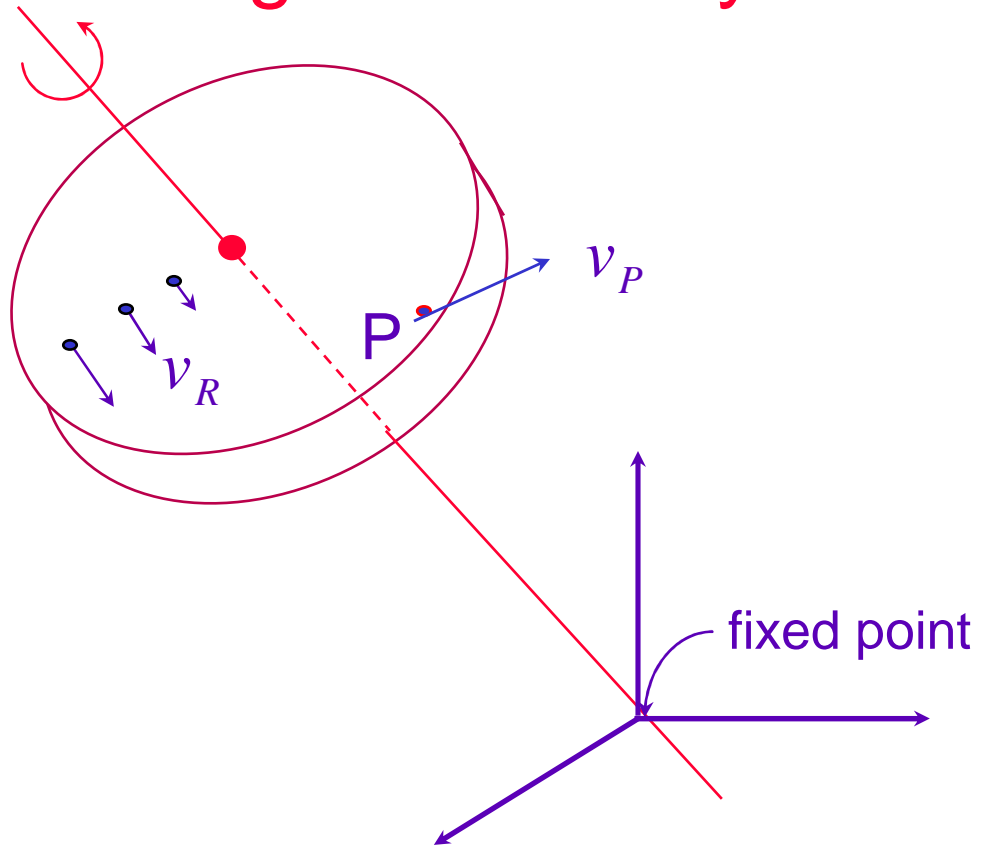

Rotational Motion

Ω Angular Velocity

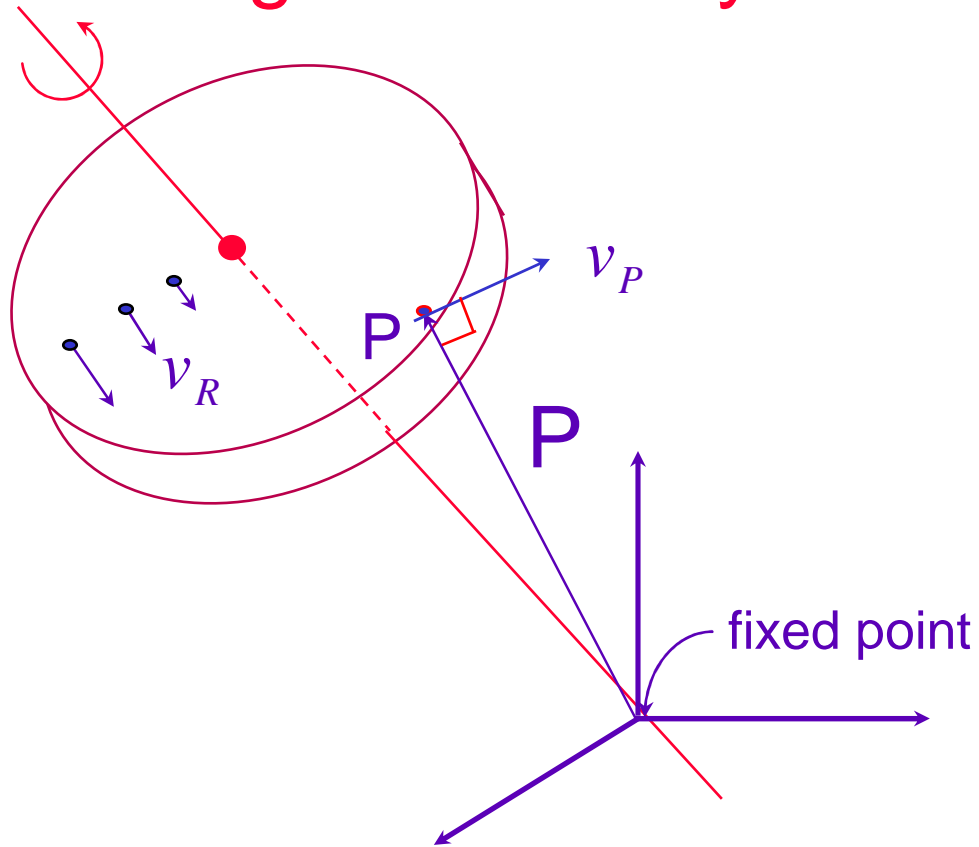

Rotational Motion

Ω Angular Velocity

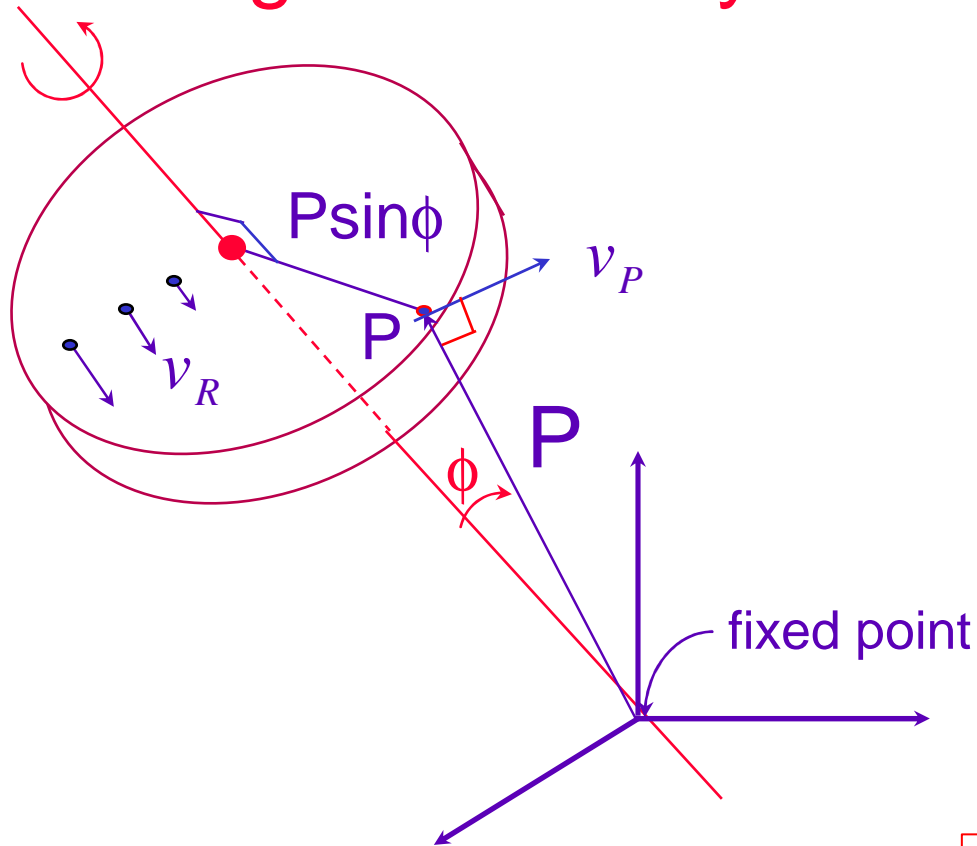

v_P is proportional to:

- $\|\Omega\|$
- $\|P \sin \phi\|$

and

- $v_P \perp \Omega$
- $v_P \perp P$

$$v_P = \Omega \times P$$

Cross Product Operator

$$a = \begin{bmatrix} a_x \\ a_y \\ a_z \end{bmatrix}, b = \begin{bmatrix} b_x \\ b_y \\ b_z \end{bmatrix}$$

$$c = a \times b \Rightarrow c = \hat{a}b$$

vectors \Rightarrow matrices

$a \times \Rightarrow \hat{a}$: a skew-symmetric matrix

$$c = \hat{a}b = \begin{bmatrix} 0 & -a_z & a_y \\ a_z & 0 & -a_x \\ -a_y & a_x & 0 \end{bmatrix} \begin{bmatrix} b_x \\ b_y \\ b_z \end{bmatrix}$$

$$c = \hat{a}b$$

Cross Product Operator

$$v_P = \Omega \times P \Rightarrow v_P = \hat{\Omega}P$$

$\Omega \times \Rightarrow \hat{\Omega}$: a skew-symmetric matrix

$$\Omega = \begin{bmatrix} \Omega_x \\ \Omega_y \\ \Omega_z \end{bmatrix}; P = \begin{bmatrix} P_x \\ P_y \\ P_z \end{bmatrix}$$

$$v_P = \hat{\Omega}P = \begin{bmatrix} 0 & -\Omega_z & \Omega_y \\ \Omega_z & 0 & -\Omega_x \\ -\Omega_y & \Omega_x & 0 \end{bmatrix} \cdot \begin{bmatrix} P_x \\ P_y \\ P_z \end{bmatrix}$$

$$v_P = \hat{\Omega}P$$

Simultaneous linear and angular motion

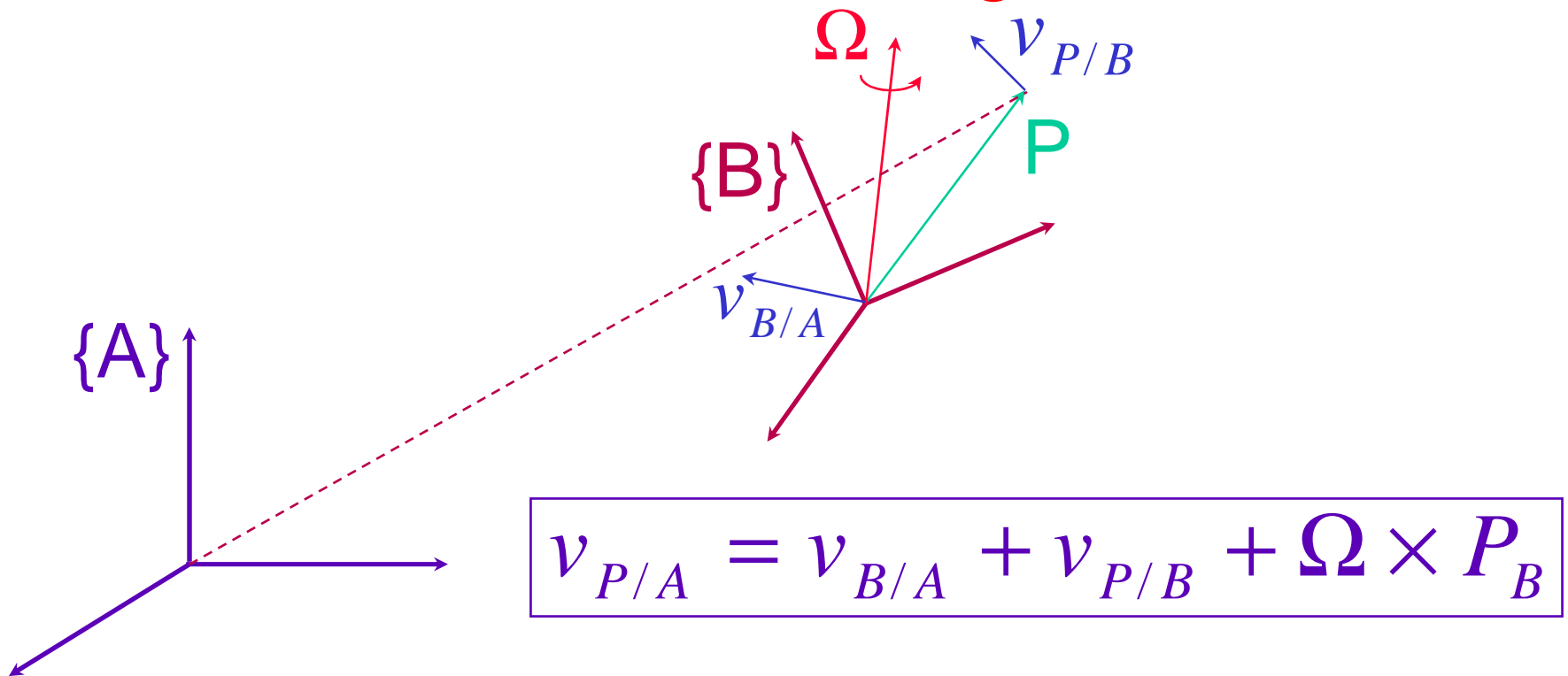

$$v_{P/A} = v_{B/A} + v_{P/B} + \Omega \times P_B$$

$${}^{\textcircled{A}}v_{P/A} = {}^{\textcircled{A}}v_{B/A} + {}^{\textcircled{A}}R^B v_{P/B} + {}^{\textcircled{A}}\Omega_B \times {}^{\textcircled{A}}R^B P_B$$

Spatial Mechanisms

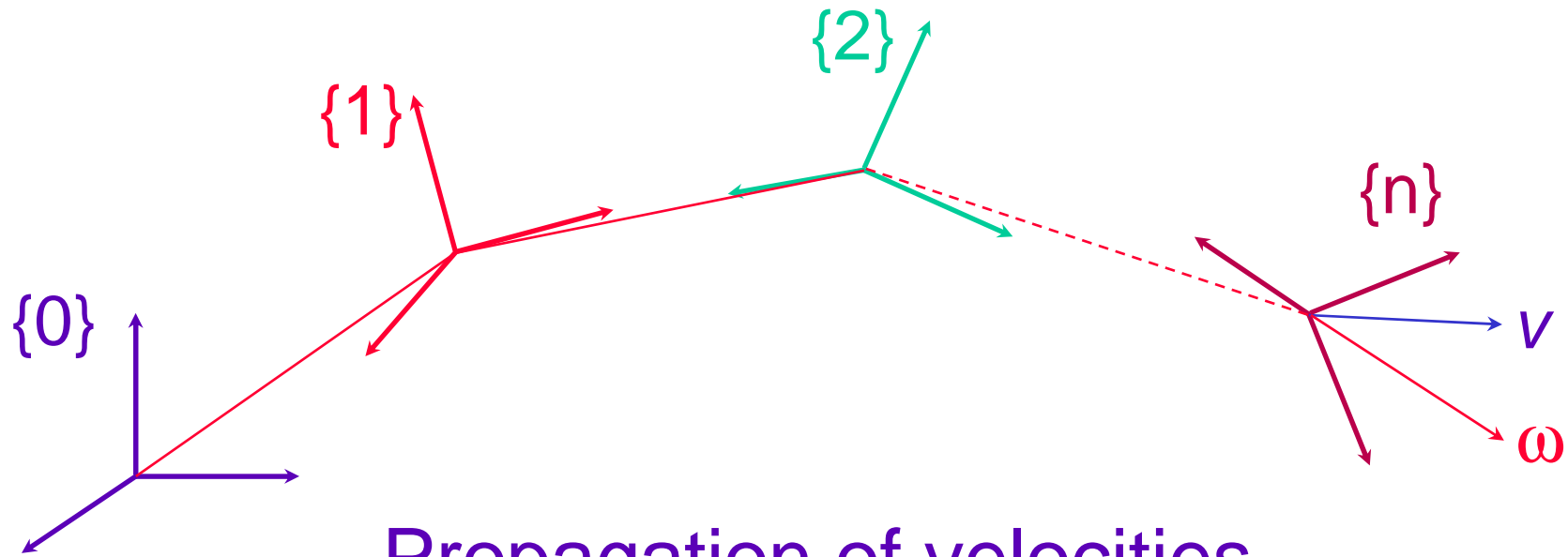

Propagation of velocities

\dot{x} $\begin{cases} v : \text{linear velocity} \\ \omega : \text{angular velocity} \end{cases}$

$$\dot{x} = J(\theta) \cdot \dot{\theta}$$

Velocity propagation

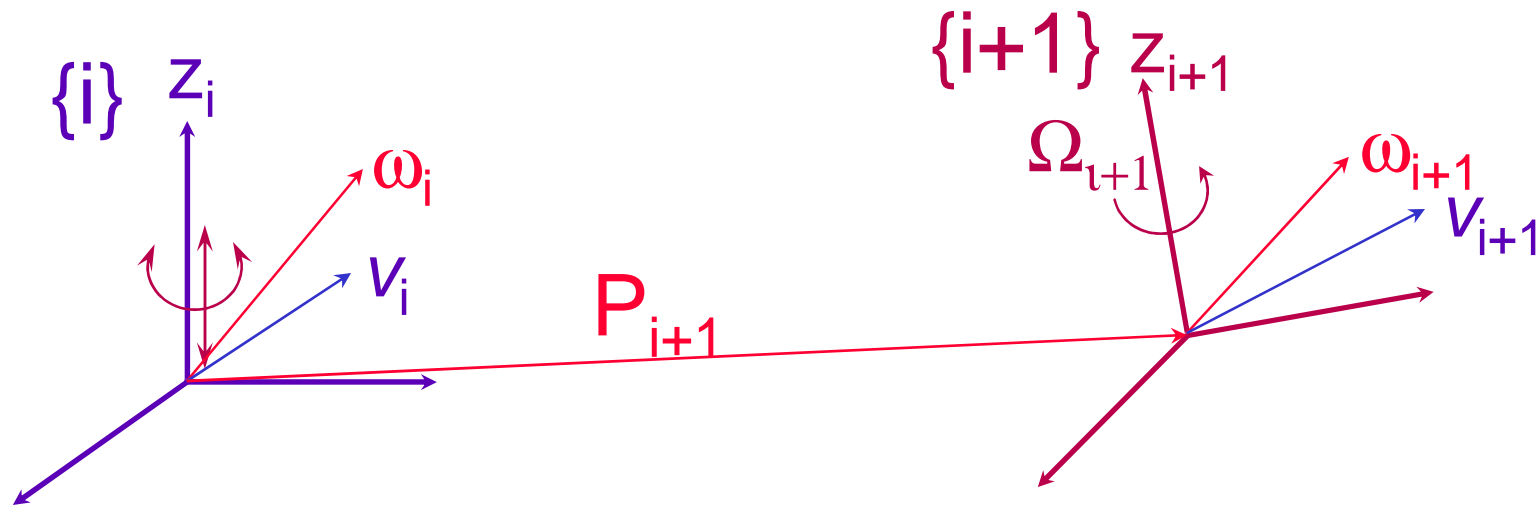

Linear

$$v_{i+1} = v_i + \omega_i \times P_{i+1} + \dot{d}_{i+1} \cdot Z_{i+1}$$

Angular

$$\omega_{i+1} = \omega_i + \Omega_{i+1}$$

$$\Omega_{i+1} = \dot{\theta}_{i+1} \cdot Z_{i+1}$$

Velocity propagation

Joint 1

v_1 and ω_1 in frame {1}

Joint $i+1$

$${}^{i+1}\omega_{i+1} = {}^{i+1}_i R \cdot {}^i\omega_i + \dot{\theta}_{i+1} \cdot {}^{i+1}Z_{i+1}$$

$${}^{i+1}v_{i+1} = {}^{i+1}_i R \cdot ({}^i v_i + {}^i\omega_i \times {}^i P_{i+1}) + \dot{d}_{i+1} \cdot {}^{i+1}Z_{i+1}$$

\Rightarrow ${}^n\omega_n$ and ${}^n v_n$

$$\begin{pmatrix} {}^0 v_n \\ {}^0 \omega_n \end{pmatrix} = \begin{pmatrix} {}^0_n R & \mathbf{0} \\ \mathbf{0} & {}^0_n R \end{pmatrix} \cdot \begin{pmatrix} {}^n v_n \\ {}^n \omega_n \end{pmatrix}$$

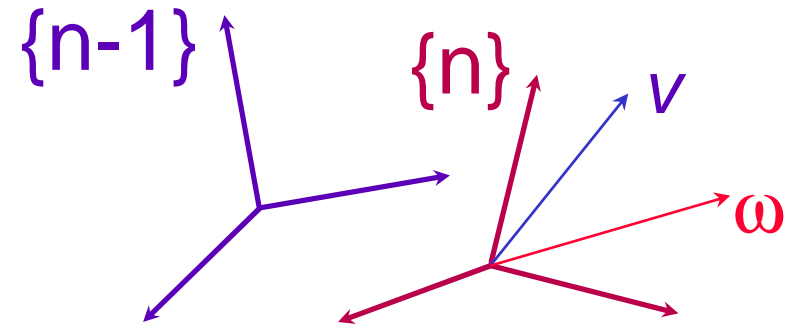

Example

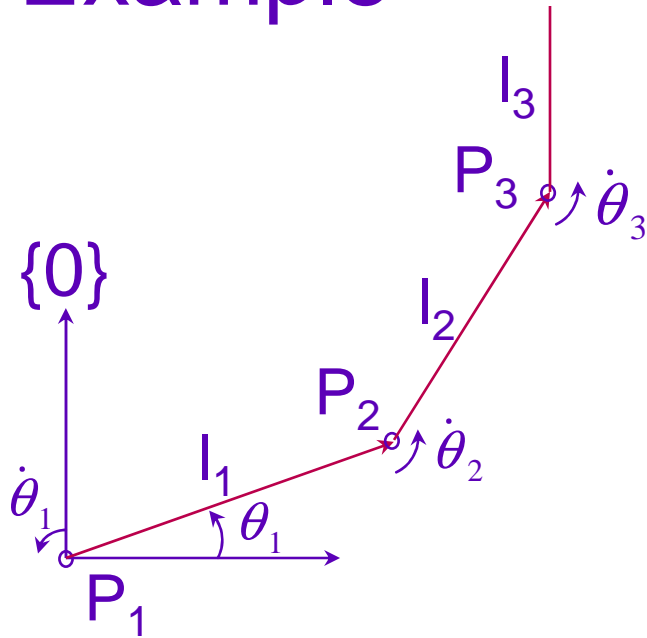

$$v_{i+1} = v_i + \omega_i \times P_{i+1}$$

- $v_{P_1} = 0$ ${}^0\omega_1 = \dot{\theta}_1 \cdot {}^0Z_1$
- $v_{P_2} = v_{P_1} + \omega_1 \times P_2$
- $v_{P_3} = v_{P_2} + \omega_2 \times P_3$

$${}^0v_{P_2} = 0 + \begin{bmatrix} 0 & -\dot{\theta}_1 & 0 \\ \dot{\theta}_1 & 0 & 0 \\ 0 & 0 & 0 \end{bmatrix} \cdot \begin{bmatrix} l_1 \cdot c_1 \\ l_1 \cdot s_1 \\ 0 \end{bmatrix} = \begin{bmatrix} -l_1 \cdot s_1 \\ l_1 \cdot c_1 \\ 0 \end{bmatrix} \cdot \dot{\theta}_1$$

$${}^0\mathbf{v}_{P_3} = {}^0\mathbf{v}_{P_2} + {}^0\boldsymbol{\omega}_2 \times {}^0\mathbf{P}_3$$

$$\begin{aligned}
 {}^0\mathbf{v}_{P_3} &= \begin{bmatrix} -l_1 \cdot s_1 \\ l_1 \cdot c_1 \\ 0 \end{bmatrix} \cdot \dot{\theta}_1 + \begin{bmatrix} 0 & -1 & 0 \\ 1 & 0 & 0 \\ 0 & 0 & 0 \end{bmatrix} \cdot (\dot{\theta}_1 + \dot{\theta}_2) \cdot {}^0\mathbf{P}_3 \\
 &= \begin{bmatrix} -l_1 \cdot s_1 \\ l_1 \cdot c_1 \\ 0 \end{bmatrix} \cdot \dot{\theta}_1 + \begin{bmatrix} -l_2 \cdot s_{12} \\ l_2 \cdot c_{12} \\ 0 \end{bmatrix} \cdot (\dot{\theta}_1 + \dot{\theta}_2) \quad \begin{bmatrix} l_2 \cdot c_{12} \\ l_2 \cdot s_{12} \\ 0 \end{bmatrix}
 \end{aligned}$$

$${}^0\boldsymbol{\omega}_3 = (\dot{\theta}_1 + \dot{\theta}_2 + \dot{\theta}_3) \cdot {}^0\mathbf{Z}_0$$

$${}^0v_{P_3} = \underbrace{\begin{bmatrix} -(l_1s_1 + l_2s_{12}) & -l_2s_{12} & 0 \\ l_1c_1 + l_2c_{12} & l_2c_{12} & 0 \\ 0 & 0 & 0 \end{bmatrix}}_{J_v} \cdot \begin{bmatrix} \dot{\theta}_1 \\ \dot{\theta}_2 \\ \dot{\theta}_3 \end{bmatrix}$$

$${}^0\omega_3 = \underbrace{\begin{bmatrix} 0 & 0 & 0 \\ 0 & 0 & 0 \\ 1 & 1 & 1 \end{bmatrix}}_{J_\omega} \cdot \begin{bmatrix} \dot{\theta}_1 \\ \dot{\theta}_2 \\ \dot{\theta}_3 \end{bmatrix}$$

$$\begin{pmatrix} v \\ \omega \end{pmatrix} = J \cdot \begin{pmatrix} \dot{\theta}_1 \\ \dot{\theta}_2 \\ \dot{\theta}_3 \end{pmatrix}$$